

# Air-operated diaphragm pumps

Type FDM



More than just pumps



# FLUX air-operated diaphragm pumps Type FDM – genuine allrounders



**FLUX air-operated diaphragm pumps are genuine allrounders for the safe reliable and careful (no shearing) transfer of thin to high viscosity products, even with solids in suspension, as well as abrasive, highly flammable or aerated liquids. Each pump model is available in different versions because of a great variety of possible material combinations of the wetted component parts.**

FLUX air-operated diaphragm pumps are powered by compressed air into the air inlet which in turn directs the air to a diaphragm which separates the air from the liquid section. The diaphragm is pressurized which forces the liquid out of the pump discharge. While this is happening the other diaphragm is de-pressurizing and sucking the liquid into the inlet the cycle is then repeated causing a constant flow through the pump unit via the ball valves. The flow is always in through the bottom of the pump inlet/suction and out of the top pump discharge.

It is a displacement pump. The diaphragm pump has the added advantage that the pump pressure is always limited by regulating the air inlet pressure.

The pumps in Aluminium, Cast Iron,  Stainless Steel and Acetal are ideal for use in hazardous areas.

## Special features:

FLUX air-operated diaphragm pumps have several benefits:

- Pressures up to 8 bar (20 bar on 3:1 ratio pump)
- Self priming, even from a dry start
- Variable delivery rates by adjusting air pressure to the pump
- No need of by-pass control
- No leakage due to absence of shaft seal
- Fully submersible
- Unbalanced air valve design eliminates stalling
- Ideal for use in hazardous areas
- No overloading; pump will stop if discharge closed
- Suitable for dry run operation

FLUX offers a complete range of air-operated diaphragm pump models with  $\frac{3}{8}$ ",  $\frac{1}{2}$ ", 1",  $1\frac{1}{2}$ ", 2" and 3" connections as well as a high pressure diaphragm pump.

In this brochure we present the most common versions. We also have other types/materials for special applications. Please contact our sales office.

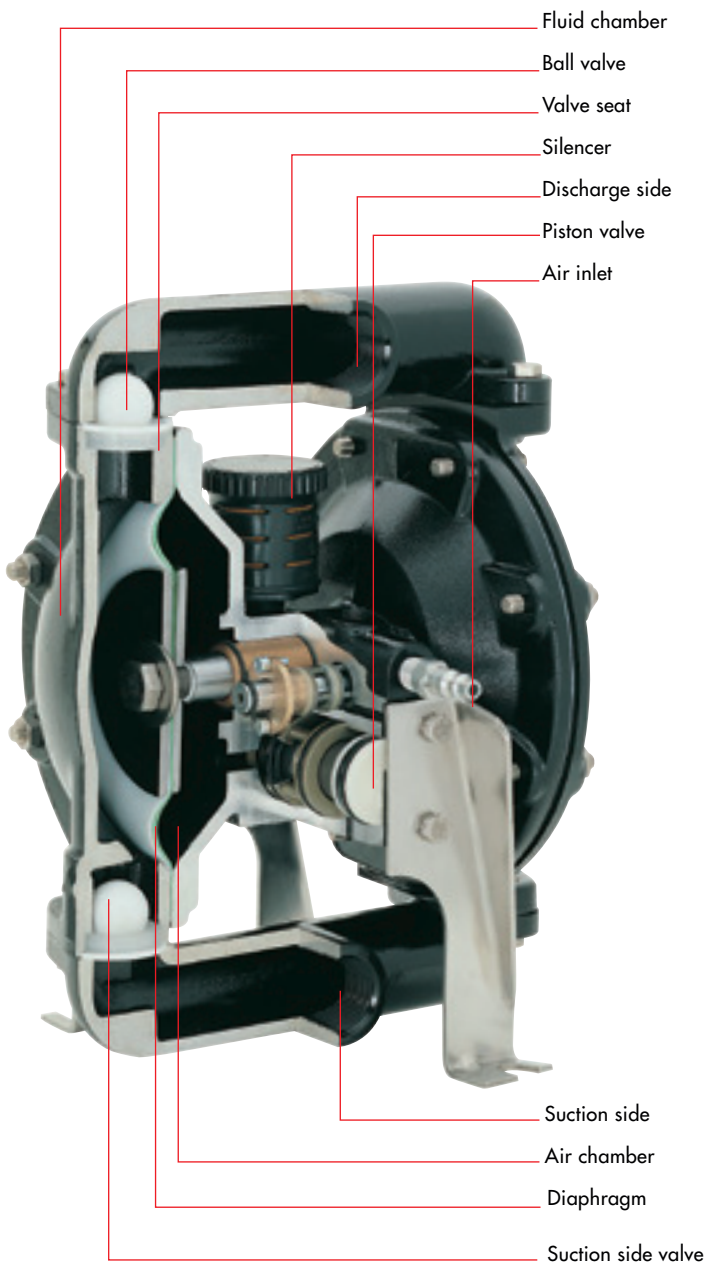
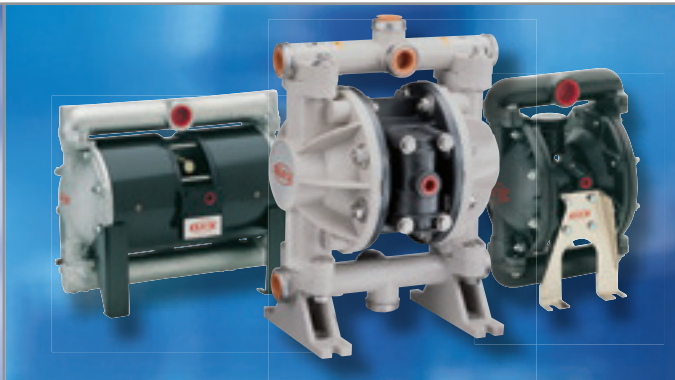

Materials of construction	<b>4</b>
Air-operated diaphragm pumps size 3/8", Type FDM 10	<b>5</b>
Air-operated diaphragm pumps size 1/2", Type FDM 12	<b>6 - 7</b>
Air-operated diaphragm pumps size 1", Type FDM 25	<b>8 - 9</b>
Air-operated diaphragm pumps size 1 1/2", Type FDM 40	<b>10 - 11</b>
Air-operated diaphragm pumps size 2", Type FDM 50	<b>12 - 13</b>
Air-operated diaphragm pumps size 3", Type FDM 80	<b>14</b>
High-pressure diaphragm pump size 1", Type FDMH 25	<b>15</b>
Accessories	<b>16 - 18</b>
The great range of FLUX pumps	<b>19</b>

## Non-metallic

### Polypropylene (PP)

suitable for corrosive liquids, acids and alkalis as well as neutral liquids.

Liquid examples: formic acid, ammonia, boracic acid, chromic acid (up to 10%), fertilizer, acetic acid, hydrofluoric acid (up to 70%), fruit acid, caustic potash, copper chloride, lactic acid, caustic soda, phosphoric acid, hydrochloric acid, sulphuric acid (up to 80%), distilled water.

### Polyvinylidene Fluoride (PVDF)

suitable for both, chemically aggressive and neutral liquids, together with low flammable liquids.

Liquid examples: hydrogen bromide, chromic acid, chloric acid, hydrofluoric acid, sodium hypochlorite, azotic acid (up to 75%), sulphuric acid and all under PP listed liquids (except caustic soda)

### Acetal (AC)

Polyoxymethylene, electrically conductive, suitable for solvents.

Liquid examples: acetate, acetone, chlorinated hydrocarbons, gasohol, cyclohexane, kerosine, methyl ethyl ketone, toluol, xylol.



## Metallic

### Aluminium Alloy AlMg5 (AL)

suitable for neutral and/or flammable liquids. Liquid examples: alcohol, gasohol, drilling fluid, diesel, glycol, fuel, hydraulic fluid, solvent, soap (fluid), wax (liquid), water.



### Stainless Steel 316 Ti (S)

suitable for highly flammable liquids as well as for neutral and non-flammable liquids. Liquid examples: acetone, alcohol, ammonia, benzene, flammable solvents, pyroxylin varnish, perchloroethylene, trichloroethylene, toluol, caustic potash, caustic soda, phosphoric acid (up to 60%), sulphuric acid (up to 7,5% and at 96%), fruit juice, milk, cooking oil and all under Aluminium listed products.



### Gray Cast Iron (GG)

suitable for solvents. Liquid examples: all under Aluminium listed liquids and alkaline liquids such as caustic soda and caustic potash, ammonia, slight saline solutions.



## Tips for the use of FLUX air-operated diaphragm pumps

### Operating temperature

Material	Temperature
Acetal (AC)	-10 up to +80 °C
Polypropylene (PP)	0 up to +65 °C
Polyvinylidene Fluoride (PVDF)	-10 up to +90 °C
Aluminium (AL)*	-10 up to +100 °C
Stainless Steel 316 Ti (S)*	-10 up to +100 °C
Gray Cast Iron (GG)*	-10 up to +100 °C
CR (Neoprene)	-10 up to +80 °C
EPDM	0 up to +80 °C
NBR (Perbunan)	0 up to +80 °C
PTFE (Teflon)	+5 up to +100 °C
Santopren (PP-EPDM-Copolymer)	0 up to +100 °C

\* Metals are suitable for higher temperatures. The application area of the pump is limited by the diaphragm/sealing compound.

### Diaphragm

By increasing hub frequency the expected durability of the diaphragms is reduced. The ideal operating conditions are between 40% and 60% of the maximum output.

### Viscosity

The output on the performance charts are based on water. Higher viscosity reduces the delivery rate depending on the pump type. Air-operated diaphragm pumps can pump high viscosity liquids up to the barrier of flowability. Important for the use and capacity of the pump are further arguments as adhesion, flowability, and molecular structure. Ask our sales engineers.

### Suction side

If the suction side increases 2 – 3 m, the delivery rate is reduced at 20%.



# FLUX air-operated diaphragm pump FDM 07 in non-metallic version, 1/4"



Dimensions [mm]

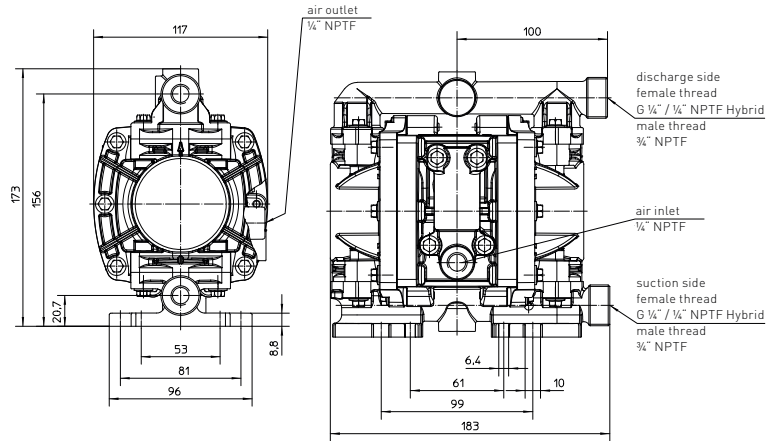

## Technical Data FDM 07

Delivery rate max.	20 l/min
Operating pressure max.	8,6 bar
Suction head max.*	9,5 m
Max. size of solids	1,6 mm
Connection suction side & discharge side	
Male thread (Hybrid)	1/4" NPTF, G 1/4"
Female thread	3/4" NPTF
Connection air	
Inlet	1/4" NPTF
Outlet	1/4" NPTF

\* depending on pump model, operating pressure and fluid

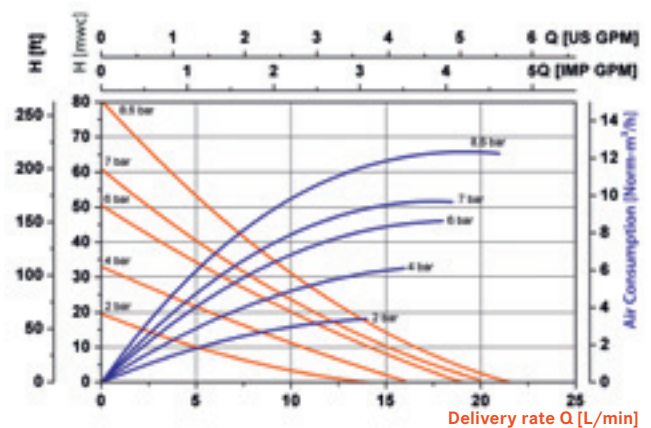

Values ± 10 % with water at 20 °C

Type	Pump housing	Diaphragm	Ball	Hub	Seal	Weight	Part No.
FDM 07 PP/AA	Polypropylene	Santoprene	Santoprene	PP	EPDM	1,3 kg	10-M07 40 010
FDM 07 PP/TT	Polypropylene	PTFE	PTFE	PP	PTFE	1,3 kg	10-M07 40 100
FDM 07 AC/TT	Acetal conductive	PTFE	PTFE	AC	PTFE	1,6 kg	10-M07 50 000



Air-motor body Polypropylene

Electrically conductive for use in hazardous areas according to ATEX-Directive 2014/34/EU.



# FLUX air-operated diaphragm pump FDM 10 in non-metallic version, 3/8"



Dimensions [mm]

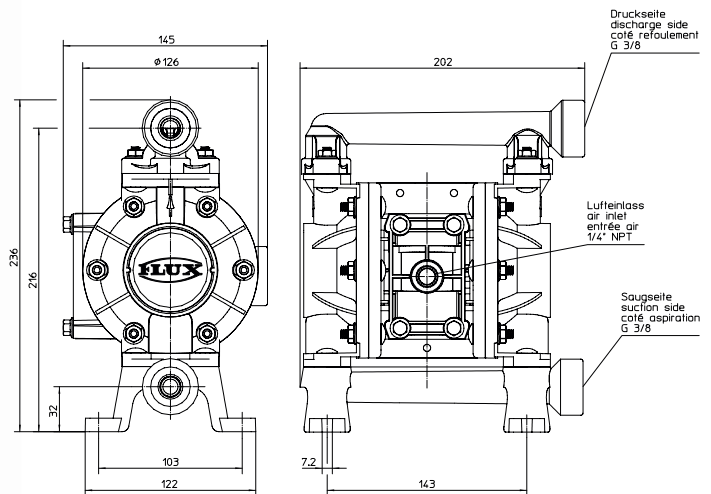

## Technical Data FDM 10

Delivery rate max.	40 l/min
Operating pressure max.	7 bar
Suction head max.*	7,6 m
Max. size of solids	1,6 mm
Connection pump	
Suction side	G 3/8
Discharge side	G 3/8
Connection air	
Inlet	1/4" NPT
Outlet**	1/2" NPT

\*Dry exhaust up to 2,6 m, \*\*with silencer

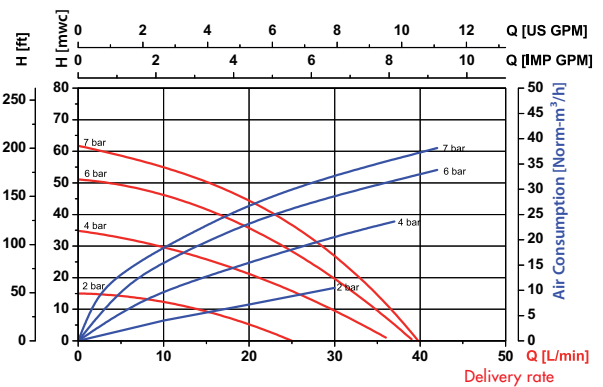

Values ± 10 % with water at 20 °C

Type	Pump housing	Diaphragm	Ball	Hub	Seal	Weight	Part No.
FDM 10 PP/AA	Polypropylene	Santopren	Santopren	PP	EPDM	1,6 kg	10-M10 40 010
FDM 10 PP/TT	Polypropylene	PTFE	PTFE	PP	PTFE	1,6 kg	10-M10 40 110
 FDM 10 AC/TT	Acetal conductive	PTFE	PTFE	Acetal	PTFE	1,9 kg	10-M10 50 110
FDM 10 PVDF/TT	Polyvinylidene Fluoride	PTFE	PTFE	PVDF	PTFE	2,1 kg	10-M10 60 110

Air-motor body Polypropylene

Electrically conductive for use in hazardous areas according to ATEX-Directive 2014/34/EU.



# FLUX air-operated diaphragm pump FDM 12 in non-metallic version, 1/2"



Dimensions [mm]

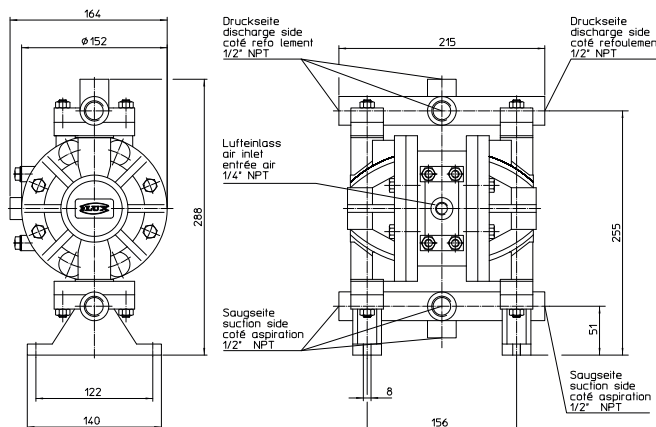

## Technical Data FDM 12

Delivery rate max.	50 l/min
Operating pressure max.	7 bar
Suction head max.*	7,6 m
Max. size of solids	2,4 mm
Connection pump	
Suction side	1/2" NPT
Discharge side	1/2" NPT
Connection air	
Inlet	1/4" NPT
Outlet**	1/4" NPT

\*Dry exhaust up to 3 m, \*\*with silencer

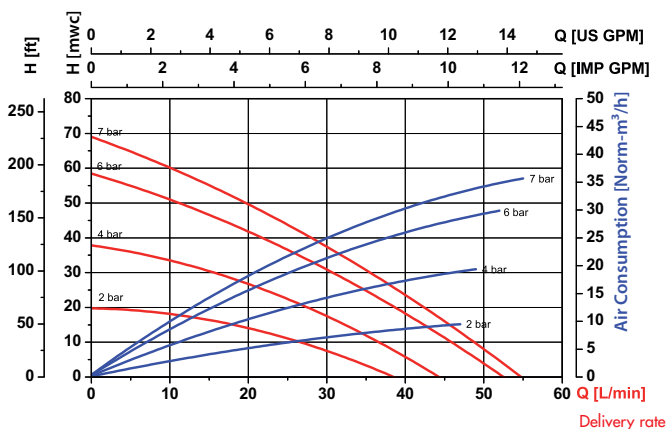

Values ± 10 % with water at 20 °C

Type	Pump housing	Diaphragm	Ball	Hub	Seal	Weight	Part No.
FDM 12 PP/CC	Polypropylene	CR	CR	PP	NBR	3,4 kg	10-M12 40 010
FDM 12 PP/AA	Polypropylene	Santopren	Santopren	PP	EPDM	3,4 kg	10-M12 40 210
FDM 12 PP/TT	Polypropylene	PTFE	PTFE	PP	PTFE	3,4 kg	10-M12 40 110
FDM 12 PVDF/TT	Polyvinylidene Fluoride	PTFE	PTFE	PVDF	PTFE	4,7 kg	10-M12 60 010
FDM 12 AC/TS	Acetal conductive	PTFE	Stainless Steel	Stainless Steel	FFKM	4,0 kg	10-M12 50 010



Air-motor body Polypropylene

Electrically conductive for use in hazardous areas according to ATEX-Directive 2014/34/EU.



# FLUX air-operated diaphragm pump FDM 12 in metallic version, 1/2"

Electrically conductive for use in hazardous areas according to ATEX-Directive 2014/34/EU.



FDM 12 AL



FDM 12 S

Dimensional drawing on request.

## Technical Data FDM 12

Delivery rate max.	55 l/min
Operating pressure max.	7 bar
Suction head max.*	7,6 m
Max. size of solids	2,4 mm
Connection pump	
Suction side	1/2" NPT
Discharge side	1/2" NPT
Connection air	
Inlet	1/4" NPT
Outlet**	1/4" NPT

\*Dry exhaust up to 3 m, \*\*with silencer

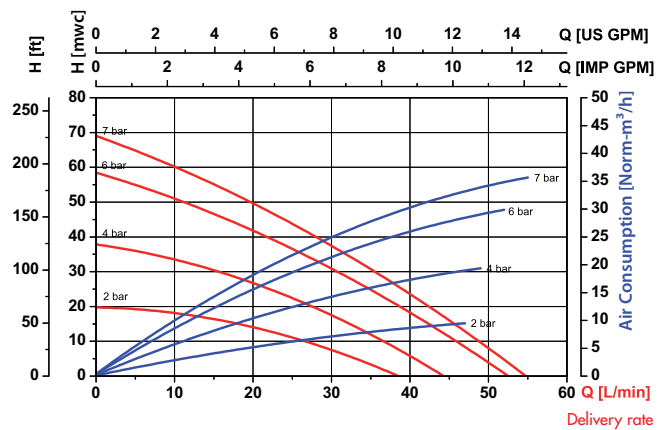

Values ± 10 % with water at 20 °C

Type	Pump housing	Diaphragm	Ball	Hub	Seal	Weight	Part No.
FDM 12 AL/TT	Aluminium	PTFE	PTFE	AL	PTFE	3,8 kg	10-M12 10 100
FDM 12 AL/NN	Aluminium	NBR	NBR	AL	NBR	3,8 kg	10-M12 10 200
FDM 12 S/TT	Stainless Steel	PTFE	PTFE	Stainless Steel	PTFE	6,6 kg	10-M12 20 000

Air-motor body Polypropylene



# FLUX air-operated diaphragm pump FDM 25 in non-metallic version, 1"



Dimensions [mm]

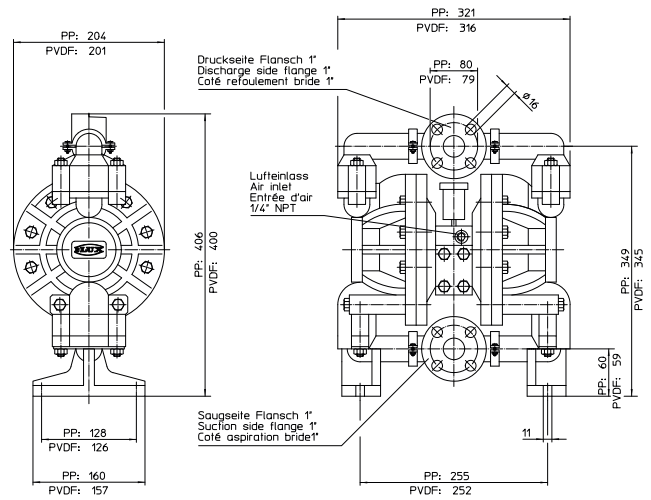

## Technical Data FDM 25

Delivery rate max.	178 l/min
Operating pressure max.	8 bar
Suction head*	7,6 m
Max. size of solids	3,2 mm
Connection pump	
Suction side***	Flange 1"
Discharge side***	Flange 1"
Connection air	
Inlet	1/4" NPT
Outlet**	3/8" NPT

\*Dry exhaust up to 4,5 m, \*\*with silencer  
\*\*\*connecting dimensions for DN 25, DN 6 appropriate

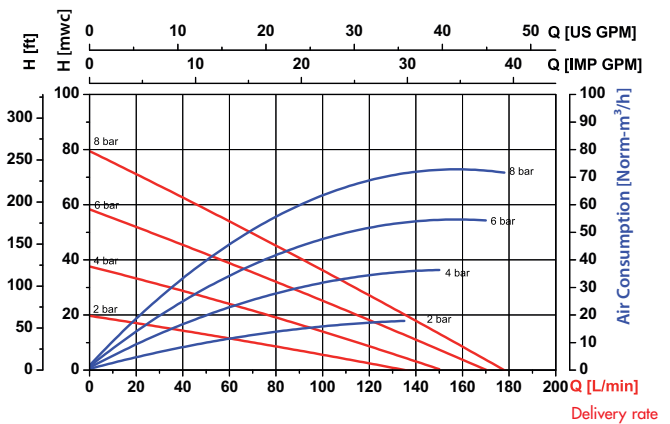

Values ± 10 % with water at 20 °C

Typ	Pump housing	Diaphragm	Ball	Hub	Seal	Weight	Part No.
FDM 25 PP/AA	Polypropylene	Santopren	Santopren	PP	EPDM	9,2 kg	10-M25 40 010
FDM 25 PP/TT	Polypropylene	PTFE	PTFE	PP	PTFE	9,2 kg	10-M25 40 100
FDM 25 PVDF/TT	Polyvinylidene Fluoride	PTFE	PTFE	PVDF	PTFE	13,0 kg	10-M25 60 000

Air-motor body Aluminium

# FLUX air-operated diaphragm pump FDM 25 in metallic version, 1"

Electrically conductive for use in hazardous areas according to ATEX-Directive 2014/34/EU.



Dimensions [mm]

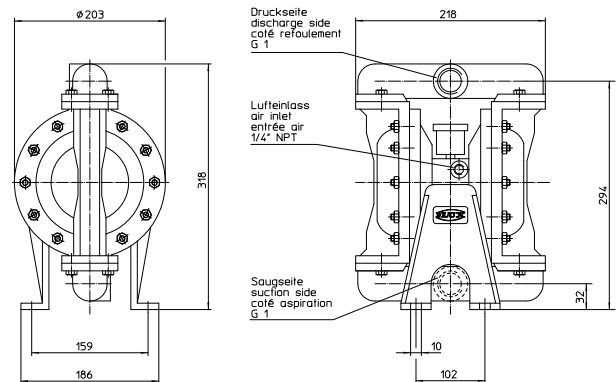

## Technical Data FDM 25

Delivery rate max.	133 l/min
Operating pressure max.	8 bar
Suction head max.*	7,6 m
Max. size of solids	3,2 mm
Connection pump	
Suction side	G 1
Discharge side	G 1
Connection air	
Inlet	1/4" NPT
Outlet**	3/8" NPT

\*Dry exhaust up to 6,0 m, \*\*with silencer

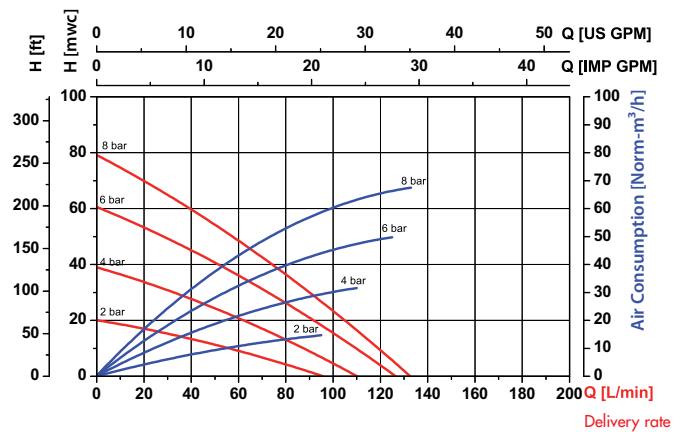

Values  $\pm 10\%$  with water at 20 °C

Type	Pump housing	Diaphragm	Ball	Hub	Seal	Weight	Part No.
FDM 25 AL/NN	Aluminium	NBR	NBR	AL	NBR	8,6 kg	10-M25 10 000
FDM 25 AL/TT	Aluminium	PTFE	PTFE	AL	PTFE	8,6 kg	10-M25 10 100
FDM 25 S/TT	Stainless Steel	PTFE	PTFE	Stainless Steel	PTFE	14,0 kg	10-M25 20 100

Air-motor body Aluminium

Electrically conductive for use in hazardous areas according to ATEX-Directive 2014/34/EU.



Illustration similar

Dimensional drawing upon request.

### Technical Data FDMH 25

Delivery rate max.	85 l/min
Delivery pressure max.	20 bar
Operating pressure max.	7 bar
Ratio	3 : 1
Max. size of solids	3,2 mm
Connection pump	
Suction side	G 1
Discharge side	G 1
Connection air	
Inlet	3/8" NPT
Outlet*	3/8" NPT

\*With silencer

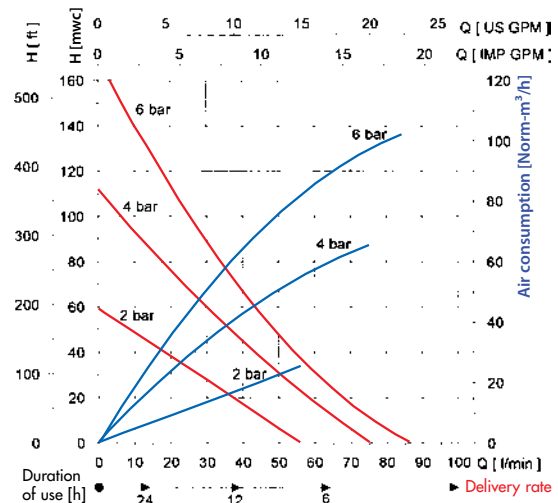

Values ± 10 % with water at 20 °C

Type	Pump housing	Diaphragm	Ball	Hub	Seal	Weight	Part No.
FDMH 25 S/TS	Stainless Steel	PTFE	Stainless Steel	Stainless Steel	PTFE	43,0 kg	10-M25 20 200

Air-motor body Aluminium

### Application examples:

- Colour agitation
- Conveyance of fluids with a high viscosity through pipings with thereby resulting high pressure
- Filter presses
- High viscosity or pasty substances

# FLUX air-operated diaphragm pump FDM 40 in non-metallic version, 1½"



Dimensions [mm]

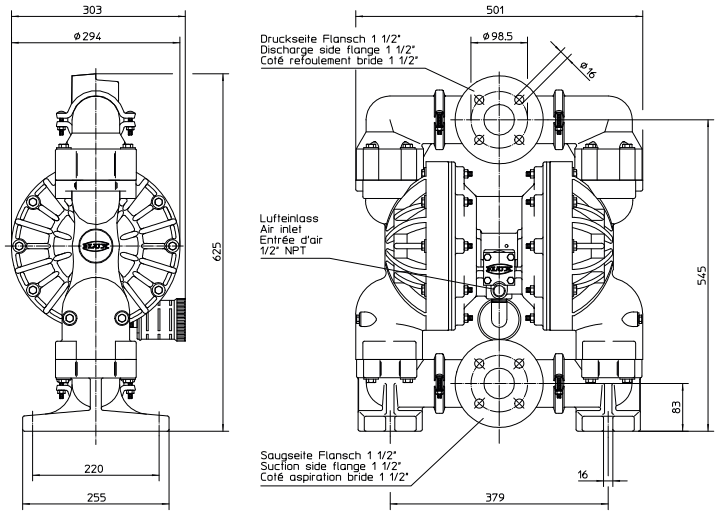

## Technical Data FDM 40

Delivery rate max.	380 l/min
Operating pressure max.	8 bar
Suction head max.*	7,6 m
Max. size of solids	6,4 mm
Connection pump	
Suction side***	Flange 1½"
Discharge side***	Flange 1½"
Connection air	
Inlet	½" NPT
Outlet**	¾" NPT

\*Dry exhaust up to 4,2 m, \*\*with silencer  
\*\*\*connecting dimensions for DN 25, DN 6 appropriate

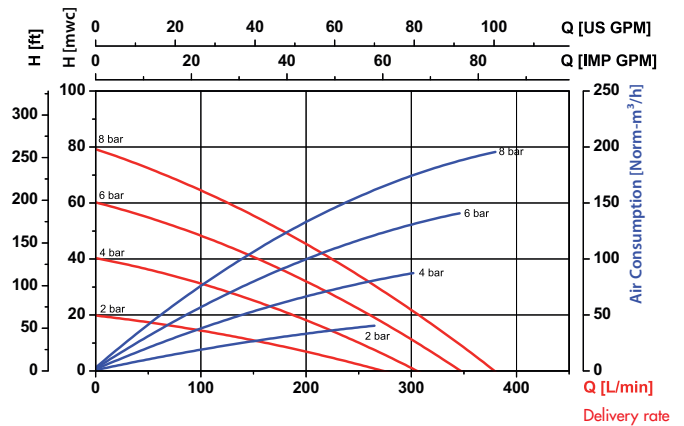

Values ± 10 % with water at 20 °C

Type	Pump housing	Diaphragm	Ball	Hub	Seal	Weight	Part No.
FDM 40 PP/AA	Polypropylene	Santopren	Santopren	PP	EPDM	28,1 kg	10-M40 40 010
FDM 40 PP/TT	Polypropylene	PTFE	PTFE	PP	PTFE	28,1 kg	10-M40 40 100
FDM 40 PVDF/TT	Polyvinylidene Fluoride	PTFE	PTFE	PVDF	PTFE	41,7 kg	10-M40 60 000

Air-motor body Aluminium



# FLUX air-operated diaphragm pump FDM 40 in metallic version, 1½"



Electrically conductive for use in hazardous areas according to ATEX-Directive 2014/34/EU.



Illustration similar

Dimensional drawing upon request.

## Technical Data FDM 40

Delivery rate max.	340 l/min
Operating pressure max.	8 bar
Suction head max.*	7,6 m
Max. size of solids	6,4 mm
Connection pump	
Suction side	G 1½
Discharge side	G 1½
Connection air	
Inlet	½" NPT
Outlet**	¾" NPT

\*Dry exhaust up to 6,0 m, \*\*with silencer

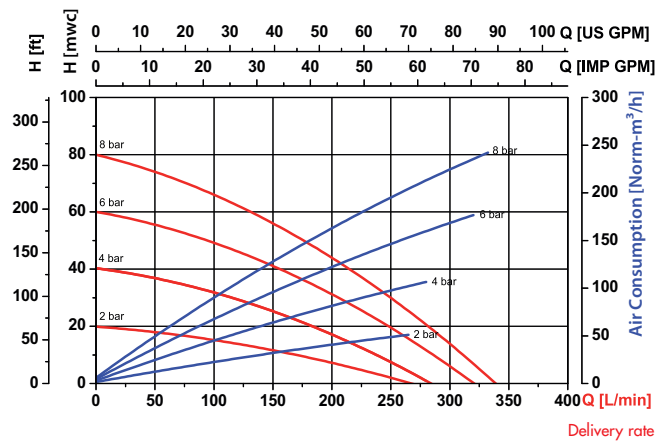

Values ± 10 % with water at 20 °C

Type	Pump housing	Diaphragm	Ball	Hub	Seal	Weight	Part No.
FDM 40 AL/NN	Aluminium	NBR	NBR	AL	NBR	23,4 kg	10-M40 10 000
FDM 40 AL/TT	Aluminium	PTFE	PTFE	AL	PTFE	23,4 kg	10-M40 10 100
FDM 40 S/TT	Stainless Steel	PTFE	PTFE	Stainless Steel	PTFE	38,3 kg	10-M40 20 100
FDM 40 GG/NN	Gray Cast Iron	NBR	NBR	PP	NBR	36,1 kg	10-M40 30 000

Air-motor body Aluminium

# FLUX air-operated diaphragm pump FDM 50 in non-metallic version, 2"



Dimensions [mm]

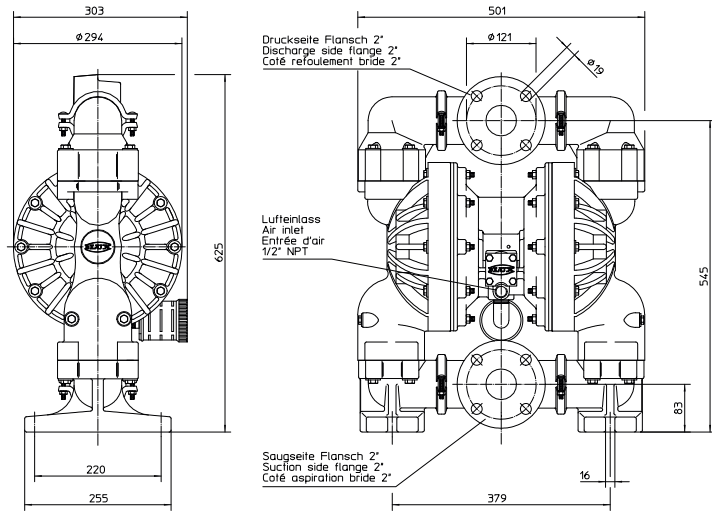

## Technical Data FDM 50

Delivery rate max.	540 l/min
Operating pressure max.	8 bar
Suction head max.*	7,6 m
Max. size of solids	6,4 mm
Connection pump	
Suction side***	Flange 2"
Discharge side***	Flange 2"
Connection air	
Inlet	1/2" NPT
Outlet**	3/4" NPT

\*Dry exhaust up to 4,0 m, \*\*with silencer  
\*\*\*connecting dimensions for DN 25, DN 6 appropriate

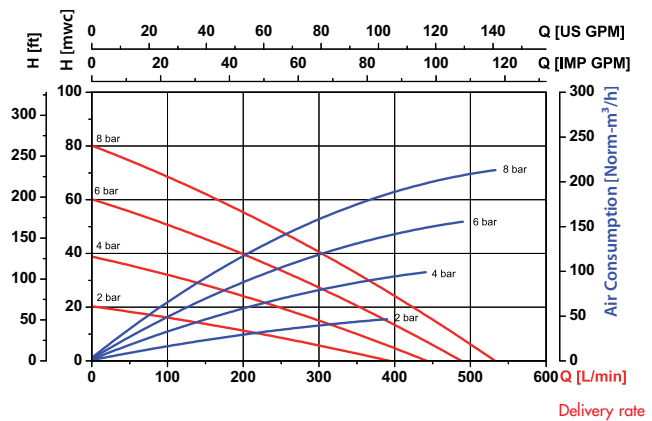

Type	Pump housing	Diaphragm	Ball	Hub	Seal	Weight	Part No.
FDM 50 PP/AA	Polypropylene	Santopren	Santopren	PP	EPDM	28,1 kg	10-M50 40 010
FDM 50 PP/TT	Polypropylene	PTFE	PTFE	PP	PTFE	28,1 kg	10-M50 40 100
FDM 50 PVDF/TT	Polyvinylidene Fluoride	PTFE	PTFE	PVDF	PTFE	41,7 kg	10-M50 60 000

Air-motor body Aluminium

# FLUX air-operated diaphragm pump FDM 50 in metallic version, 2"



Electrically conductive for use in hazardous areas according to ATEX-Directive 2014/34/EU.



Illustration similar

Dimensional drawing upon request.

## Technical Data FDM 50

Delivery rate max.	650 l/min
Operating pressure max.	8 bar
Suction head max.*	7,6 m
Max. size of solids	6,4 mm
Connection pump	
Suction side	G 2
Discharge side	G 2
Connection air	
Inlet	3/4" NPT
Outlet**	1 1/2" NPT

\*Dry exhaust up to 4,2 m, \*\*with silencer

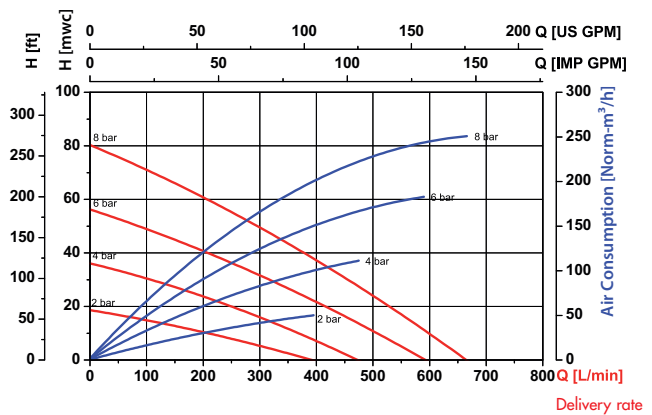

Values ± 10 % with water at 20 °C

Type	Pump housing	Diaphragm	Ball	Hub	Seal	Weight	Part No.
FDM 50 AL/NN	Aluminium	NBR	NBR	NBR	-	41,5 kg	10-M50 10 200
FDM 50 AL/TT	Aluminium	PTFE	PTFE	PVDF	PTFE	41,5 kg	10-M50 10 300
FDM 50 S/TT	Stainless Steel	PTFE	PTFE	PVDF	PTFE	68,0 kg	10-M50 20 300
FDM 50 GG/TT	Gray Cast Iron	PTFE	PTFE	PVDF	PTFE	66,9 kg	10-M50 30 300

Air-motor body Aluminium

FLUX air-operated diaphragm pump FDM 50 with flap valve on request.

# FLUX air-operated diaphragm pump FDM 80 in metallic version, 3"

Electrically conductive for use in hazardous areas according to ATEX-Directive 2014/34/EU.



Illustration similar

Dimensional drawing upon request.

## Technical Data FDM 80

Delivery rate max.	1.040 l/min
Operating pressure max.	8 bar
Suction head max.*	7,3 m
Max. size of solids	9,5 mm
Connection pump	
Suction side	G 3
Discharge side	G 3
Connection air	
Inlet	¾" NPT
Outlet**	1½" NPT

\*Dry exhaust up to 4,2 m, \*\*with silencer

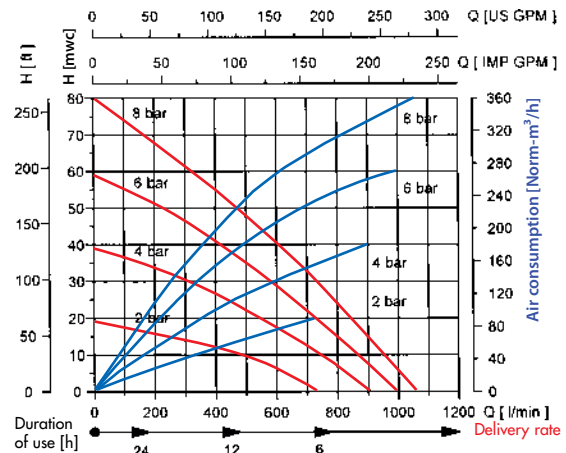

Values ± 10 % with water at 20 °C

Type	Pump housing	Diaphragm	Ball	Hub	Seal	Weight	Part No.
FDM 80 AL/NN	Aluminium	NBR	NBR	NBR	-	58,8 kg	10-M80 10 000
FDM 80 AL/TT	Aluminium	PTFE	PTFE	Stainless Steel	PTFE	58,8 kg	10-M80 10 100
FDM 80 S/TT	Stainless Steel	PTFE	PTFE	Stainless Steel	PTFE	103,8 kg	10-M80 20 100
FDM 80 GG/TT	Gray Cast Iron	PTFE	PTFE	Stainless Steel	PTFE	100,3 kg	10-M80 30 100

Air-motor body Aluminium



## Hose nipples



Pump	Material	Description	Use	Part No.
FDM 10	PVC	DN 15 – G 3/8" A	For direct adaption onto the pump	10-959 05 232
	MS	DN 13 – G 3/8" A		10-959 05 231
FDM 12	PP	DN 13 – G 1/2 A	For direct adaption onto the pump	10-959 05 183
	MS	DN 13 – G 1/2 A		10-959 05 017
	316 Ti	DN 13 – G 1/2 A		10-959 05 249
FDM 25	MS	DN 19 – G 1 A	For direct adaption onto the pump	10-959 05 161
	MS	DN 25 – G 1 A		10-959 05 052
	316 Ti	DN 19 – G 1 A		10-959 05 191
	316 Ti	DN 25 – G 1 A		10-959 05 190
	PP	DN 25 – G 1 A		10-959 05 192

## Reduction nipples



FDM 10	PP	G 1 A – G 3/8 A	Connection between pump and hose connection	10-959 06 159
	PVDF	G 1 A – G 3/8 A		10-959 06 169
FDM 12	PP	G 1 1/4 A – 1/2 NPT	Connection between pump and hose connection	10-959 06 078
	PVDF	G 1 1/4 A – 1/2 NPT		10-959 06 077
	316 Ti	G 1 1/4 A – 1/2 NPT		10-959 06 079

## Reduction nipples



FDM 25	MS	G 1 A – G 1 1/4 A (short, l = 45 mm for pressure socket)	Connection between pump and hose connection	10-959 06 080
	MS	G 1 A – G 1 1/4 A (long, l = 100 mm for inlet side)		10-959 06 082
	316 Ti	G 1 A – G 1 1/4 A (short, l = 45 mm for pressure socket)	Connection between pump and hose connection	10-959 06 081
	316 Ti	G 1 A – G 1 1/4 A (long, l = 100 mm for inlet side)		10-959 06 083

## Double nipples



FDM 40	MS	G 1 1/2 A – G 1 1/2 A	Connection between pump and hose connection	10-001 18 051
	316 Ti	G 1 1/2 A – G 1 1/2 A		10-001 18 003
FDM 50	MS	G 2 A – G 2 A	Connection between pump and hose connection	10-959 06 098
	316 Ti	G 2 A – G 2 A		10-959 06 099

## Hose connections

Hose plug with cap nut and seal

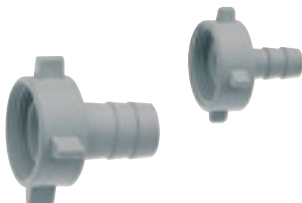

FDM 10	PP	DN 13	Only in conjunction with reduction nipple 10-959 06 159	10-959 04 073
	PP	DN 19		10-959 04 074
	PVDF	DN 13	Only in conjunction with reduction nipple 10-959 06 169	10-959 04 177
	PVDF	DN 19		10-959 04 178
FDM 12	PP	DN 13	Only in conjunction with reduction nipple 10-959 06 078	10-959 04 081
	PP	DN 19		10-959 04 053
	PP	DN 25		10-959 04 052
	PP	DN 32		10-959 04 054
FDM 12	PVDF	DN 13	Only in conjunction with reduction nipple 10-959 06 077	10-959 04 082
	PVDF	DN 19		10-959 04 101
	PVDF	DN 25		10-959 04 102
	PVDF	DN 32		10-959 04 103
FDM 12	316 Ti	DN 19	Only in conjunction with reduction nipple 10-959 06 079	10-959 04 116
	316 Ti	DN 25		10-959 04 117
	316 Ti	DN 32		10-959 04 118

# Accessories

## Hose connections

Hose plug with cap nut G 1¼ and seal

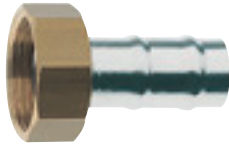

Pump	Material	Description	Use	Part No.
FDM 25	PP	DN 13	Only in conjunction with flange (PP)	10-959 04 081
	PP	DN 19		10-959 04 053
	PP	DN 25		10-959 04 052
	PP	DN 32		10-959 04 054
FDM 25	PVDF	DN 13	Only in conjunction with flange (PVDF)	10-959 04 082
	PVDF	DN 19		10-959 04 101
	PVDF	DN 25		10-959 04 102
	PVDF	DN 32		10-959 04 103
FDM 25	AL	DN 25	Only in conjunction with reduction nipples (MS)	10-959 04 119
	AL	DN 32		10-959 04 120
FDM 25	316 Ti	DN 19	Only in conjunction with reduction nipple (316 Ti)	10-959 04 116
	316 Ti	DN 25		10-959 04 117
	316 Ti	DN 32		10-959 04 118

## Hose connections

Hose plug with cap nut G 1½ and seal

FDM 40	AL	DN 25	Only in conjunction with double nipples	10-959 04 005
	AL	DN 32		10-959 04 006
	AL	DN 38		10-959 04 001
FDM 40	316 Ti	DN 25	Only in conjunction with double nipples	10-959 04 002
	316 Ti	DN 32		10-959 04 003
	316 Ti	DN 38		10-959 04 004

## Hose connections

Hose plug with cap nut G 2 and seal



FDM 50	PP	DN 32	Only in conjunction with flange (PP)	10-959 04 010
	PP	DN 38		10-959 04 011
	PP	DN 50		10-959 04 012
FDM 50	PVDF	DN 32	Only in conjunction with flange (PVDF)	10-959 04 084
	PVDF	DN 38		10-959 04 085
	PVDF	DN 50		10-959 04 086
FDM 50	AL	DN 50		10-959 04 008
FDM 50	316 Ti	DN 32	Only in conjunction with double nipples	10-959 04 059
	316 Ti	DN 38		10-959 04 060
	316 Ti	DN 50		10-959 04 009

**Flange \***  
complete with seal and 4 screws



\* dimension according to ASA 150 lbs (standard of pump flanges)

FDM 25	PP	with G 1¼ A	Connection between pump and hose connection	10-947 14 059
	PVDF	with G 1¼ A		10-947 14 060
FDM 40	PP	with G 2 A	Connection between pump and hose connection	10-947 14 061
	PVDF	with G 2 A		10-947 14 062
FDM 50	PP	with G 2 A	Connection between pump and hose connection	10-947 14 063
	PVDF	with G 2 A		10-947 14 064

## Earth cable complete with pocket clip

electrically conductive connection between pump and drum, for earthing and equipotential bonding



Length	Use	Part No.
2 m	FDM 10 – FDM 80	10-931 90 008
3 m	FDM 10 – FDM 80	10-931 90 013
2 m	FDM 10 – FDM 80 (amplified version)	10-931 90 015
2 m	FDM 10 – FDM 80 (with clips in Stainless Steel)	10-931 90 018

## filter-regulator-lubricator unit



Pump	Connection	Part No.
FDM 07 - FDM 25	G 1/4" female	10-001 10 111
FDM 07 - FDM 25, explosion-proof	G 1/4" female	10-001 10 114
FDM 40 - FDM 80	G 1/2" female	10-001 10 110
FDM 40 - FDM 80, explosion-proof	G 1/2" female	10-001 10 117

## Suction tube for FDM 10, FDM 12 and FDM 25

Stainless Steel,  
G 3/8" BSPPF at Ø 18 mm  
thread connector below,  
G 3/4" BSPPF at Ø 28 mm



Construction	Lengths	Part No.
above with hoze nozzle DN 25	700 mm	10-959 18 000
	1.000 mm	10-959 18 001
upper thread connector 1" BSPPM	700 mm	10-959 18 002
	1.000 mm	10-959 18 003
upper thread connector 1 1/4" BSPPM	700 mm	10-959 18 004
	1.000 mm	10-959 18 005

## Suction tube for FDM 10, FDM 12 and FDM 25

Polypropylene,  
thread connector below,  
1/2" BSPPM at Ø 20 mm,  
3/4" BSPPM at Ø 25 mm

Other suction tubes on request

Construction	Lengths	Part No.
above with hoze nozzle DN 25	700 mm	10-959 18 008
	1.000 mm	10-959 18 009
upper thread connector 1" BSPPM	700 mm	10-959 18 010
	1.000 mm	10-959 18 011
upper thread connector 1 1/4" BSPPM	700 mm	10-959 18 012
	1.000 mm	10-959 18 013

## Suction strainer for suction tubes



Material	Description	Use	Part No.
316 Ti	Ø 32 mm, G 3/4 A	for suction tube S Ø 28 mm	10-001 10 325
PP	Ø 34 mm, G 3/4	for suction tube PP Ø 25 mm	10-001 10 324

## Air connection (double nipple fixing)



Pump	Description	Use	Part No.
FDM 10 FDM 12 FDM 25	Brass, straight, 1/4" NPT – 1/4" BSPPM	Connection between pump and pressure regulator/ filter regulator	10-959 06 088
FDM 40 FDM 50 PP/PVDF	Brass, straight, 1/2" NPT – 1/2" BSPPM		10-959 06 086
FDM 50 AL/S/GG FDM 80 AL/S/GG	Brass with 90° bend 3/4" NPT – 1/2" BSPPM		10-959 06 138

## Hose couplings



Pump	Description	Part No.
FDM 10 FDM 12 FDM 25	Self locking hose coupling MS consisting of nipple and coupling DN 10 – G 1/4 A	10-959 13 108
FDM 40/50/80	DN 13 – G 1/2 A	10-959 13 109

## Compressed air hose



Nominal width	Description/Use	Part No.
DN 10	DN 10, electrically conductive, blue, outer-Ø 17 mm	10-001 10 098
DN 13	PVC, outer-Ø 20 mm	10-001 10 008

## Hose clips



Description/Use	Clamping range	Part No.
Hose clips (screw version), steel (chrome-plated)	10 – 17 mm	10-959 13 120
Hose clips (screw version), Stainless Steel	16 – 27 mm	10-959 13 165



More than just pumps

Today the FLUX name is recognised around the globe as the trademark for top standards in pump technology. Everything started with the invention of the electric drum pump in 1950. Nowadays FLUX has an extensive range of products each of which can be customized. FLUX pumps are used for example in the chemical and pharmaceutical industries; in machinery and plant engineering as well as companies in electroplating, wastewater treatment and the food sector.

Whether single-product or system solution – FLUX quality is synonymous with a long service life, excellent economy and maximum safety.

In addition to the excellent product quality FLUX customers appreciate the superb level of expertise our staff has to offer as well as their genuine customer focus.

These days FLUX-GERÄTE GMBH supplies pumps to almost 100 countries around the globe.