

Valvcon™ 115VAC and 230VAC electric actuator

Series V

General

Valmet is a leading designer and provider of compact, reliable, electronically controlled electric actuators for valves and dampers. We offer a complete line of Valvcon™ electric actuators for accurate positioning of dampers and valves in the aerospace, automotive, consumer services, discrete manufacturing, energy, environmental, oil/pipeline, petrochemical, power/utilities, process, recreation, transportation, and water/wastewater industries.

We have developed and introduced the industry's most innovative electric actuator features, including simple "set and go" calibration, intelligent processor-based digital electronics, "plug-in" accessory boards, back-up power, as well as electric actuators designed for remote control, solar-powered applications and two-wire network applications.

Specifications

The quarter-turn electric actuator complies with Part 15, Class A of the FCC regulations for emissions and conducted radiation for industrial devices. meets NEMA standards for use in weathertight or weathertight and hazardous locations. The actuator is a single, complete unit composed of a compact cast aluminum housing, motor, gearing, limit switches controlled by metal cams for end of travel control, a mechanical position indicator, and a wrench-operated manual override shaft. Actuator mounting flanges comply with ISO 5211 standards incorporating a female drive for direct output coupling. The actuator is capable of operating in ambient environments of -40°F to 150°F / -40°C to 66°C.

Features and benefits

Motor

The motor is capable of running continuously at full torque for up to 15 minutes at ambient temperatures at or below 104°F / 40°C. Subsequently, the motor is capable of 75% duty cycle. Motors are split phase, capacitor driven with an auto reset thermal sensor, and provide high starting torque and are totally enclosed within the actuator's housing cover.



Lubrication

All rotating power train components are coated with a multi-purpose grease. Lubricants are suitable for ambient conditions of -40°F to 150°F / -40°C to 66°C.

Gearing

The powertrain is comprised of hardened steel, machine cut spur gears. Non-metallic, aluminum, cast or stamped gearing is not used.

Manual operation

A wrench-operated override shaft is provided for manual operation. As an option, a metallic hand wheel may also be provided. The override device is engaged through a declutching mechanism, which separates the final output drive from the motor output.

Limit switches

Actuators have two standard end of travel switches, single pole double throw, rated at 11 amps at 250 VAC. The limit switches are activated by metal cams mounted on the actuator drive shaft. At the end of travel, the power is routed through the limit switches to a terminal strip location for pilot or position indication applications. The limit indicator outputs are fuse protected with auto-resetting polyfuses, with a working limit of 0.25 amps, to protect the limit switches and internal circuitry from possible overloads originating outside of the actuator. To simplify maintenance, these polyfuses are permanent and do not need to be replaced. They reset automatically, shortly after the overload condition is corrected - in approximately 3 minutes. Two additional limit switches are included in the actuator, adjustable to operate at any position, as required by the process application.

Open/close operation

Open/Close actuators are controlled via two, powered, maintained contacts, one for driving in the clockwise direction, and one for driving in the counter-clockwise direction. Power may be removed mid-stroke to position the valve. The AC input power is fuse protected on both AC Hot and AC Common. The fuses will never blow in normal operation - they are conservatively rated and soldered in place for high reliability.

Automatic cycling / cycle-rate regulation operation

The Speed Control feature solves the problem of the valve opening too quickly in fluid and steam applications where the resulting “hammer” or “shock” is eliminated. Both cycles, (CW and CCW) can be extended independently anywhere from the normal speed down to 1/200th the normal speed.

The Timer feature provides automatic cycling in On/Off applications where the actuation cycle can be scheduled anywhere from once every minute to once every 24 hours.

The V-series from Valmet

With the innovative Valvcon™ V-Series, Valmet pioneered the concept of plug-in, modular electronics in valve automation. This concept redefined and simplified the entire valve actuation process-upgrades and modifications can now be done in the field, in a matter of minutes, with no hard wiring, soldering or factory returns.

For years, the V-Series has set the standard for high quality, rugged and reliable electric actuators. Valmet uses its proven technology to vastly simplify actuator set-up and calibration and to enhance actuator performance. V-Series electric actuators are designed to offer highly efficient operation in a compact package. Ideally suited for most quarter-turn valves and dampers, they are designed for a wide range of service, from on-off duty, to automatic cycling applications.

Flexible, reliable actuation

The Valmet reputation for success is also built on the ability to meet the needs of its customers with high quality, reliable, “leading edge” actuator technology, products and services. We strive to anticipate and exceed your application needs. Engineered with a modular approach, Valvcon™ actuation systems allow you to modify or upgrade actuators in the field - giving you the flexibility to actuate new valves or to retrofit existing valves with amazing ease.

Extended duty cycle for continuous cycling

Valmet conservatively rates its AC motors at 75% duty cycle. Motors can operate continuously at full rated torque for up to 15 minutes without pausing. After running continuously for 15 minutes, motors need to rest for only 1/3 of the cycle time between each cycle. That is, if the cycle time is 30 seconds, they must rest for 10 seconds between each cycle. In constantly modulating applications, all Valvcon™ V-Series actuators can handle up to 30 starts per minute.

Breakaway torque

Designed for efficiency and reliability, all Valvcon™ actuators deliver the power you need when and where it is needed. With efficient gear trains and motors these actuators are rated at breakaway torque. Immediately upon power up, the actuator supplies the rated torque - when it is needed to break the valve away from its seat. Other manufacturer's actuators may be rated at running torque, but actually deliver significantly less breakaway torque.

Simplified set-up

The Valvcon™ V-Series user interface introduces a revolutionary advance in the set-up and calibration of electric actuators — SIMPLICITY!!!

With the on-board LCD and the touch of simple “enter, set and go” push buttons, the V-Series Speed Control/Timer Board simplifies actuator calibration. Push buttons and slide switches make manual positioning easy, and make set-up a snap.

Features at a glance!

- Electronics are simple to use, with a clearly labeled terminal strip and easy access to user wiring
- Plug-in electronics for simple upgrades and modifications, with coded connectors to make internal mis-wiring impossible
- Standard extended 75% duty cycle at ambient temperatures up to 104°F / 40°C
- “Captive” cover screws are permanently attached to the cover and simplify installation in awkward locations
- Thermal overload cutout protects the motor from damage caused by over duty cycle applications

Certifications and standards compliance

Certification by the Canadian Standards Association of either hazardous or weatherproof locations is standard on all V-Series models.



Enclosure Ingress Protection (IP) Rating: 66

Facility: ISO 9001:2015 certified

Compliance with the following international standards: ISO 5211, EN IEC 60079-0:2018 (WX models only), EN 60079-1:2014 (WX models only), IEC 60079-0:2017, and IEC 60079-1:2014-06.

V-series board options

(Order code J) speed control/timer board

The Speed Control feature solves the problem of the valve opening too quickly in fluid and steam applications where the resulting “hammer” or “shock” is eliminated. Both cycles, (CW and CCW) can be extended independently anywhere from the normal speed down to 1/200th the normal speed.

The Timer feature provides automatic cycling in On/Off applications where the actuation cycle can be scheduled anywhere from once every minute to once every 24 hours. The Timer and Speed Control functions can be used together or independently.

Other V-series standard and optional features

(Standard feature) tropical heater/thermostat

Useful in all high humidity applications where condensation may accumulate inside the actuator. For 115VAC applications the heater consumes 15 watts, for 230VAC applications the heater consumes 40 watts.

(Option codes I1, I2, I3, and I4) ISO 5211 Metric Output

The actuator is equipped with an ISO 5211 compliant mounting configuration.

The standard drive output for 150-600 lb-in models is a 3/4” female square. The standard drive output for 1000-3000 lb-in models is a 1” female square. We offer several female metric drive output options, consult the “How to Order” section for available sizes for a given actuator model.

(Standard feature) brake

A brake prevents the actuator from being backdriven. Required for all dampers, butterfly valves, PVC ball valves, and resilient seated valves.

(Standard feature) additional limit switches

Two additional limit switches are included for position indication or as dry contacts to operate other devices. Single pole, double throw switches rated for 1/2 HP, 11 amps 250VAC, CSA certified.

(Option codes Y1, Y2, and Y3) keyed output

The actuator is equipped with an ISO 5211 compliant mounting configuration.

The standard drive output for 150-600 lb-in models is a 3/4” female square. The standard drive output for 1000-3000 lb-in models is a 1” female square. We offer several female keyed drive output options, consult the “How to Order” section for available sizes for a given actuator model.

(Option code Z) handwheel

For manual operation when power is not available. The handwheel is disengaged from the geartrain and does not turn during normal operation. When the handwheel is pushed down, it disengages the motor from the geartrain and allows manual operation.

(VWX and LVWX) hazardous location enclosures

The standard enclosures (VW and LVW) are rated for NEMA 4/4X (weather tight and corrosion resistant). The Hazardous Location enclosures (VWX and LVWX) are Certified by CSA to meet NEMA 4/4X/7 & 9, Class I, Div 1, Groups C&D; Class II, Div. 1, Groups E, F, & G; Class III, and are also certified to ATEX Directive 2014/34/EU, IECEx CSA 14.0057X.

Certificate Number: **Sira 13ATEX1166X**



II 2 G
Ex db IIB T6 Gb
Ta = -20°C to +66°C

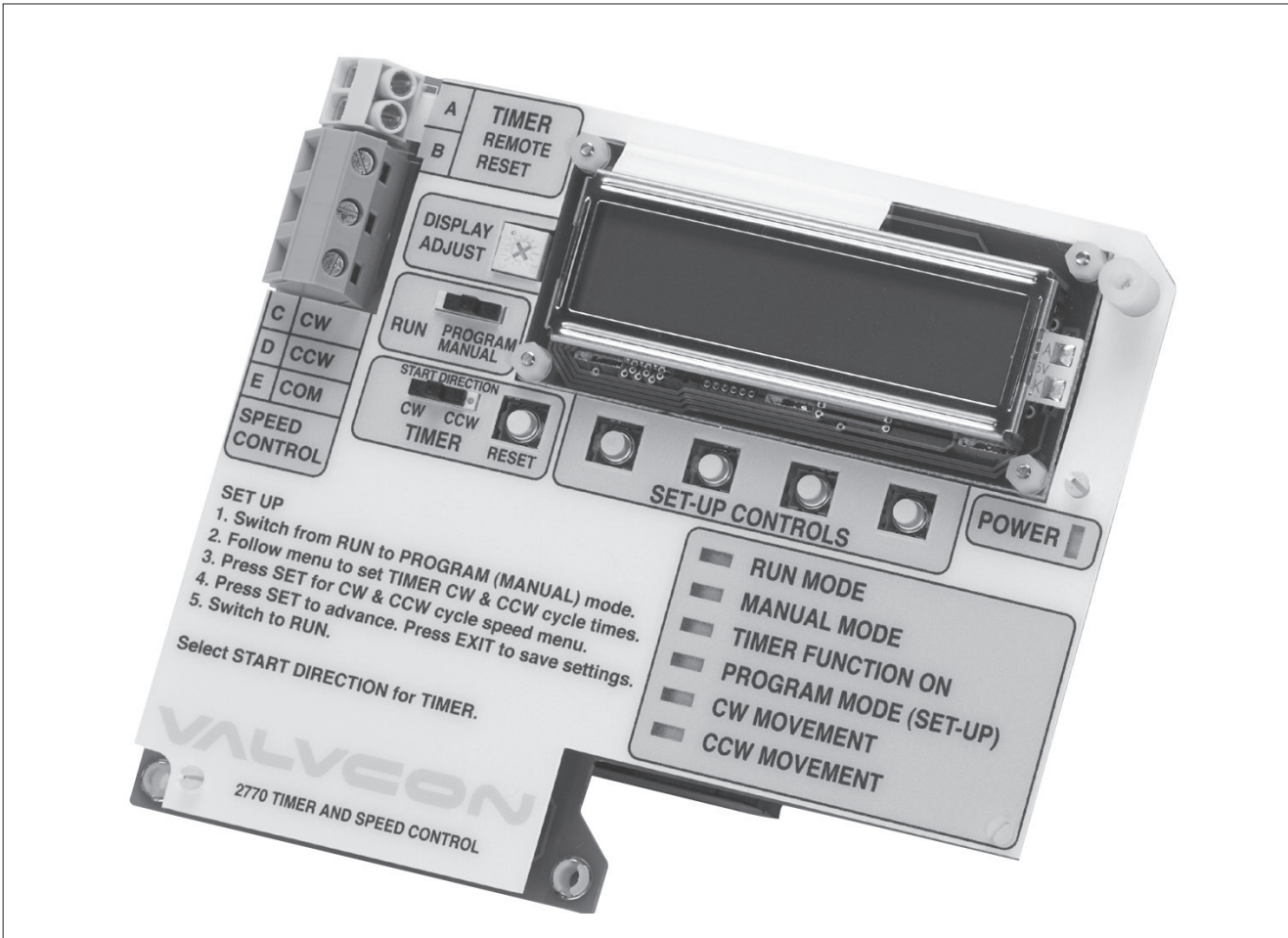

115VAC and 230VAC models*

Torque Output (Breakaway)	Speed (seconds per 90° rotation)	Duty Cycle (at/below 104°F/40°C)	Duty Cycle (at max temp; 150°F/66°C)	VA Rating		Max Running Current at Full Load (True RMS)		Max Effective Peak Inrush Current (= .66 x Peak rush)	
				115VAC 60Hz	230VAC 60Hz	115VAC 60Hz	230VAC 60Hz	115VAC 60Hz	230VAC 60Hz
150 lb-in; 12 lb-ft; 17 Nm	8	75%; 8 sec ON, 3 sec OFF	50%; 8 sec ON, 8 sec OFF	70vA	115vA	0.6 amps	0.5 amps	1.25 amps	0.924 amps
300 lb-in; 25 lb-ft; 34 Nm	15	75%; 15 sec ON, 5 sec OFF	50%; 15 sec ON, 15 sec OFF	70vA	115vA	0.6 amps	0.5 amps	1.25 amps	0.924 amps
600 lb-in; 50 lb-ft; 68 Nm	30	75%; 30 sec ON, 10 sec OFF	50%; 30 sec ON, 30 sec OFF	70vA	115vA	0.6 amps	0.5 amps	1.25 amps	0.924 amps
1000 lb-in; 83 lb-ft; 113 Nm	25	75%; 25 sec ON, 9 sec OFF	50%; 25 sec ON, 25 sec OFF	92vA	161vA	0.8 amps	0.7 amps	1.66 amps	1.29 amps
1500 lb-in; 125 lb-ft; 169 Nm	40	75%; 40 sec ON, 14 sec OFF	50%; 40 sec ON, 40 sec OFF	92vA	161vA	0.8 amps	0.7 amps	1.66 amps	1.29 amps
2000 lb-in; 167 lb-ft; 226 Nm	55	75%; 55 sec ON, 19 sec OFF	50%; 55 sec ON, 55 sec OFF	92vA	161vA	0.8 amps	0.7 amps	1.66 amps	1.29 amps
2500 lb-in; 208 lb-ft; 282 Nm	70	75%; 70 sec ON, 24 sec OFF	35%; 70 sec ON, 130 sec OFF	92vA	161vA	0.8 amps	0.7 amps	1.66 amps	1.29 amps
3000 lb-in; 250 lb-ft; 339 Nm	75	55%; 75 sec ON, 62 sec OFF	25%; 75 sec ON, 225 sec OFF	92vA	161vA	0.8 amps	0.7 amps	1.66 amps	1.29 amps

*Notes:
The Maximum Current stated above includes all options. If the brake and/or heater & thermostat are not installed, the actual current draws will be less.

V-SERIES ENCLOSURES (150-600 LB-IN)

Mounting Flange, ISO 5211 F05 / F07

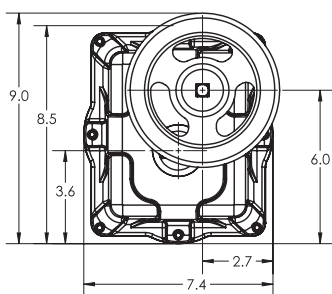

4 X M6-1.0 ∇ 0.75 MIN.
ON 1.969" B.C.

4 X M8-1.25 ∇ 0.75 MIN.
ON \varnothing 2.756" B.C.

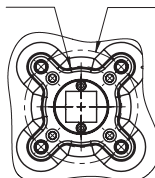

Female Square Drive

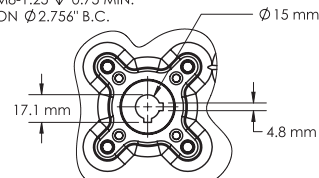

Female Keyed Drive

Actuator Size	Drive Option	Drive Type	Drive Size	Depth
150-600 lb-in (12-50 lb-ft; 17-68 Nm)	Standard	Square	0.750 (19mm)	0.90 (22.9mm)
150-600 lb-in (12-50 lb-ft; 17-68 Nm)	Option "I1"	Double Square	0.551 (14mm)	0.90 (22.9mm)
150-600 lb-in (12-50 lb-ft; 17-68 Nm)	Option "I2"	Square	0.669 (17mm)	0.90 (22.9mm)
150-600 lb-in (12-50 lb-ft; 17-68 Nm)	Option "Y1"	Keyed	0.591 (15mm)	1.40 (35.6mm)
150-600 lb-in (12-50 lb-ft; 17-68 Nm)	Option "Y2"	Keyed	0.787 (20mm)	1.40 (35.6mm)

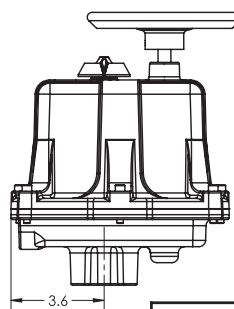
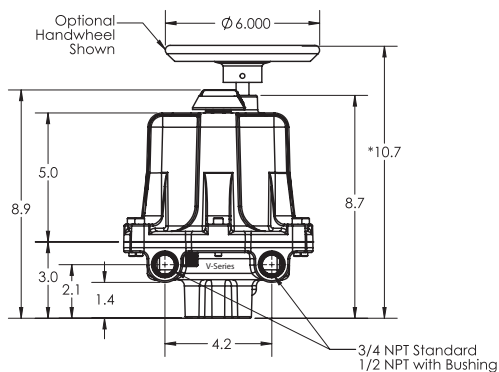

Approximate Weight	17 lb / 8 kg
---------------------------	--------------

*9.7 WITHOUT HANDWHEEL
TO REMOVE COVER REQUIRES AN ADDITIONAL 4.75"

All Dimensions in inches unless otherwise stated

V-SERIES ENCLOSURES (1000-3000 LB-IN)

Mounting Flange, ISO 5211 F07 / F10

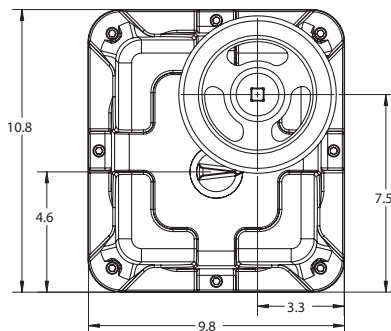

4 X M8-1.25 ∇ 0.75" MIN.
ON \varnothing 2.756" B.C.

4 X M10-1.5 ∇ 0.75" MIN.
ON \varnothing 4.016" B.C.

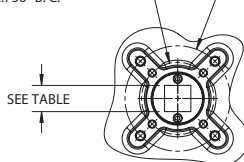

Female Square Drive

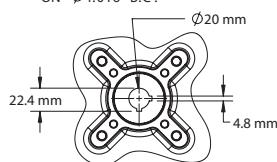

Female Keyed Drive

Actuator Size	Drive Option	Drive Type	Drive Size	Depth
1000-3000 lb-in (83-250 lb-ft; 113-339 Nm)	Standard	Square	1.000 (25mm)	1.20 (30.5mm)
1000-3000 lb-in (83-250 lb-ft; 113-339 Nm)	Option "I2"	Double Square	0.669 (17mm)	1.20 (30.5mm)
1000-3000 lb-in (83-250 lb-ft; 113-339 Nm)	Option "I3"	Double Square	0.748 (19mm)	1.20 (30.5mm)
1000-3000 lb-in (83-250 lb-ft; 113-339 Nm)	Option "I4"	Double Square	0.866 (22mm)	1.20 (30.5mm)
1000-3000 lb-in (83-250 lb-ft; 113-339 Nm)	Option "Y2"	Keyed	0.787 (20mm)	1.50 (38.1mm)
1000-3000 lb-in (83-250 lb-ft; 113-339 Nm)	Option "Y3"	Keyed	0.984 (25mm)	1.50 (38.1mm)

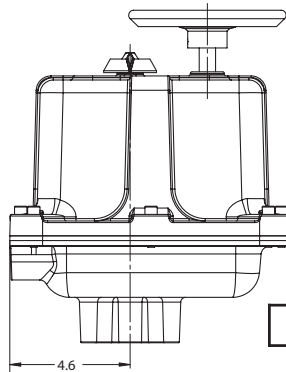
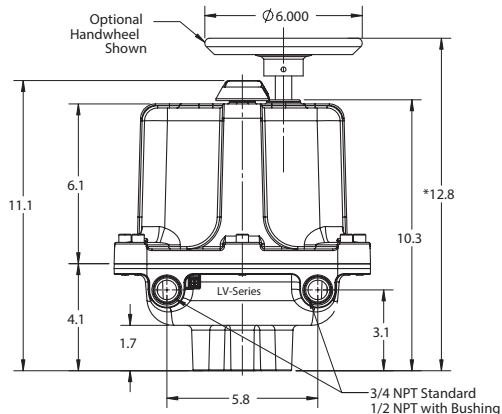

Approximate Weight	31 lb / 14 kg
---------------------------	---------------

*11.7 WITHOUT HANDWHEEL
TO REMOVE COVER REQUIRES AN ADDITIONAL 5.75"

All Dimensions in inches unless otherwise stated

115VAC and 230VAC ON/OFF standard

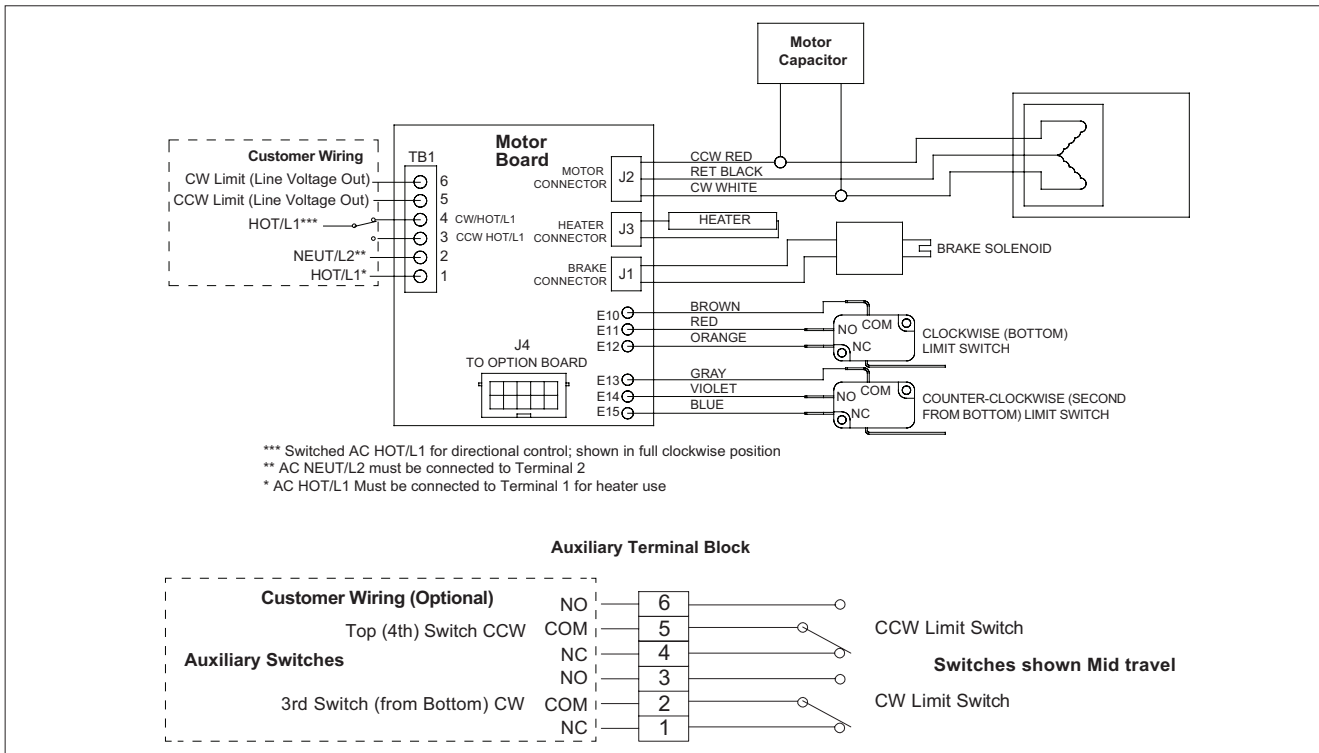

115VAC and 230VAC with optional control board

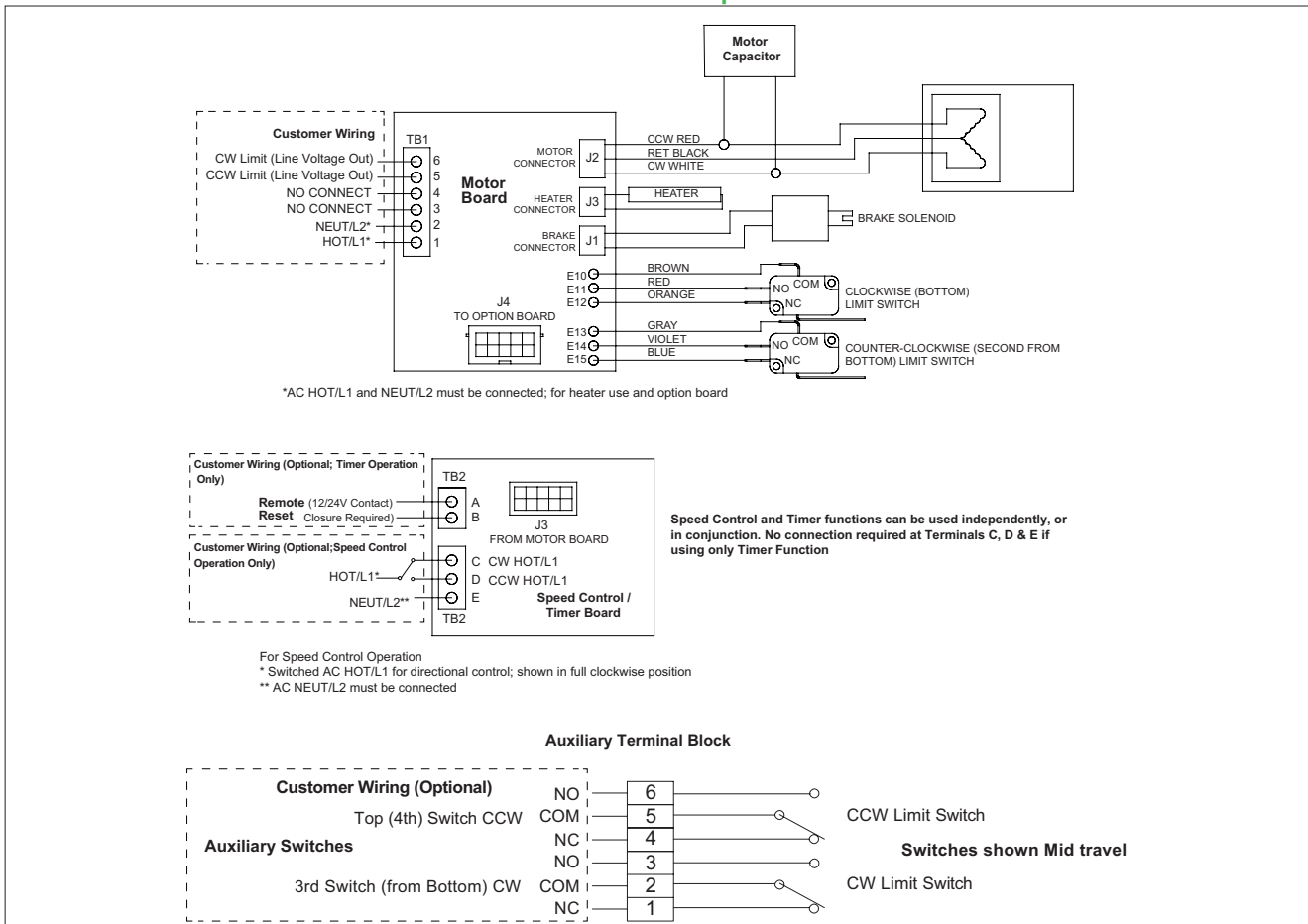

WARNING: As the use of the actuator is application specific, a number of factors should be taken into account when selecting an actuator for a given application. Therefore, some of the applications in which the actuators are used are outside the scope of this document. If you have questions concerning the use, application or compatibility of the actuator with the intended service, contact Valmet for more information.

How to order – V-series electric actuators (150-600 lb-in)

Example:

Sample model code: VWX300JI2N115AC

1	Series
V	V
2	Enclosure
W	Weathertight (NEMA 4/4X)
WX	Weathertight & Explosion proof (NEMA 4/4X/7&9); ATEX, and IECEx
3	Torque
150	150 lb-in (12 lb-ft; 17 Nm)
300	300 lb-in (25 lb-ft; 34 Nm)
600	600 lb-in (50 lb-ft; 68 Nm)
4	Board option ⁽¹⁾
J	Speed Control/Timer Board

1	2	3	4	5	6
V	WX	300	J	I2	N115AC

5	Other options
I1 ⁽²⁾	14mm Female Square Output
I2 ⁽²⁾	17mm Female Square Output
Y1 ⁽²⁾	15mm Female Keyed Output
Y2 ⁽²⁾	20mm Female Keyed Output
Z	Handwheel

6	Operating voltage
N115AC	115AC
N230AC	230AC

How to order – V-series electric actuators (1000-3000 lb-in)

Example:

Sample model code: LVW2000Y3ZN230AC

1	Series
LV	LV
2	Enclosure
W	Weathertight (NEMA 4/4X)
WX	Weathertight & Explosion proof (NEMA 4/4X/7&9); ATEX, and IECEx
3	Torque
1000	1000 lb-in (83 lb-ft; 113 Nm)
1500	1500 lb-in (125 lb-ft; 169 Nm)
2000	2000 lb-in (167 lb-ft; 226 Nm)
2500	2500 lb-in (208 lb-ft; 282 Nm)
3000	3000 lb-in (250 lb-ft; 339 Nm)
4	Board option ⁽¹⁾
J	Speed Control/Timer Board

1	2	3	4	5	6
LV	W	2000	-	Y3, Z	N230AC

5	Other options
I2 ⁽²⁾	17mm Female Square Output
I3 ⁽²⁾	19mm Female Square Output
I4 ⁽²⁾	22mm Female Square Output
Y2 ⁽²⁾	20mm Female Keyed Output
Y3 ⁽²⁾	25mm Female Keyed Output
Z	Handwheel

6	Operating voltage
N115AC	115AC
N230AC	230AC

Notes:

1. Select board option, as needed; board option is not required for On/Off operation.
2. The standard drive output for 150 - 600 lb-in actuators is a 3/4" female square; the standard drive output for 1000 - 3000 lb-in actuators is a 1" female square.

Valmet Flow Control Oy

Vanha Porvoontie 229, 01380 Vantaa, Finland.

Tel. +358 10 417 5000.

www.valmet.com/flowcontrol

Subject to change without prior notice.

Neles, Neles Easyflow, Jamesbury, Stonel, Valvcon and Flowrox, and certain other trademarks, are either registered trademarks or trademarks of Valmet Oyj or its subsidiaries in the United States and/or in other countries.

For more information www.neles.com/trademarks

