

# Bettis CBA-300 Series

Pneumatic Actuators



*This page intentionally left blank*

## Table of Contents

<b>Section 1: Introduction</b>	
Introduction.....	5
<b>Section 2: Torque Ratings - (Pneumatic)</b>	
Double-Acting Actuators.....	6
Spring-Return Actuators.....	7
<b>Section 3: Performance Data - (Pneumatic)</b>	
Double-Acting Actuators.....	9
Spring-Return Actuators.....	9
<b>Section 4: Dimensions (mm)</b>	
Double-Acting Actuators - CBAX30 .....	10
<b>Section 5: Dimensions (mm)</b>	
Spring-Return Actuators - CBAX30-SRX .....	12
<b>Section 6: Dimensions (mm) - M3 (HW) Override</b>	
Double-Acting Actuators - CBAX30-M3 (HW) .....	13
<b>Section 7: Dimensions (mm) - M3 (HW) Override</b>	
Spring-Return Actuators - CBAX30-SRX-M3 (HW).....	14
<b>Section 8: Dimensions (mm) - Hydraulic Override</b>	
Double-Acting Actuators - CBAX30-M18 .....	15
Spring-Return Actuators - CBAX30-SRX-M18 .....	15
<b>Section 9: Dimensions (mm) - Hydraulic Override</b>	
Double-Acting Actuators - CBAX30-M11 .....	16
Spring-Return Actuators - CBAX30-SRX-M11 .....	16
<b>Section 10: Dimensions (mm) - Hydraulic Override</b>	
Dimensions (mm) - Hydraulic Override .....	17

*This page intentionally left blank*

## Introduction

The Bettis™ CBA-300 Series pneumatic actuators incorporate the most advanced features from a long history of developments in the scotch yoke design, assuring operating efficiency and cost-effectiveness. They are lightweight and compact, making them ideally suited for automating virtually any quarter-turn (90°) rotating mechanism, including ball, butterfly, and plug valves. They are economical and require little maintenance. They come with a variety of options to meet your demanding valve automation needs.

- Ductile iron or carbon steel housing and piston provide more strength per pound, increased durability and corrosion resistance. The pressure vessel quality housing is approved for use by ASME and the Pressure Equipment Directive (PED) 2014/68/EU.
- Increased actuator efficiency and corrosion resistance is possible with a Xylan fluoropolymer coating on the interior of the power cylinder. This permanently bonded coating is highly resistant to abrasion, thermal shock and provides excellent lubricity and low friction properties.
- The 300-Series actuators meet both IP66 and IP67M specifications for submergence and severe high pressure water deluge test. This offers superior water ingress and corrosion protection. The actuator has no gaskets and is totally O-ring sealed.
- The scotch yoke design provides optimum torque curves for quarter-turn operation.
- Its light weight assists in easy installation while its compactness allows use in tight piping configurations.
- Jackscrew and hydraulic override options.
- Five-Year Warranty.
- Its NAMUR topworks mounting configuration allows the CBA-300 to be internationally accepted and promotes the ability to utilize standardized accessories that can be close coupled or direct mounted to the valve.
- Suitable for SIL 1, 2 or 3.
- The CBA-300 Series provides models in both spring-return and double-acting configurations. They have guaranteed minimum torque outputs ranging from 879 to 2,303 Nm in double-acting models. Spring-Return models, requiring pressure from only one travel direction, are available for fail clockwise or counterclockwise applications. The spring ending torques range from 259 to 1,133 Nm.

# Torque Ratings - (Pneumatic)

## Double-Acting Actuators

### CBA-300 Series

All Published Torques are Guaranteed Minimum Values (Units are Metric).

Table 1.

Actuator Model	Stroke Direction Start/Min./End		Operating Pressure (barg)																MinOP (barg)	Torque @ MinOP (Nm)	MOP (barg)	Torque @ MOP (Nm)	
			2.5	3	3.5	3.8	4	4.5	5	5.2	5.5	6	6.2	6.5	7	7.2	7.5	8					8.2
			Pressure Torque Output Start/Min./End (Nm)																				
CBA730	Start	Outboard	Please consult factory	884	1,039	1,132	1,194	1,349	1,505	1,567	1,660	1,815	1,877	1,970	2,125	2,187	Exceeds MOP	-	-	2.8	822	7.2	2,187
	Minimum			470	551	599	632	713	794	826	875	956	988	1,037	1,118	1,150		-	-		437		1,150
	End			899	1,054	1,147	1,209	1,364	1,519	1,581	1,674	1,829	1,891	1,984	2,139	2,201		-	-		837		2,201
	Start	Inboard		879	1,033	1,125	1,187	1,341	1,495	1,557	1,650	1,804	1,866	1,958	2,112	2,174		-	-		817		2,174
	Minimum			470	551	599	632	713	794	826	875	956	988	1,037	1,118	1,150		-	-		437		1,150
	End			904	1,060	1,154	1,216	1,372	1,528	1,590	1,684	1,840	1,902	1,996	2,152	2,214		-	-		842		2,214
CBA830	Start	Outboard	Please consult factory	1,170	1,374	1,496	1,578	1,782	1,986	2,067	2,189	Exceeds MOP	-	-	-	-	-	-	-	2.8	1,089	5.5	2,189
	Minimum			620	726	790	833	939	1,045	1,088	1,152		-	-	-	-	-	-	-		577		1,152
	End			1,186	1,390	1,512	1,593	1,797	2,001	2,082	2,204		-	-	-	-	-	-	-		1,105		2,204
	Start	Inboard		1,163	1,366	1,487	1,568	1,771	1,974	2,055	2,176		-	-	-	-	-	-	-		1,082		2,176
	Minimum			620	726	790	833	939	1,045	1,088	1,152		-	-	-	-	-	-	-		577		1,152
	End			1,194	1,398	1,521	1,603	1,808	2,013	2,095	2,218		-	-	-	-	-	-	-		1,112		2,218
CBA930	Start	Outboard	Please consult factory	1,496	1,755	1,910	2,014	2,273	Exceeds MOP	-	-	-	-	-	-	-	-	-	-	2.8	1,392	4.5	2,273
	Minimum			790	926	1,007	1,061	1,196		-	-	-	-	-	-	-	-	-	-		736		1,196
	End			1,513	1,771	1,927	2,030	2,289		-	-	-	-	-	-	-	-	-	-		1,409		2,289
	Start	Inboard		1,487	1,744	1,898	2,001	2,259		-	-	-	-	-	-	-	-	-	-		1,384		2,259
	Minimum			790	926	1,007	1,061	1,196		-	-	-	-	-	-	-	-	-	-		736		1,196
	End			1,522	1,782	1,938	2,042	2,303		-	-	-	-	-	-	-	-	-	-		1,418		2,303
CBA1030	Start	Outboard	Please consult factory	1,989	Exceeds MOP	-	-	-	-	-	-	-	-	-	-	-	-	2.8	1,852	3.4	2,263		
	Minimum			1,049		-	-	-	-	-	-	-	-	-	-	-	-		-		977	1,192	
	End			2,007		-	-	-	-	-	-	-	-	-	-	-	-		-		1,871	2,281	
	Start	Inboard		1,977		-	-	-	-	-	-	-	-	-	-	-	-		-		1,841	2,249	
	Minimum			1,049		-	-	-	-	-	-	-	-	-	-	-	-		-		977	1,192	
	End			2,020		-	-	-	-	-	-	-	-	-	-	-	-		-		-	1,882	2,295

## Spring-Return Actuators

### CBA-300 Series

All Published Torques are Guaranteed Minimum Values (Units are Metric).

Table 2.

Actuator Model	Stroke Direction Start/Min./End		Operating Pressure (barg)																MinOP (barg)	Torque @ MinOP (Nm)	MOP (barg)	Torque @ MOP (Nm)			
			2.5	3	3.5	3.8	4	4.5	5	5.5	6	7	7.5	8.5	9	10	10.5	11					11.5		
			Pressure Torque Output Start/Min./End (Nm)																						
CBA730-SR40	Start	459	385	531	677	765	823	969	1,115	1,260	1,406	1,698	1,844	2,136	2,282	Exceeds MOP	-	-	-	2.4	356	9.3	2,370		
	Minimum	187	150	228	306	352	383	460	537	614	691	844	921	1,074	1,151		-	-	-		134		1,197		
	End	259	192	339	487	575	634	782	929	1,077	1,224	1,519	1,667	1,962	2,110		-	-	-		162		2,198		
CBA730-SR60	Start	724	-	-	Please consult factory	631	689	835	981	1,127	1,273	1,565	1,711	2,003	2,149	Exceeds MOP	-	-	-	3.6	573	9.7	2,353		
	Minimum	287	-	-		241	273	352	429	507	584	738	815	969	1,046		-	-	-		209		1,153		
	End	393	-	-		309	368	516	663	811	958	1,254	1,401	1,696	1,844		-	-	-		250		2,050		
CBA730-SR80	Start	1,022	-	-	-	-	-	Please consult factory	885	1,031	1,177	1,469	1,615	1,906	2,052	2,344	Exceeds MOP	-	-	-	5.0	885	10.0	2,344	
	Minimum	382	-	-	-	-	-		313	394	473	629	707	862	939	1,093		-	-	-		313		1,093	
	End	489	-	-	-	-	-		-	365	513	660	955	1,103	1,398	1,545		1,841	-	-		-		365	1,841
CBA730-SR100	Start	1,282	-	-	-	-	-	-	-	-	Please consult factory	1,338	1,484	1,776	1,922	2,214	Exceeds MOP	-	-	-	6.2	1,104	10.3	2,301	
	Minimum	481	-	-	-	-	-	-	-	-		519	598	755	832	987		-	-	-		390		1,034	
	End	620	-	-	-	-	-	-	-	-		-	694	841	1,136	1,284		1,579	-	-		-		458	1,668
CBA830-SR40	Start	609	517	708	900	1,015	1,092	1,283	1,475	1,667	1,858	2,242	Exceeds MOP	-	-	-	-	-	-	2.4	478	7.2	2,318		
	Minimum	248	201	304	406	467	508	609	710	811	911	1,113		-	-	-	-	-	-		-		180	1,153	
	End	346	261	454	648	764	842	1,036	1,229	1,423	1,617	2,004		-	-	-	-	-	-		-		222	2,082	
CBA830-SR60	Start	989	-	-	Please consult factory	876	952	1,144	1,336	1,527	1,719	2,102	2,294	Exceeds MOP	-	-	-	-	-	-	3.7	837	7.6	2,333	
	Minimum	375	-	-		318	360	465	567	669	771	974	1,075		-	-	-	-	-	-		-		296	1,095
	End	486	-	-		384	461	655	849	1,043	1,236	1,624	1,818		-	-	-	-	-	-		-		345	1,856
CBA830-SR80	Start	1,357	-	-	-	-	-	Please consult factory	1,184	1,376	1,568	1,951	2,143	Exceeds MOP	-	-	-	-	-	-	5.0	1,184	7.9	2,296	
	Minimum	503	-	-	-	-	-		414	521	625	831	933		-	-	-	-	-	-		-		414	1,014
	End	637	-	-	-	-	-		-	479	673	867	1,254		1,448	-	-	-	-	-		-		479	1,603
CBA830-SR100	Start	1,737	-	-	-	-	-	-	-	-	Please consult factory	1,811	2,003	Exceeds MOP	-	-	-	-	-	-	6.3	1,543	8.3	2,310	
	Minimum	629	-	-	-	-	-	-	-	-		680	785		-	-	-	-	-	-		-		531	950
	End	777	-	-	-	-	-	-	-	-		-	874		1,067	-	-	-	-	-		-		602	1,377

## Spring-Return Actuators

### CBA-300 Series

All Published Torques are Guaranteed Minimum Values (Units are Metric).

Table 3.

Actuator Model	Stroke Direction Start/Min./End		Operating Pressure (barg)																	MinOP (barg)	Torque @ MinOP (Nm)	MOP (barg)	Torque @ MOP (Nm)
			2.5	3	3.5	3.8	4	4.5	5	5.5	6	7	7.5	8.5	9	10	10.5	11	11.5				
			Pressure Torque Output Start/Min./End (Nm)																				
CBA930-SR40	Start	783	666	910	1,153	1,300	1,397	1,641	1,884	2,128	Exceeds MOP	-	-	-	-	-	-	-	-	2.4	618	5.9	2,323
	Minimum	318	259	390	519	597	648	777	905	1,033		-	-	-	-	-	-	-	-		232		1,136
	End	445	338	584	830	977	1,076	1,322	1,568	1,814		-	-	-	-	-	-	-	-		288		2,011
CBA930-SR60	Start	1,290	-	-	Please consult factory	1,156	1,254	1,497	1,741	1,985	2,228	Exceeds MOP	-	-	-	-	-	-	-	3.8	1,156	6.2	2,326
	Minimum	473	-	-		405	460	593	724	854	984		-	-	-	-	-	-	-		405		1,035
	End	588	-	-		469	567	814	1,060	1,306	1,552		-	-	-	-	-	-	-		469		1,651
CBA930-SR80	Start	1,736	-	-	-	-	-	Please consult factory	1,523	1,766	2,010	Exceeds MOP	-	-	-	-	-	-	-	5.0	1,523	6.6	2,302
	Minimum	640	-	-	-	-	-		531	666	799		-	-	-	-	-	-	-		531		956
	End	807	-	-	-	-	-		613	859	1,105		-	-	-	-	-	-	-		613		1,400
CBA930-SR100	Start	2,184	-	-	-	-	-	Please consult factory	-	-	-	Exceeds MOP	2,275	-	-	-	-	-	-	6.3	1,933	7.2	2,372
	Minimum	809	-	-	-	-	-		-	-	-		870	-	-	-	-	-	-		682		923
	End	1,030	-	-	-	-	-		-	-	-		1,148	-	-	-	-	-	-		803		1,247
CBA1030-SR40	Start	1,053	902	1,224	1,546	1,740	1,868	2,191	Exceeds MOP	-	-	-	-	-	-	-	-	-	-	2.4	838	4.8	2,384
	Minimum	423	346	520	691	794	862	1,032		-	-	-	-	-	-	-	-	-	311		1,133		
	End	587	449	774	1,099	1,295	1,425	1,750		-	-	-	-	-	-	-	-	-	383		1,945		
CBA1030-SR60	Start	1,733	-	-	Please consult factory	1,573	1,702	2,024	2,346	Exceeds MOP	-	-	-	-	-	-	-	-	-	3.8	1,573	5.2	2,475
	Minimum	622	-	-		541	614	790	964		-	-	-	-	-	-	-	-	-		541		1,033
	End	755	-	-		612	743	1,068	1,393		-	-	-	-	-	-	-	-	-		612		1,524
CBA1030-SR80	Start	2,261	-	-	-	-	-	Please consult factory	1,968	2,291	Exceeds MOP	-	-	-	-	-	-	-	-	4.9	1,904	5.5	2,291
	Minimum	860	-	-	-	-	-		711	888		-	-	-	-	-	-	-	-		675		888
	End	1,133	-	-	-	-	-		864	1,189		-	-	-	-	-	-	-	-		799		1,189



## Performance Data - (Pneumatic)

### Double-Acting Actuators

#### CBA-300 Series

All Published Torques are Guaranteed Minimum Values (Units are Metric).

Table 4.

Actuator Model	Volume (cu cm.) ▲		Maximum Operating Pressure (MOP)* (bar)	Maximum Allowable Working Pressure (MAWP)** (bar)	Approximate Weight of Actuator (kg)	
	Outboard	Inboard (Housing)			Ductile Iron Housing	Carbon Steel Housing
CBA730	4260.6	9209.5	7.2	13.8	50.9	53.2
CBA830	5588.0	10373.0	5.5	13.8	56.7	58.9
CBA930	7095.6	11683.9	4.5	11.7	62.9	65.1
CBA1030	9373.4	13666.8	3.4	9.0	69.9	72.1

### Spring-Return Actuators

#### CBA-300 Series

All Published Torques are Guaranteed Minimum Values (Units are Metric).

Table 5.

Actuator Model	Volume (cu cm.) ▲	Maximum Operating Pressure (MOP)* (bar)	Maximum Allowable Working Pressure (MAWP)** (bar)	Approximate Weight of Actuator (kg)	
				Ductile Iron Housing	Carbon Steel Housing
CBA730-SR40	9209.5	9.3	13.8	61.6	64.3
CBA730-SR60	9209.5	9.7	13.8	62.6	65.3
CBA730-SR80	9209.5	10.0	13.8	63.6	66.3
CBA730-SR100	9209.5	10.3	13.8	64.0	66.8
CBA830-SR40	10373.0	7.2	13.8	68.2	71.1
CBA830-SR60	10373.0	7.6	13.8	70.1	72.9
CBA830-SR80	10373.0	8.0	13.8	71.6	74.4
CBA830-SR100	10373.0	8.3	13.8	73.5	76.3
CBA930-SR40	11683.9	5.9	11.7	75.3	78.3
CBA930-SR60	11683.9	6.2	11.7	78.2	81.1
CBA930-SR80	11683.9	6.6	11.7	80.1	83.1
CBA930-SR100	11683.9	7.2	11.7	83.6	86.6
CBA1030-SR40	13666.8	4.8	9.0	85.0	88.1
CBA1030-SR60	13666.8	5.2	9.0	87.3	90.4
CBA1030-SR80	13666.8	5.5	9.0	90.8	93.9

**NOTES:**

- ◆ CB-SRXXM mechanical handwheel overrides are available on these models. The override adds approximately 0.8 kg (2 lb) to the weight of the standard CB model.
- ▲ Maximum volume including cavity required for calculating consumption per stroke.
- \* **Maximum Operating Pressure (MOP)** is the pressure required to produce the maximum rated torque of the actuator.
- \*\* **Maximum Allowable Working Pressure (MAWP)** is the maximum static pressure that may be applied to a fully stroked actuator against the travel stops. Standard installation produces clockwise rotation when the outboard side of piston is pressurized. Standard installation produces counterclockwise rotation when the inboard side of piston is pressurized. Note: Actuator may be installed opposite of that shown above.



## Dimensions (mm)

### Double-Acting Actuators - CBAX30

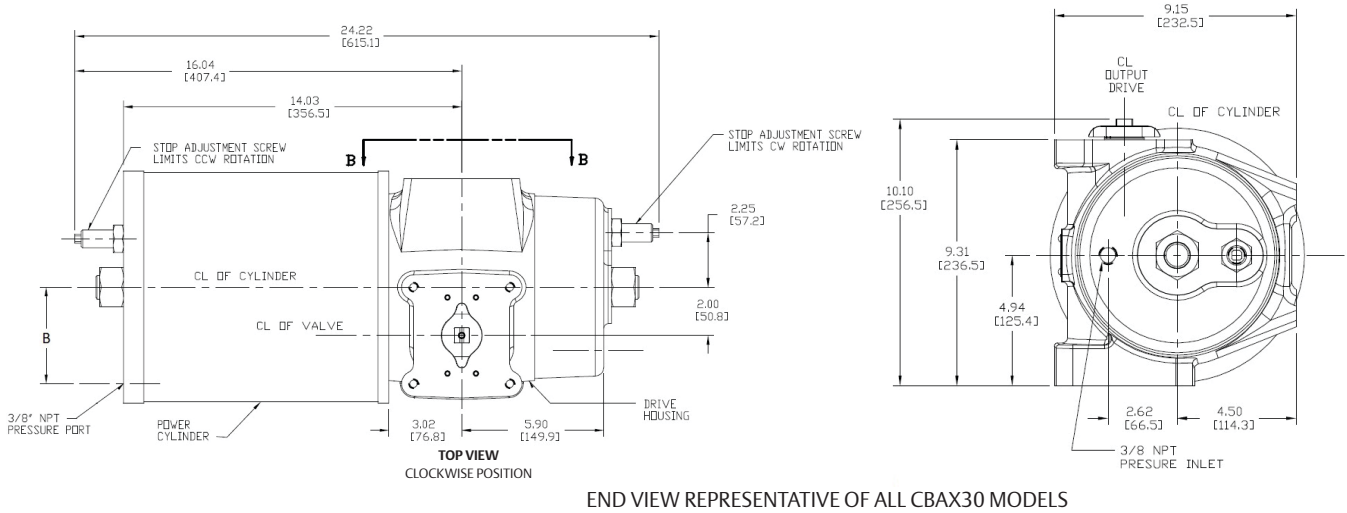

ACTUATORS SHOWN ROTATED TO FULL CLOCKWISE POSITION

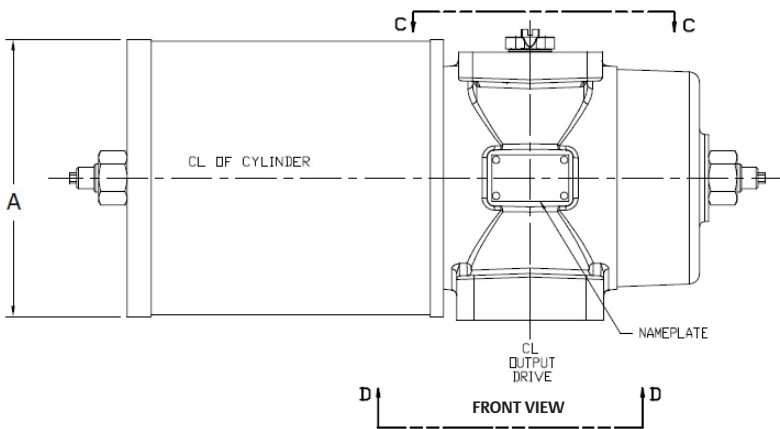

Actuator Model	A	B
CBA730	193.8	76.2
CBA830	219.2	88.9
CBA930	244.6	101.6
CBA1030	276.4	114.3

**NOTES:**

Actuators shown rotated to full clockwise position.  
Not Certified dimensional drawings. Such drawings available on request.  
Contact factory with correct model designation and serial number.  
All dimensions are expressed in mm.

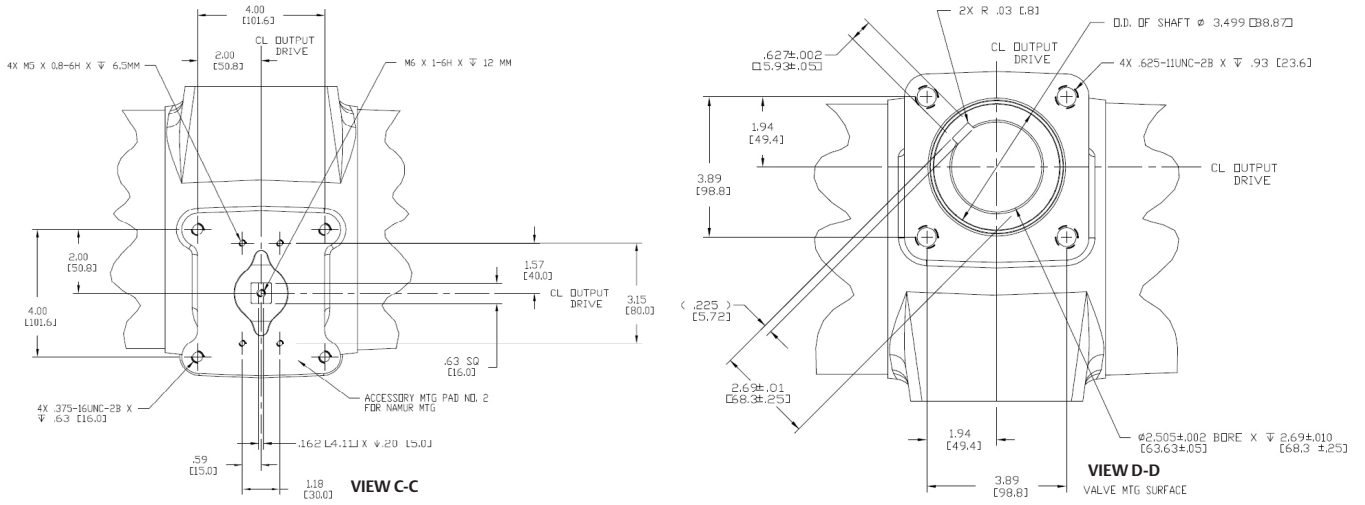

ACTUATORS SHOWN ROTATED TO FULL CLOCKWISE POSITION

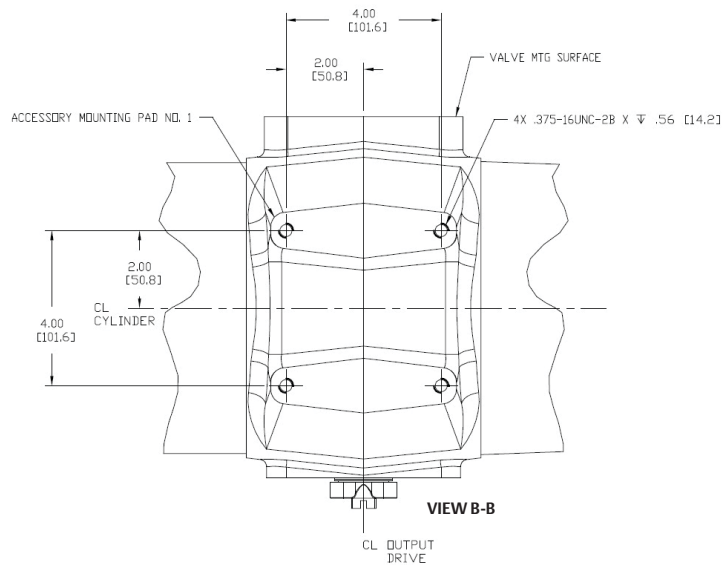

## Dimensions (mm)

### Spring-Return Actuators - CBAX30-SRX

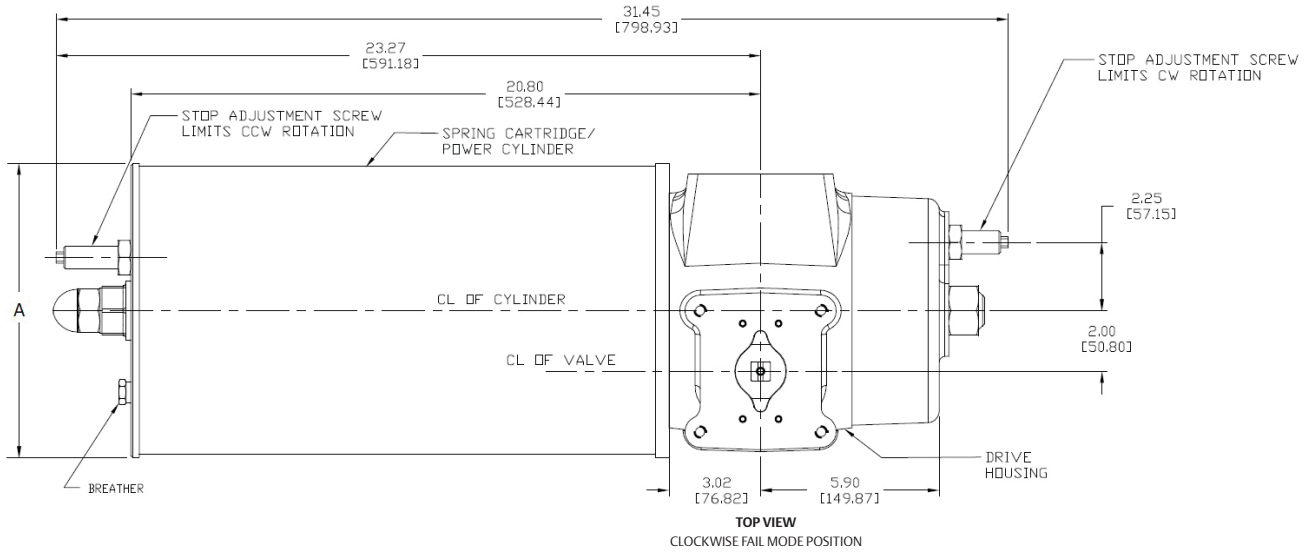

Actuator Model	A
CBA730-SRX	195.3
CBA830-SRX	220.7
CBA930-SRX	246.1
CBA1030-SRX	279.4

**NOTES:**  
 Other dimensions refer to Double-Acting page.  
 Not Certified dimensional drawings. Such drawings available on request.  
 Contact factory with correct model designation and serial number.  
 All dimensions are expressed in mm.

## Dimensions (mm) - M3 (HW) Override Double-Acting Actuators - CBAX30-M3 (HW)

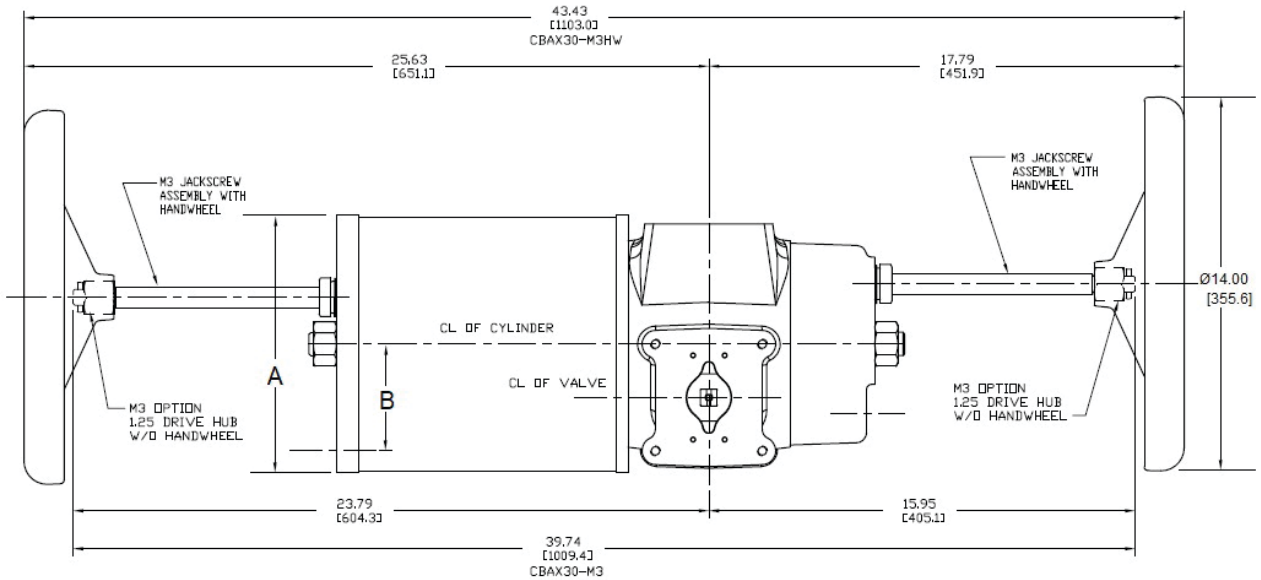

Actuator Model	A	B
CBA730-M3HW	193.8	76.2
CBA830-M3HW	219.2	88.9
CBA930-M3HW	244.6	101.6
CBA1030-M3HW	276.4	114.3

**NOTES:**

Other dimensions refer to base actuator pages.  
 Not Certified dimensional drawings. Such drawings available on request.  
 Contact factory with correct model designation and serial number.  
 All dimensions are expressed in mm.

## Dimensions (mm) - M3 (HW) Override Spring-Return Actuators - CBAX30-SRX-M3 (HW)

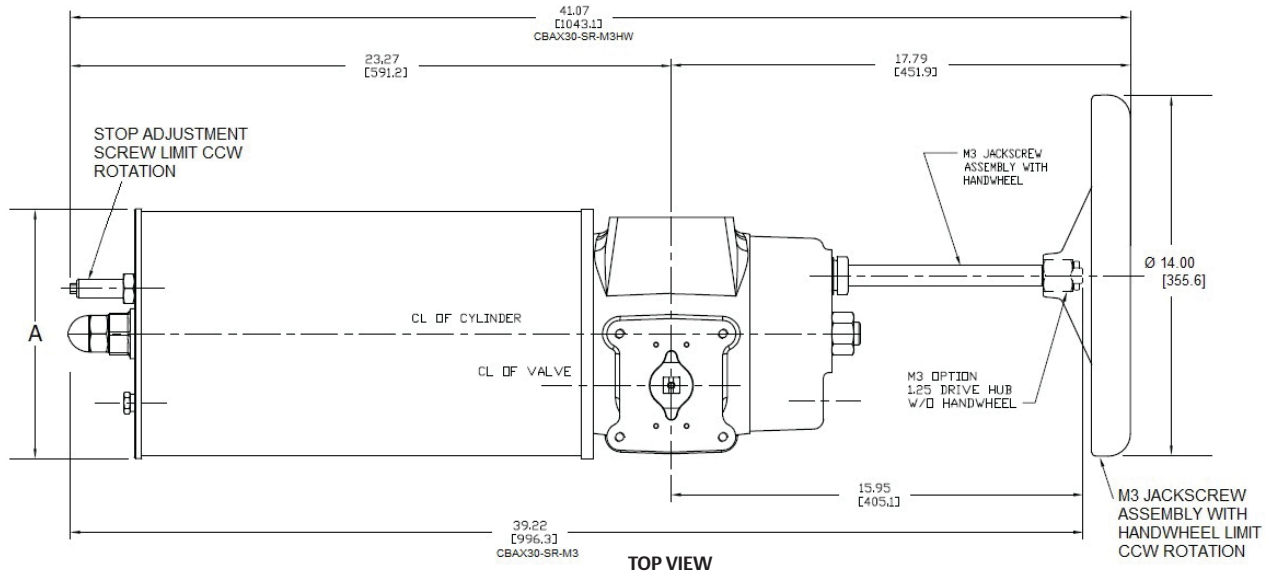

Actuator Model	A
CBA730-SRX-M3HW	195.3
CBA830-SRX-M3HW	220.7
CBA930-SRX-M3HW	246.1
CBA1030-SRX-M3HW	279.4

**NOTES:**  
Other dimensions refer to base actuator pages.  
Not Certified dimensional drawings. Such drawings available on request.  
Contact factory with correct model designation and serial number.  
All dimensions are expressed in mm.

## Dimensions (mm) - Hydraulic Override Double-Acting Actuators - CBAX30-M18

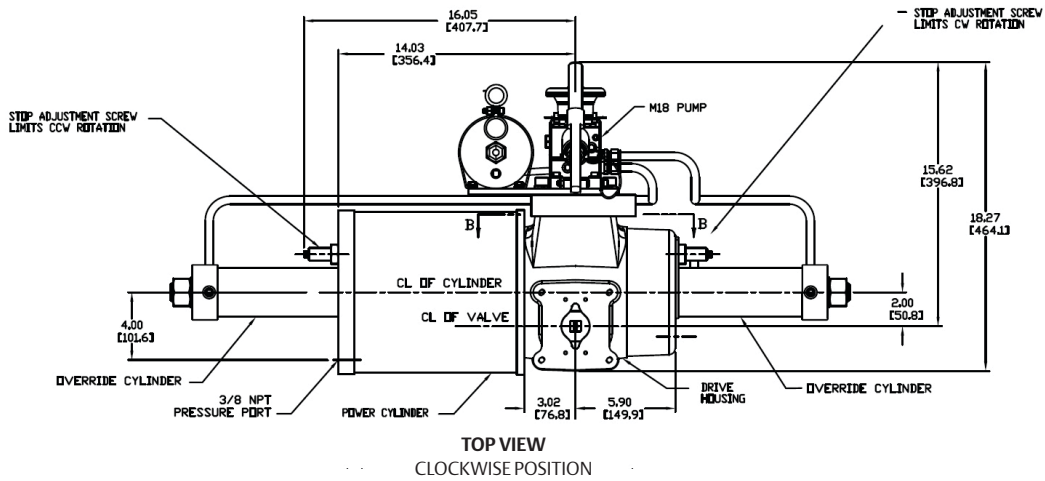

ACTUATORS SHOWN ROTATED TO FULL CLOCKWISE POSITION

## Spring-Return Actuators - CBAX30-SRX-M18

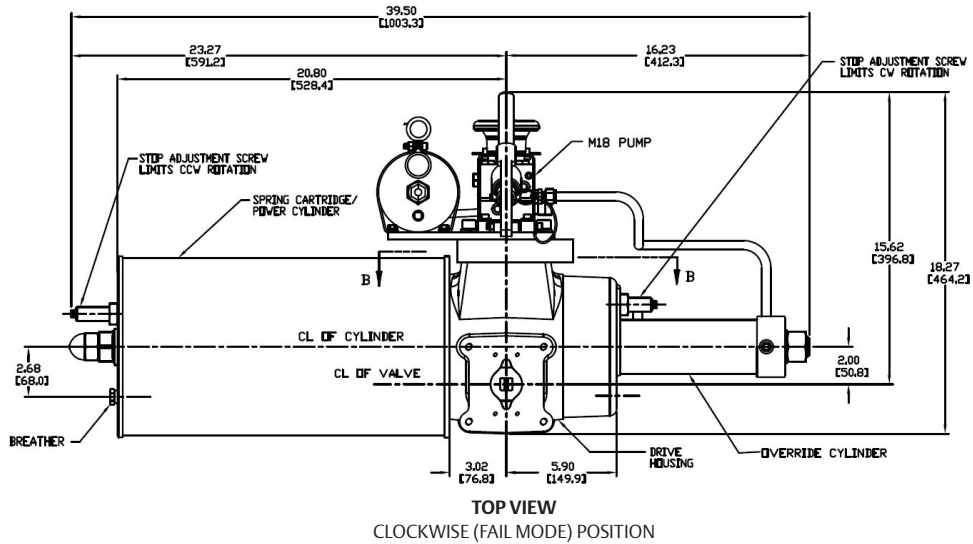

**NOTES:**

Other dimensions refer to base actuator pages.  
 Not Certified dimensional drawings. Such drawings available on request.  
 Contact factory with correct model designation and serial number.  
 All dimensions are expressed in mm.

## Dimensions (mm) - Hydraulic Override Double-Acting Actuators - CBAX30-M11

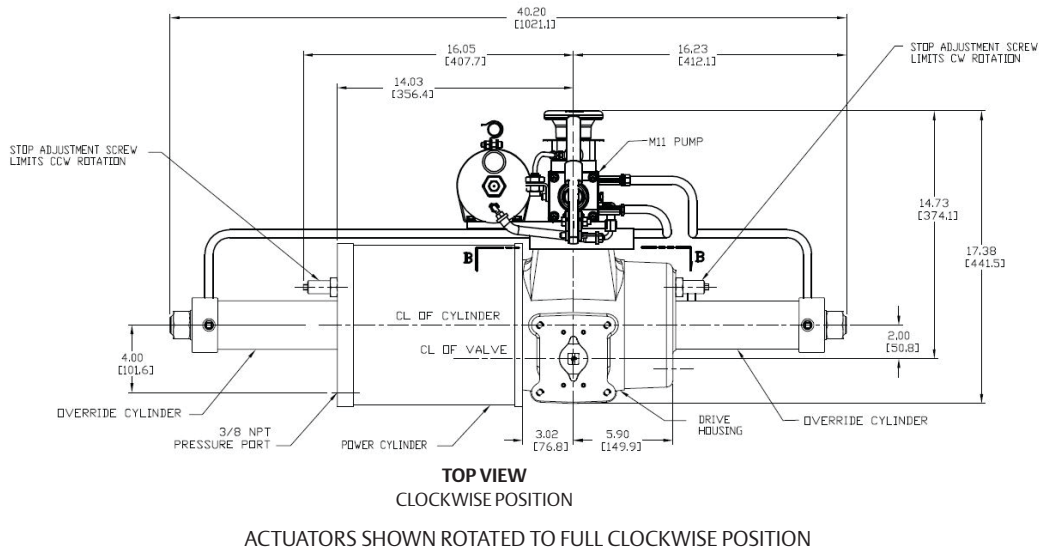

## Spring-Return Actuators - CBAX30-SRX-M11

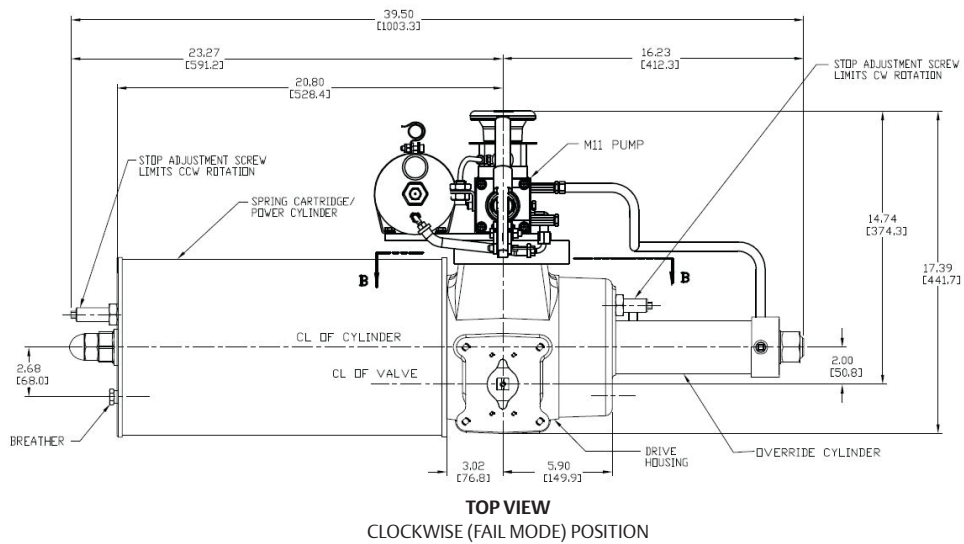

**NOTES:**

Other dimensions refer to base actuator pages.  
 Not Certified dimensional drawings. Such drawings available on request.  
 Contact factory with correct model designation and serial number.  
 All dimensions are expressed in mm.



## Dimensions (mm) - Hydraulic Override

END VIEW REPRESENTATIVE OF ALL CBAX30-M18 MODELS

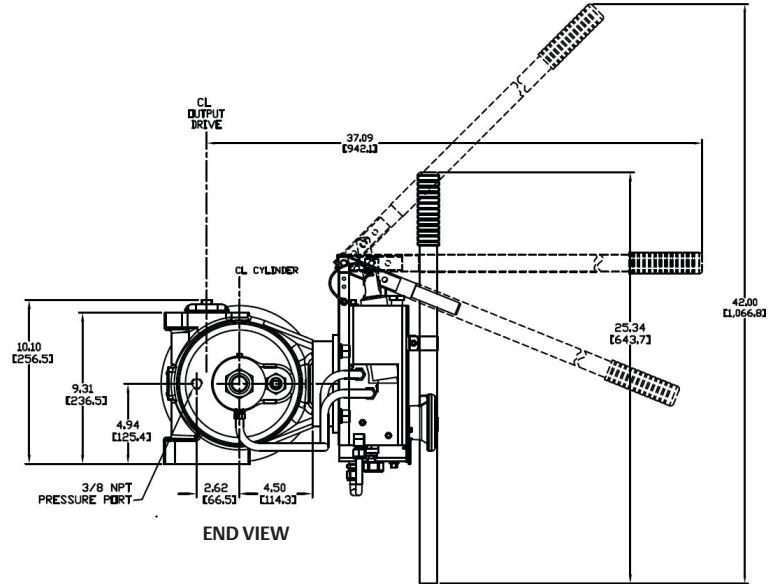

END VIEW REPRESENTATIVE OF ALL CBAX30-M11 MODELS

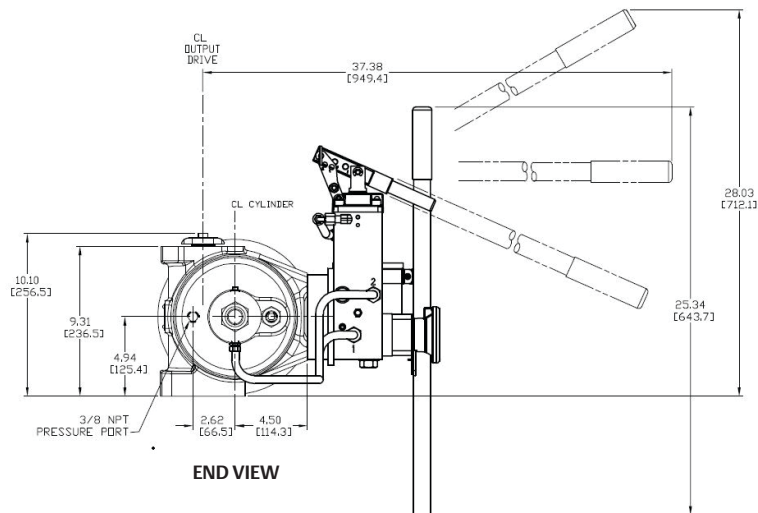

**NOTES:**  
Other dimensions refer to base actuator pages.  
Not Certified dimensional drawings. Such drawings available on request.  
Contact factory with correct model designation and serial number.  
All dimensions are expressed in mm.

**World Area Configuration Centers (WACC) offer sales support, service, inventory and commissioning to our global customers.**

**Choose the WACC or sales office nearest you:**

***NORTH & SOUTH AMERICA***

19200 Northwest Freeway  
Houston TX 77065  
USA  
T +1 281 477 4100

Av. Hollingsworth  
325 Iporanga Sorocaba  
SP 18087-105  
Brazil  
T +55 15 3413 8888

***ASIA PACIFIC***

No. 9 Gul Road  
#01-02 Singapore 629361  
T +65 6777 8211

No. 1 Lai Yuan Road  
Wuqing Development Area  
Tianjin 301700  
P. R. China  
T +86 22 8212 3300

***MIDDLE EAST & AFRICA***

P. O. Box 17033  
Jebel Ali Free Zone  
Dubai  
T +971 4 811 8100

P. O. Box 10305  
Jubail 31961  
Saudi Arabia  
T +966 3 340 8650

24 Angus Crescent  
Longmeadow Business Estate East  
P.O. Box 6908 Greenstone  
1616 Modderfontein Extension 5  
South Africa  
T +27 11 451 3700

***EUROPE***

Holland Fasor 6  
Székesfehérvár 8000  
Hungary  
T +36 22 53 09 50

Strada Biffi 165  
29017 Fiorenzuola d'Arda (PC)  
Italy  
T +39 0523 944 411

For complete list of sales and manufacturing sites, please visit [www.emerson.com/actuationtechnologieslocations](http://www.emerson.com/actuationtechnologieslocations) or contact us at [info.actuationtechnologies@emerson.com](mailto:info.actuationtechnologies@emerson.com)

[www.emerson.com/bettis](http://www.emerson.com/bettis)

VCPDS-13402-EN ©2022, 2021 Emerson. All rights reserved.

The Emerson logo is a trademark and service mark of Emerson Electric Co. Bettis™ is a mark of one of the Emerson family of companies. All other marks are property of their respective owners.

The contents of this publication are presented for informational purposes only, and while every effort has been made to ensure their accuracy, they are not to be construed as warranties or guarantees, express or implied, regarding the products or services described herein or their use or applicability. All sales are governed by our terms and conditions, which are available upon request. We reserve the right to modify or improve the designs or specifications of such products at any time without notice.

**BETTIS™**

