

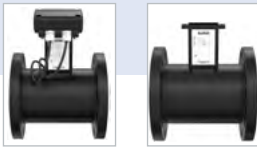





Magnetic inductive sensor with flange

- For connection to a transmitter Type SE58 (with or without display, in compact or remote version) for flow measurement
- Design mainly for use in applications with water
- Flow measurement 25...approx. 75,000 l/min for DN 25...DN 400



Product variants described in the data sheet may differ from the product presentation and description.

Can be combined with

	Type SE58 Version L of the transmitter for electromagnetic-inductive flow sensors	▶
	Type SE58 Version M of the transmitter for electromagnetic-inductive flow sensors	▶
	Type SE58 Version S of the transmitter for electromagnetic-inductive flow sensors	▶

Description du Type

The Type S055 magnetically inductive flow sensor (compact or separate version) is suitable for liquids with a minimum conductivity and for use in applications with requirements in areas of water measurements.

The combination with the dedicated SE58 S transmitter (minimum required conductivity: 20 $\mu\text{S/cm}$) or with the SE58 M or SE58 L transmitters (minimum conductivity required: 5 $\mu\text{S/cm}$) results in a flowmeter with different performance, functions, materials and approvals, with the corresponding suitability for the respective applications depending on the respective requirements.

With the SE58 S you get a compact device, with the SE58 M and SE58 L compact devices or remote versions are created for which the transmitter and sensor are connected by 2 cables up to a maximum length. Standard process connections available for the S055 are flange connections.

Table of contents

1. General Technical Data	3
2. Dimensions	5
2.1. Compact version, PN 16.....	5
2.2. Remote version with junction box, PN 16.....	6
3. Product installation	7
3.1. Installation notes.....	7
3.2. Selection of the nominal diameter	8
4. Product operation	8
4.1. Measuring principle	8
5. Ordering information	9
5.1. Bürkert eShop – Easy ordering and quick delivery.....	9
5.2. Recommendation regarding product selection	9
5.3. Bürkert product filter.....	9
5.4. Ordering chart sensor Type S055	10
5.5. Ordering chart accessories.....	11

1. General technical data

The S055 electromagnetic flow sensor in a compact or remote version is intended for use with transmitter Type SE58, which is available in three versions L, M or S.



Detailed information can be found in the data sheet of the transmitter, see [data sheet Type SE58](#) ▶.

Product properties

Material

Non wetted parts

Sensor housing	Carbon steel painted (stainless steel 304 or 316 on request)
Junction box	Only for remote sensor: painted aluminium (on request: stainless steel 304 (1.4301) raw or polished)

Wetted parts

Lining	PP or ebonite (hard rubber) (PTFE on request)
Electrode	Stainless steel 316L (Alloy C, Titanium, Tantalum, Platinum-rhodium on request)
Seal	<ul style="list-style-type: none"> • FKM (EPDM on request) with PP lining • Without gasket with ebonite (hard rubber) lining (with PTFE lining on request)

Pipe diameter	DN 25...DN 200 (upper DN on request)
Dimensions	Detailed information can be found in chapter “2. Dimensions” on page 5.
Measuring principle	Electromagnetic induction Detailed information can be found in chapter “4.1. Measuring principle” on page 8.
Measuring range	0...0.72 m ³ /h to 0...1130 m ³ /h (upper on request) Detailed information can be found in chapter “5.4. Ordering chart sensor Type S055” on page 10.

Performance data

At reference conditions and according to internal test procedures:

- At room temperature
- Constant flow rate during the test, liquid speed > 1 m/s
- Pressure: > 30 Kpa
- Flow condition: observed inlet and outlet conditions
- Zero point stability: ±0.005 %

Measurement deviation	<p>If used with SE58 transmitter:</p> <ul style="list-style-type: none"> • in compact or remote L version: ≤ ±0.2 % of the measured value for flow velocity > 0.5 m/s • in compact or remote M version: ≤ ±0.8 % of the measured value for flow velocity > 0.5 m/s • in compact S version: ≤ ±0.5 % of the measured value for flow velocity > 0.5 m/s <p>See data sheet Type SE58 ▶</p>
Repeatability	<p>If used with SE58 transmitter:</p> <ul style="list-style-type: none"> • in compact or remote L version: ≤ ±0.1 % of the measured value for flow velocity > 0.5 m/s • in compact or remote M version: ≤ ±0.4 % of the measured value for flow velocity > 0.5 m/s • in compact S version: ≤ ±0.25 % of the measured value for flow velocity > 0.5 m/s <p>See data sheet Type SE58 ▶</p>
Vacuum resistance	200 mbar (2.9 PSI) absolute at 100 °C (212 °F) for PTFE, at 60 °C (140 °F) for PP and at 80 °C (176 °F) for ebonite

Medium data

Fluid temperature	<ul style="list-style-type: none"> • With PP lining used with SE58 transmitter: <ul style="list-style-type: none"> – in compact version: -0...+60 °C (+32...+140 °F) – in remote version: -0...+60 °C (+32...+140 °F) • With ebonite lining used with SE58 transmitter: <ul style="list-style-type: none"> – in compact version: -5...+80 °C (+23...+176 °F) – in remote version: -5...+80 °C (+23...+176 °F) • With PTFE lining (on request) used with SE58 transmitter: <ul style="list-style-type: none"> – in compact version: -20...+100 °C (-4...+212 °F) – in remote version: -20...+110 °C (-4...+230 °F)
-------------------	---

Fluid pressure	<ul style="list-style-type: none"> • PN 16 (232 PSI) with PP or ebonite lining • PN40 on request, only with PTFE lining up to DN 150
----------------	--

Minimum conductivity	5 µS/cm (or 20 µS/cm with demineralised water)
----------------------	--

Process/Port connection & communication

Process connection	Flange EN1092-1, ANSI B16-5, (JIS on request)
--------------------	---

Electrical connection	2 cable glands PG9 (for remote version of the sensor)
-----------------------	---

Approvals and certificates**Directives**

CE directive	The applied standards, which verify conformity with the EU Directives, can be found on the EU Type Examination Certificate and/or the EU Declaration of conformity (if applicable).
Pressure equipment directive	<p>The device is subject to the requirements of the Pressure Equipment Directive 2014/68/EU. Category II device for group 1 and 2 fluids under the following conditions:</p> <ul style="list-style-type: none"> • maximum allowable pressure (PS) ≤ 40 bar • minimum/maximum temperature (TS): -10/+130 °C • within the following limits for liquids of group 2: <ul style="list-style-type: none"> – PN 10 for DN 400...DN 500 – PN 16 for DN 250...DN 300 – PN 25 for DN 200...DN 250 – PN 40 for DN 40...DN 250 • within the following limits for liquids of group 1 with a vapour pressure at the maximum allowable temperature not exceeding 0.5 bar (g); for diameters above DN 25 and PSxDN>2000

Environment and installation

Ambient temperature	According to the used version of SE58 transmitter and its material Detailed information can be found in the data sheet of the transmitter, see data sheet Type SE58 ▶.
Relative air humidity	≤90 %, without condensation
Height above sea level	Max. 2000 m
Operating condition	Continuous
Equipment mobility	Fixed device
Application range	Indoor and outdoor (protect the device against electromagnetic interference, ultraviolet rays and against the effects of climatic conditions)
Degree of protection according to IEC/EN 60529	<p>If use with SE58 transmitter:</p> <ul style="list-style-type: none"> • in compact L and M version: IP67 (IP68 optional) • in compact S version: IP67 (IP68 optional) • in remote L and M version: IP68 <p>See data sheet Type SE58 ▶</p>
Installation category	Category II according to UL/EN 61010-1
Pollution degree	Degree 2 according to UL/EN 61010-1

2. Dimensions

2.1. Compact version, PN 16

Note:

- Detailed information on the dimensions of the SE58 transmitter can be found in **data sheet Type SE58** ▶.
- Dimensions in mm (unless specified differently)

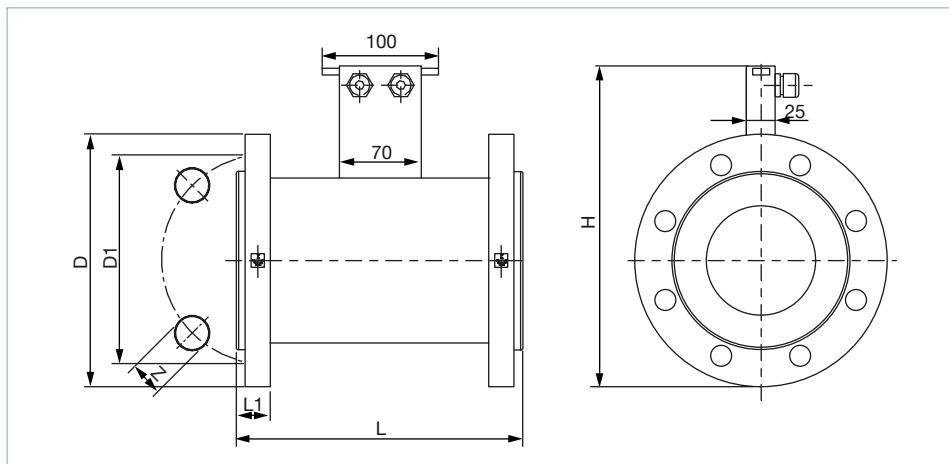

DN	H	L	Standard	L1	Z	D1	D
25	185	200	EN 1092-1	18	4x14	85	115
	182		ANSI 150 RF	16.3	4x15.9	79.4	107.9
32	203	200	EN 1092-1	18	4x18	100	140
	192		ANSI 150 RF	17.9	4x15.9	88.9	117.5
40	213	200	EN 1092-1	18	4x18	110	150
	202		ANSI 150 RF	19.5	4x15.9	98.4	127
50	228	200	EN 1092-1	18	4x18	125	165
	222		ANSI 150 RF	21.1	4x19	120.7	152.4
65	248	200	EN 1092-1	18	4x18	145	185
	245		ANSI 150 RF	24.3	4x19	139.7	177.8
80	263	200	EN 1092-1	20	8x18	160	200
	258		ANSI 150 RF	25.9	4x19	152.4	190.5
100	283	250	EN 1092-1	20	8x18	180	220
	287		ANSI 150 RF	25.9	8x19	190.5	228.6
125	313	250	EN 1092-1	22	8x18	210	250
	315		ANSI 150 RF	25.9	8x22.2	215.9	254
150	344	300	EN 1092-1	22	8x22	240	285
	341		ANSI 150 RF	27.4	8x22.2	241.3	279.4
200	399	350	EN 1092-1	24	12x22	295	340
	401		ANSI 150 RF	30.6	8x22.2	298.5	342.9

DTS 1000471664 EN Version: C Status: RL (released | freigegeben | validé) printed: 10.11.2022

2.2. Remote version with junction box, PN 16

Note:

- Detailed information on the dimensions of the SE58 transmitter can be found in **data sheet Type SE58** ▶.
- Dimensions in mm (unless specified differently)

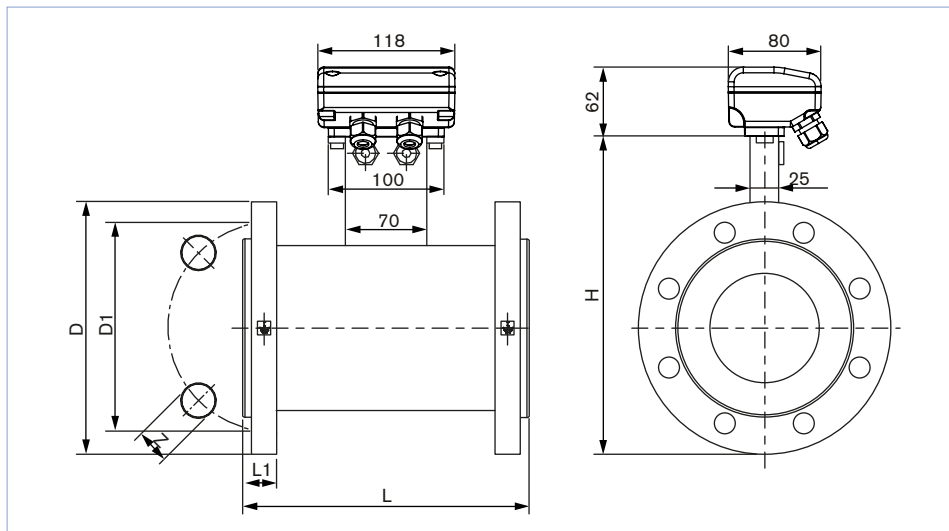

DN	H	L	Standard	L1	Z	D1	D
25	185	200	EN 1092-1	18	4x14	85	115
	182		ANSI 150 RF	16.3	4x15.9	79.4	107.9
32	203	200	EN 1092-1	18	4x18	100	140
	192		ANSI 150 RF	17.9	4x15.9	88.9	117.5
40	213	200	EN 1092-1	18	4x18	110	150
	202		ANSI 150 RF	19.5	4x15.9	98.4	127
50	228	200	EN 1092-1	18	4x18	125	165
	222		ANSI 150 RF	21.1	4x19	120.7	152.4
65	248	200	EN 1092-1	18	4x18	145	185
	245		ANSI 150 RF	24.3	4x19	139.7	177.8
80	263	200	EN 1092-1	20	8x18	160	200
	258		ANSI 150 RF	25.9	4x19	152.4	190.5
100	283	250	EN 1092-1	20	8x18	180	220
	287		ANSI 150 RF	25.9	8x19	190.5	228.6
125	313	250	EN 1092-1	22	8x18	210	250
	315		ANSI 150 RF	25.9	8x22.2	215.9	254
150	344	300	EN 1092-1	22	8x22	240	285
	341		ANSI 150 RF	27.4	8x22.2	241.3	279.4
200	399	350	EN 1092-1	24	12x22	295	340
	401		ANSI 150 RF	30.6	8x22.2	298.5	342.9

DTS 1000471664 EN Version: C Status: RL (released | freigegeben | valide) printed: 10.11.2022

3. Product installation

3.1. Installation notes

Note:

The flow meter is not designed for gas and steam flow measurement.

- During flowmeter operation the pipe must be completely full.
- Observe the upstream and downstream distances.

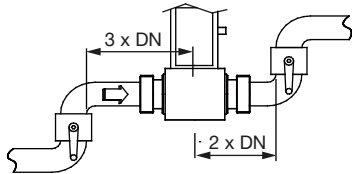

The sensor can be installed into either horizontal or vertical pipes. Mount the sensor in the indicated positions shown below to obtain an accurate flow measurement.

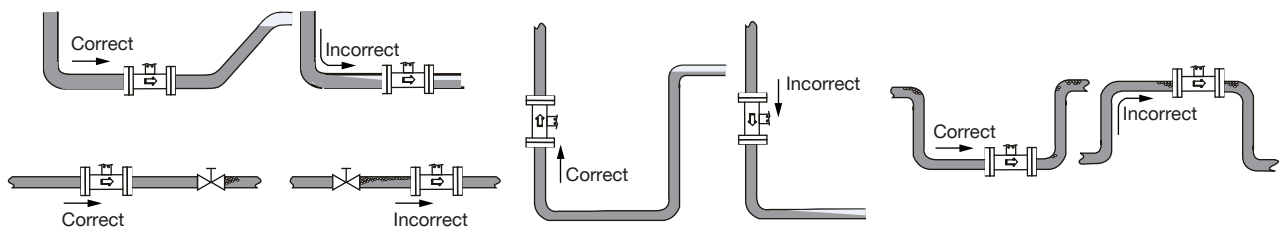

The suitable pipe size can be selected using the nominal pipe size selection chart. See chapter [“3.2. Selection of the nominal diameter”](#) on page 8.

3.2. Selection of the nominal diameter

The graph is used to determine the DN of the pipe appropriate to the application, according to the fluid velocity and the flow rate. On the chart, the intersection of flow rate and flow velocity gives the appropriate diameter.

Example:

- Flow: 100 l/min
- Optimal flow rate: 2...3 m/s

Result: Select a pipe size of DN 32

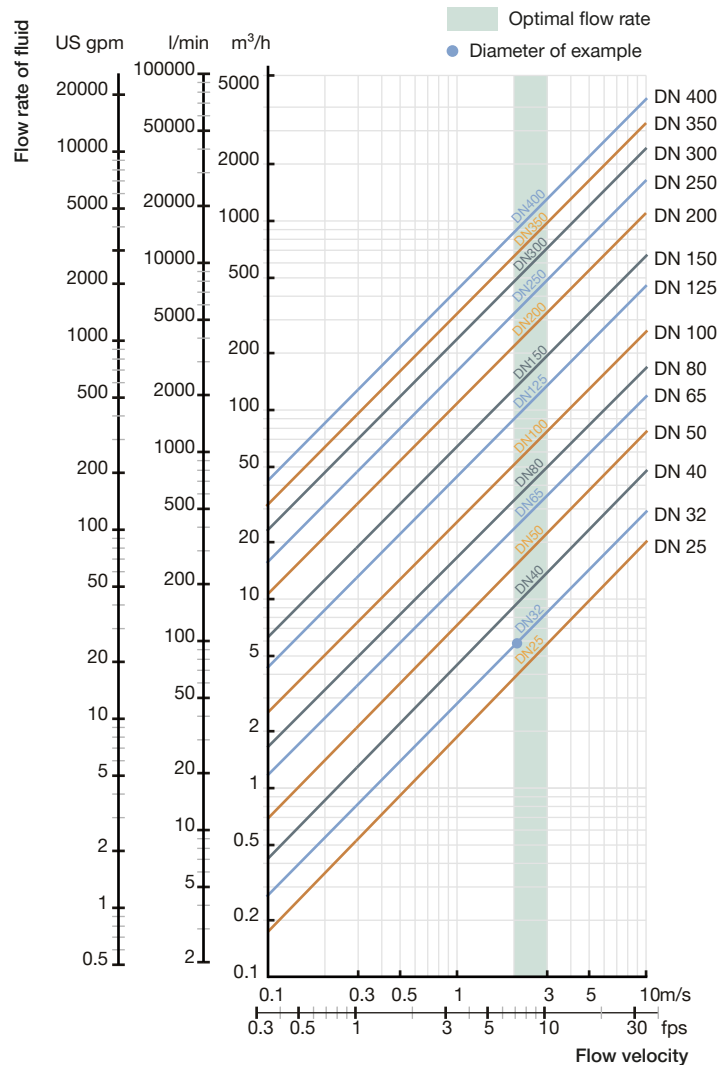

4. Product operation

4.1. Measuring principle

Faraday's law serves as the physical basis for magnetic flow measurement. Magnetic coils are arranged around the pipeline to generate a magnetic field. Conductive liquids flowing through the magnetic field induce a voltage at two opposite metallic electrodes in contact with the medium. These electrodes are used to measure the induced electrical alternating voltage. The signal of sensor S055 must be amplified and processed by transmitter SE58.

Detailed information on the dimensions of the SE58 transmitter can be found in [data sheet Type SE58](#) ▶.

5. Ordering information

5.1. Bürkert eShop – Easy ordering and quick delivery



Bürkert eShop – Easy ordering and fast delivery

You want to find your desired Bürkert product or spare part quickly and order directly? Our online shop is available for you 24/7. Sign up and enjoy all the benefits.

[Order online now](#)

5.2. Recommendation regarding product selection

A complete flowmeter consists of a S055 (compact or remote version) and a SE58 transmitter (compact or remote version).

See [data sheet Type SE58](#) ▶ for more information.

Two different components must be ordered in order to select a complete device. The following information is required:

- **Article no.** of the sensor **Type S055** (Detailed information can be found in chapter [“5.4. Ordering chart sensor Type S055” on page 10](#))
- **Article no.** of the transmitter **Type SE58** (see [data sheet Type SE58](#) ▶ for more information)

5.3. Bürkert product filter



Bürkert product filter – Get quickly to the right product

You want to select products comfortably based on your technical requirements? Use the Bürkert product filter and find suitable articles for your application quickly and easily.

[Try out our product filter](#)

5.4. Ordering chart sensor Type S055

DN [mm]	Process connection	Flow rate range		Housing material	Wetted parts materials			Article no.
		Min. 0...0.4 m³/s	Max. 0...10 m³/s		Electrode ^{1.)}	Seal	Lining	
Sensor Type S055, compact version								
25	EN 1092-1	0...0.72 m³/h	0...18 m³/h	Carbon steel	Stainless steel 316L	FKM	PP	553540
	ANSI 150							554353
32	EN 1092-1	0...1.16 m³/h	0...29 m³/h					553541
	ANSI 150							560047
40	EN 1092-1	0...1.80 m³/h	0...45 m³/h					553542
	ANSI 150							560048
50	EN 1092-1	0...2.88 m³/h	0...72 m³/h					553485
	ANSI 150							554354
65	EN 1092-1	0...4.80 m³/h	0...120 m³/h					553393
	ANSI 150							558785
80	EN 1092-1	0...7.20 m³/h	0...180 m³/h					553394
	ANSI 150							554351
100	EN 1092-1	0...11.20 m³/h	0...280 m³/h	553489				
	ANSI 150			554352				
125	EN 1092-1	0...18.00 m³/h	0...450 m³/h	559318				
	ANSI 150			562955				
150	EN 1092-1	0...25.60 m³/h	0...640 m³/h	557512				
	ANSI 150			561426				
200	EN 1092-1	0...45.20 m³/h	0...1130 m³/h	Carbon steel	Stainless steel 316L	–	Ebonite (hard rubber)	554217
	ANSI 150			560568				
Sensor Type S055, remote version with junction box in painted aluminium and 10 m electrodes and coils cables (included)								
25	EN 1092-1	0...0.72 m³/h	0...18 m³/h	Carbon steel	Stainless steel 316L	FKM	PP	448492
	ANSI 150							559598
32	EN 1092-1	0...1.16 m³/h	0...29 m³/h					448493
	ANSI 150							562958
40	EN 1092-1	0...1.80 m³/h	0...45 m³/h					448494
	ANSI 150							559599
50	EN 1092-1	0...2.88 m³/h	0...72 m³/h					448495
	ANSI 150							562128
65	EN 1092-1	0...4.80 m³/h	0...120 m³/h					448496
	ANSI 150							562959
80	EN 1092-1	0...7.20 m³/h	0...180 m³/h					448497
	ANSI 150							562129
100	EN 1092-1	0...11.20 m³/h	0...280 m³/h	448498				
	ANSI 150			555666				
125	EN 1092-1	0...18.00 m³/h	0...450 m³/h	560144				
	ANSI 150			562956				
150	EN 1092-1	0...25.60 m³/h	0...640 m³/h	554141				
	ANSI 150			561952				
200	EN 1092-1	0...45.20 m³/h	0...1130 m³/h	Carbon steel	Stainless steel 316L	–	Ebonite (hard rubber)	559753
	ANSI 150			562135				

1.) Three electrodes (2 measuring electrodes + 1 ground electrode)

DTS 1000471664 EN Version: C Status: RL (released | freigegeben | valide) printed: 10.11.2022

Further versions on request	
Material <ul style="list-style-type: none"> Seal: EPDM Lining: PTFE Junction box: stainless steel 304 (1.4301) raw or polished Body: stainless steel 304, stainless steel 316L Electrodes: <ul style="list-style-type: none"> Alloy C (2 measuring electrodes + 1 ground electrode) Titanium (2 measuring electrodes + 1 ground electrode) Tantalum (2 measuring electrodes + 1 ground electrode) Platinum-rhodium (2 measuring electrodes + 1 ground electrode) 	Process connection Flange: ANSI 300; JIS 10 K
	Orifice DN > 200 ^{1.)}
	Pressure PN 10, PN 25, PN 40

1.) Ebonite (hard rubber) or PTFE lining material (if PTFE not selected then Ebonite (hard rubber) in standard)

5.5. Ordering chart accessories

Accessories for remote sensor	No.	Description	Article no.
<p>Without junction box</p> <p>With junction box</p>	1	10 m cable for electrodes ^{1.)} For connecting the sensor (version without junction box) Type S051, S054, S055 or S056 to the connecting box of the cable extension kit.	448518
	2	10 m cable for coils ^{1.)} For connecting the sensor (version without junction box) Type S051, S054, S055 or S056 to the connecting box of the cable extension kit.	448519
	3	10 m cable for electrodes ^{1.)} For connecting <ul style="list-style-type: none"> the connecting box of the cable extension kit to the transmitter Type SE58 the sensor (version with junction box) Type S051, S054, S055 or S056 to the transmitter Type SE58 	562851
	4	10 m cable for coils ^{1.)} For connecting <ul style="list-style-type: none"> the connecting box of the cable extension kit to the transmitter Type SE58 the sensor (version with junction box) Type S051, S054, S055 or S056 to the transmitter Type SE58 	562852
	5	Connecting box of the cable extension kit including No. 1 + 2 + 3 + 4 and resin	562853

1.) Other cables length than 10 m on request (for cables length > 20 m a preamplifier could be needed. **Caution, this will result in a price increase!**)

DTS 1000471664 EN Version: C Status: RL (released | freigegeben | valide) printed: 10.11.2022

Bürkert – Close to You

For up-to-date addresses
please visit us at
www.burkert.com

DTS 1000471664 EN Version: C Status: RL (released | freigegeben | validé) printed: 10.11.2022

