





Tek-Bar 3120A



Quick Start Guide

1. Before You Begin

Before installation check the model, specifications, and installation location for the transmitter. Follow the Operating Instruction Manual for detailed installation and other information.

-  Do not remove the transmitter cover in explosive atmospheres when the circuit is alive
-  Before connecting a HART-based communicator in an explosive atmosphere, make sure the instruments in the loop are installed in accordance with intrinsically safe field wiring practices
-  Installation of the device must be carried out by trained, qualified specialists. The specialist must have read and understood these Operating Instructions and must follow the instructions they contain
-  Do not clean or touch diaphragm seals with hard or pointed object
-  When using the measuring device in hazardous areas, installation must comply with the corresponding national standards and regulations and the Safety Instructions or Installation or Control Drawings

2. Unpack

Tek-Bar 3120A Explosion-Proof Gauge Pressure Transmitter

3. Dimensional Drawings

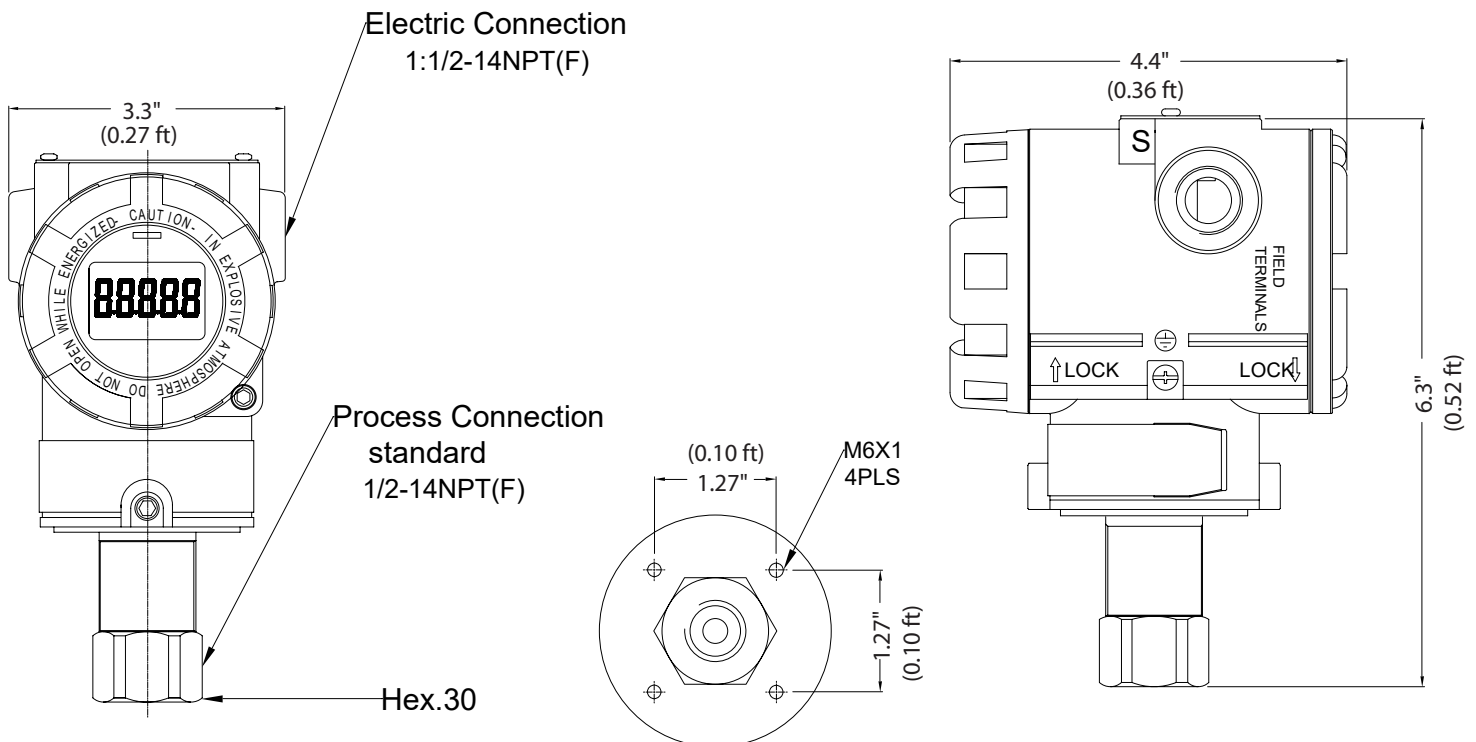

Exploded View

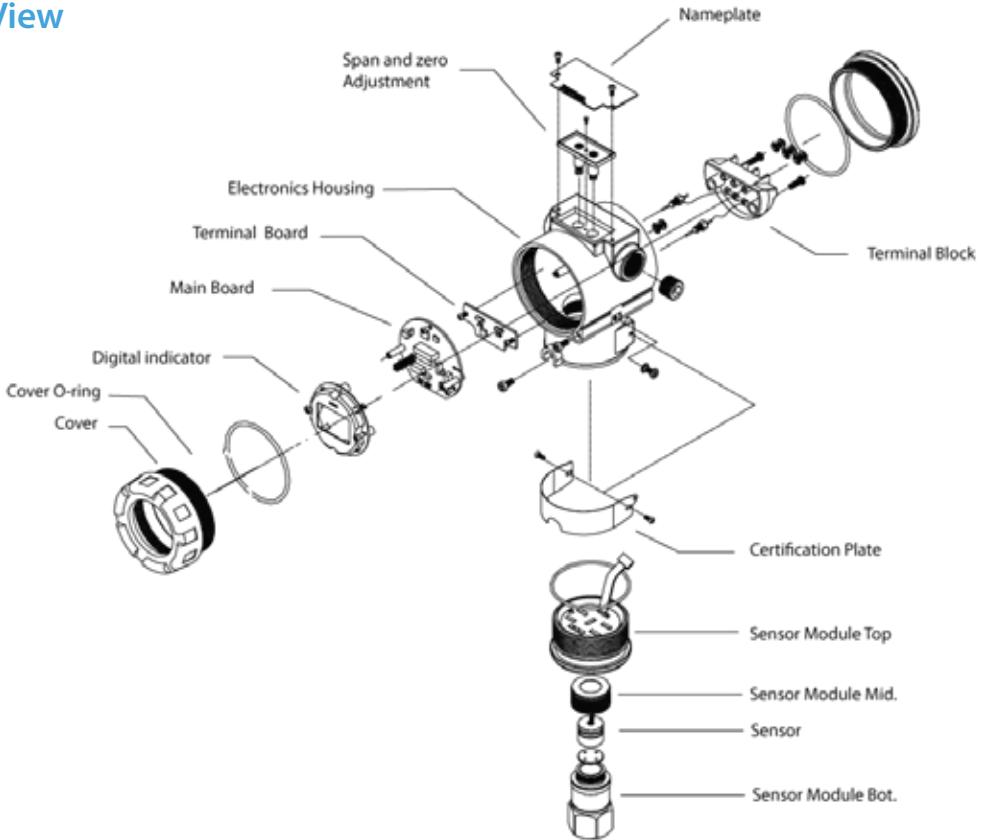

4. Mounting

Vertical Mount Type

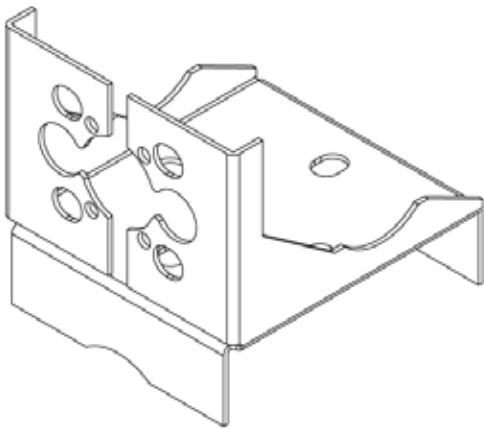

2" Pipe Mounting Bracket
Model: Angle Type

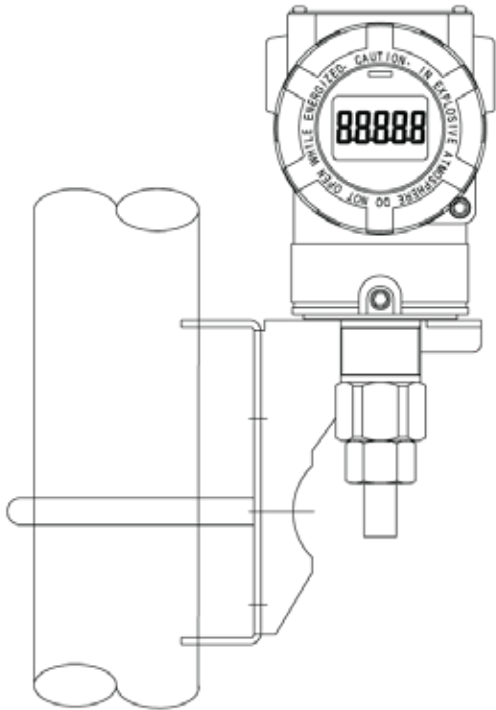

Quick Start Guide

5. Failure Mode Alarm

Fail Mode Selection (Fail High/UP or Low/DOWN) can be configured using the appropriate jumper switch provided on the LCD Module or DIP switches included on the main CPU module. For units provided with a LCD module one can select desired fail-safe mode directly from the jumper switch included in the front display and this setting overrides the DIP settings on the back-end main CPU module. However, in case of blind units select your required DIP switch settings from the DIP switch labelled (2) marked on the main CPU board.

1. Fail Mode Selection Jumper Switch of LCD Module

Level	4-20mA Saturation	4-20mA Alarm
Low/Down	3.9 mA	≤3.75 mA
High/Up	20.8 mA	≥21.75 mA

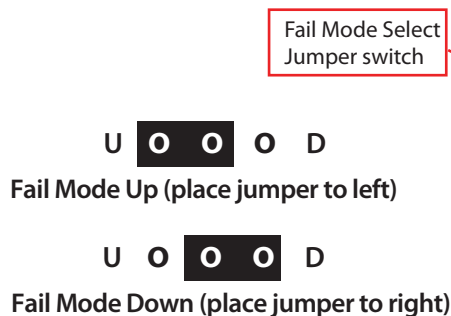

2. Fail Mode Selection DIP Switch on CPU Module

Selected Fail Mode	Jumper status on LCD and Switch(2) on CPU Module		DIP Switch(2) setting on CPU Module
	CPU Module	LCD Module	CPU Module
Fail Down	Down	D	Down
Fail Up	Down	U	Up
	Up	D or U	

6. Display

The local display enables you to read all important parameters directly at the measuring point and configure the device using the function matrix. The LDC display indicates output and diagnostic messages on display. The LCD display features a two-line display with 5-digit. The first line displays measured value and second line displays the engineering units.

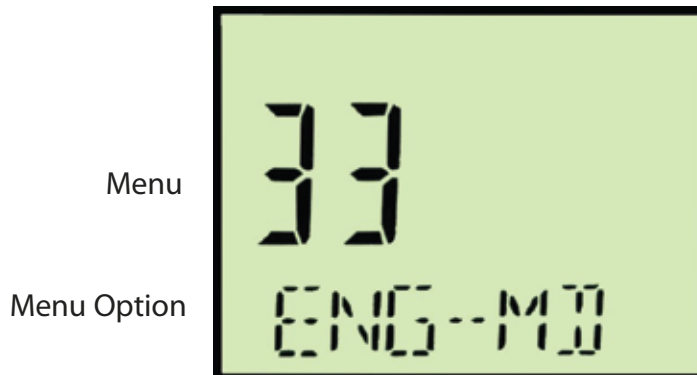

LCD Display Rotation

If the device cannot be operated in a vertical position you can turn the digital display to make it easier to read. To do this, proceed as follows:

Unscrewing the two screws on either side of the LCD screen allows the screen to be rotated 90° clockwise or counter clockwise. An integral indicator can be installed in the following three directions.



Quick Start Guide

7. Power Supply

Connect the positive lead to the terminal marked (+) and the negative lead to the terminal marked (pwr/comm-). Do not connect powered signal wiring to the test terminals. Power could damage the test diode.

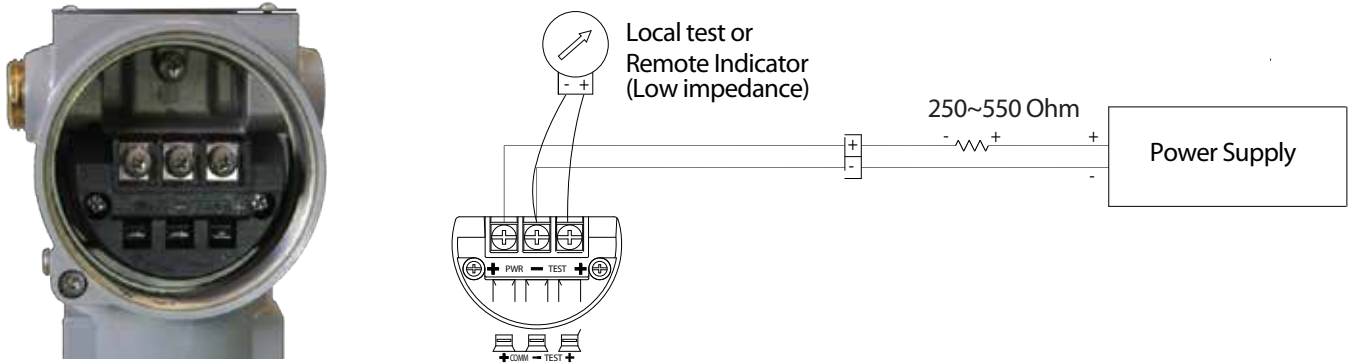

Connection to the HART Handheld Communicator

HART Communicator requires a loop resistance between 250Ω and 550Ω . Transmitter operates on 11.9 to 45 VDC.

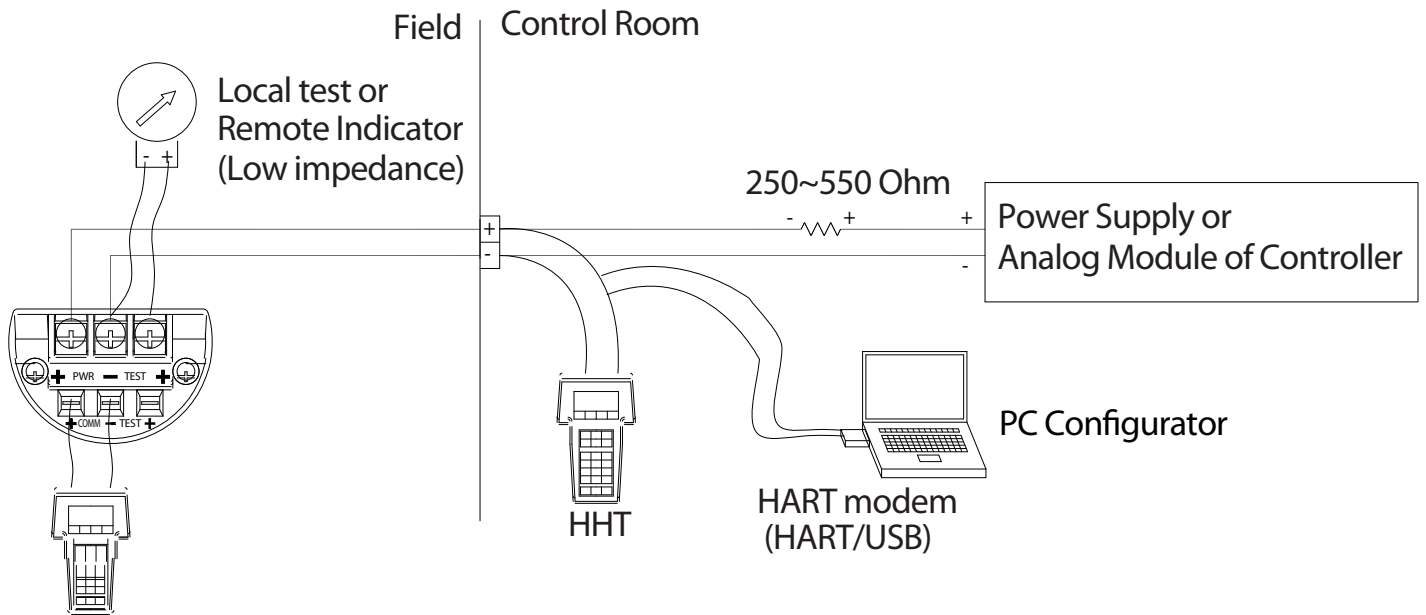

- Note:**
- If LCD display is not available, the HART is used for communication and configuration.
 - Use shielded twisted pairs to yield best results. To ensure proper communication, use 24 AWG or larger wire, and do not exceed 1500 m

8. Grounding

Please provide for proper grounding (earth ground) at designated points (external or internal). There is ground terminal provided on the inside and the outside of the terminal box. Either one of these terminals may be used for grounding the transmitter.

Internal Grounding

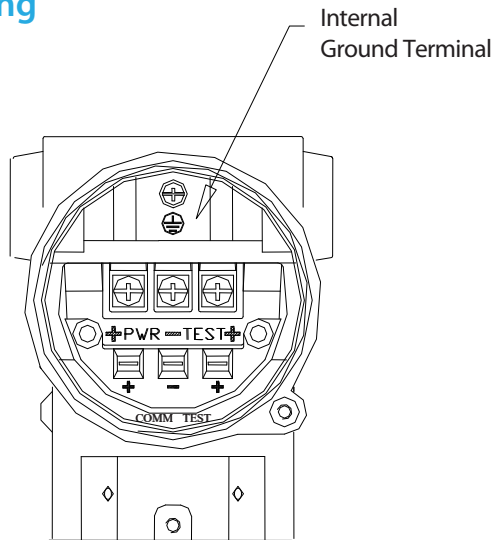

External Grounding

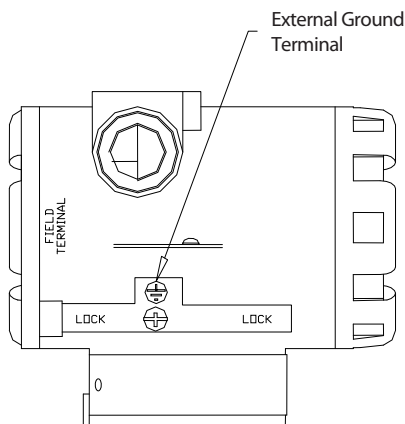

Quick Start Guide

9. Configuration

The top nameplate (right side only) is located in the upper part of the transmitter. Slide the name plate anti-clockwise (slightly until the Zero/Span button is visible and fully accessible.)

Single operation of individual buttons (labelled Zero/Span respectively) will initiate a zero/span configuration process as found in conventional transmitters requiring an external pressure source. However as these are smart transmitters most configuration functions such as Zero Trim, zero adjustment, selecting units, re-ranging (or setting URL/LRL), damping time, display resolution, LCD preference etc. can be done without any external pressure source or HHT.



To access advanced configuration and enter programming menu press both (Zero + Span) buttons simultaneously for 5 seconds. When display reads "Menu" release both push buttons immediately. This will put user into top of main programming menu indicated by message "1-TRIM" on display. To navigate through Main Menu and /or Sub-Menus:

- Use (Zero) Button to scroll down a menu (or sub-menu if active).
For example Pressing/Release (Zero) to scroll down from main menu
1-Trim > 2-Setup > 3-LCD > 1-Trim > 2-Setup etc.
or from an active sub-menu press/release (zero) to scroll down within a sub menu example
21-Units > 22-URL > 23-LRL > 24-Damping > 21- Units > 22-URL etc.
- Use (Span) button to enter into a specific sub menu or data input function.
For example Pressing (Span) button from main menu <1-Trim> will put user into Submenu
"11>Zero Trim". Releasing and Pressing (Span) button again will initiate Zero Trim configuration or Release
and Pressing (Zero) button instead will increment user down to submenu "12>Zero ADJ".
- Within an active sub-menu use of (Span) button also acts as a key to allow user to save changes and exit programming mode.
- For moving back to previous menu press (Zero + Span) button together. During numeric value entry mode use (Zero + Span) button together to save numeric data and exit from programming menu.

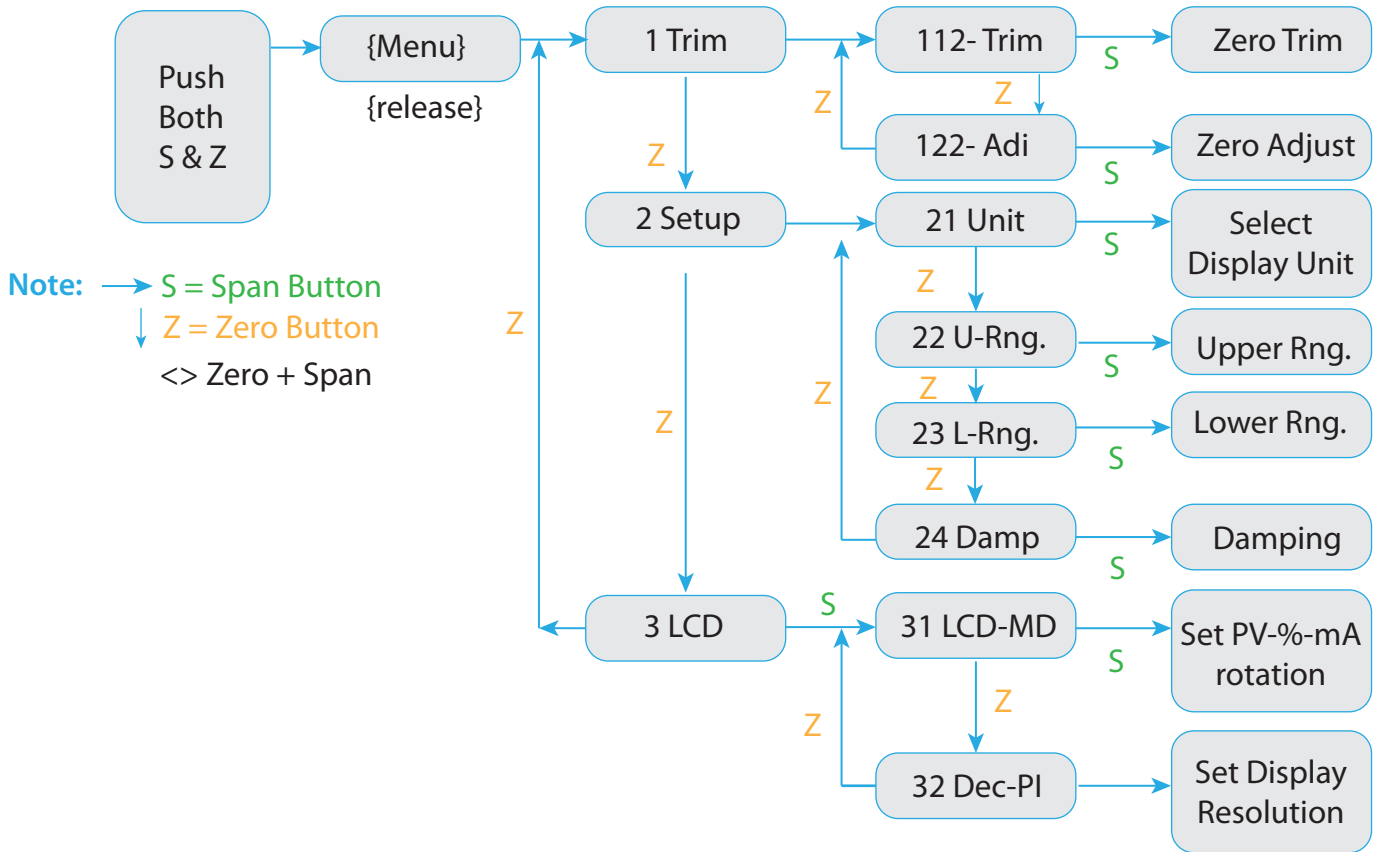

10. Installation

Liquid Flow Measurement

- Place the taps to the side of the line to prevent sediment deposits on the transmitters process isolators
- Mount the transmitter beside or below the taps so gases can vent into the process line
- Mount drain/vent the valve upward to allow gases to vent

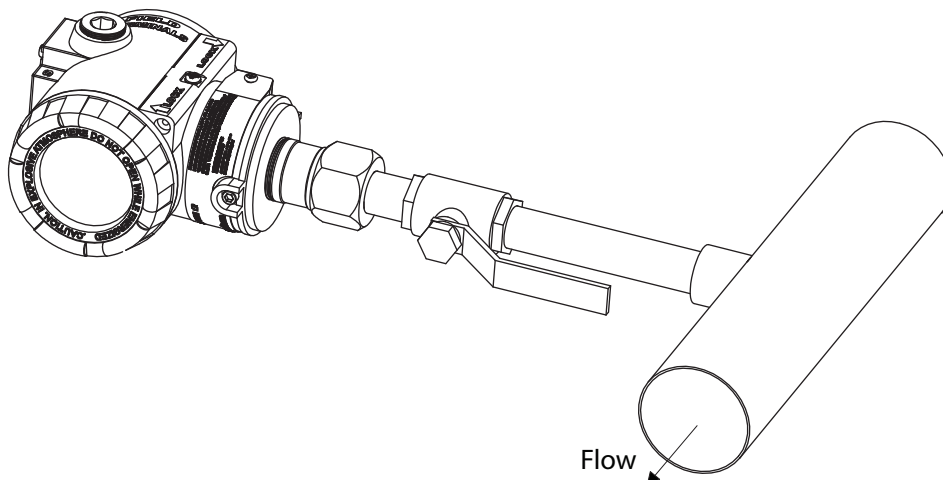

Quick Start Guide

Gas Flow Measurement

- Place taps in the top or side of the line
- Mount the transmitter beside or above the taps so liquid will drain into the process line

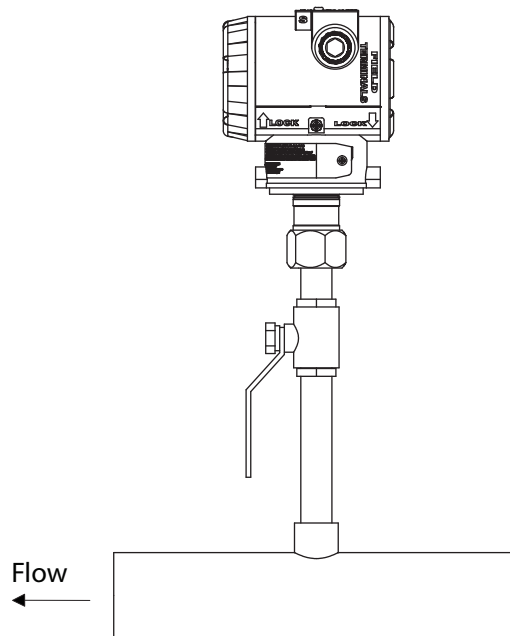

Steam Flow Measurement

- Place taps to the side of the line
- Mount the transmitter below the taps to ensure that the impulse piping will stay filled with condensate
- In steam service above 250°F (121°C), fill impulse lines with water to prevent the steam from contacting the transmitter directly and to ensure accurate measurement at start-up

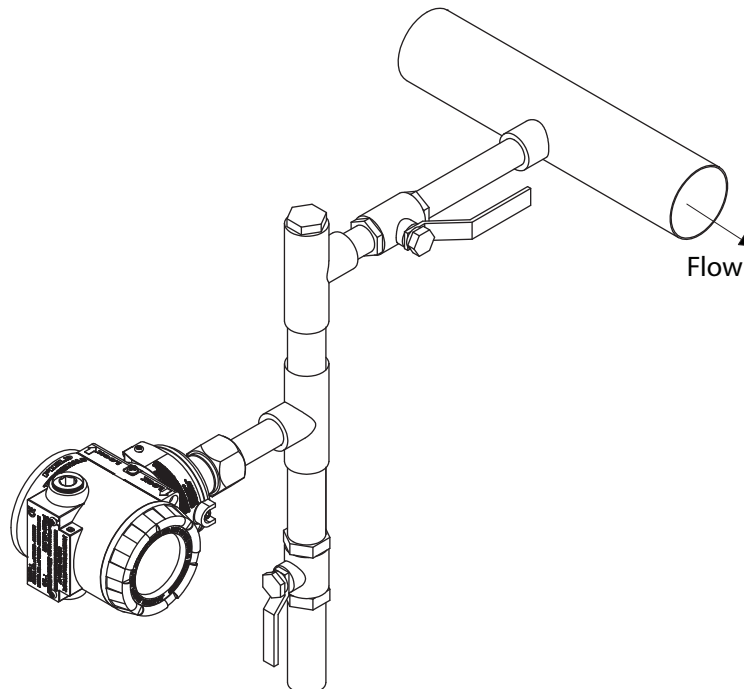

Note: For steam or other elevated temperature services, it is important that temperatures at the process connection do not exceed the transmitters process temperature limits.

11. LCD Screen Display Error Codes

Message	Description	Remarks
ADJ-U	Set value outside of upper limits during Zero Adj function.	Check limits
ADJ-L	Set value outside of upper limits during Zero Adj function.	Check limits
ZERO	Initial message when activating Zero push button	Apply zero input
SPAN	Initial message when activating Span push button	Apply span input
BT-ERR	Button input Sequence error.	Check key seq
P-LOCK	Write Protect Lock on	Check Jumper
ZT-ERR	Setting Limit (10%) Error when Zero Trim	Redo Zero Trim
-TR-	Zero Trim Done	Successful Trim.
ZR-ERR	Set value outside of upper limits during Zero Trim	Check Limits
SP-ERR	Set value outside of upper limits during Span Trim	Check Limits
-ZR-	Zero/LRL configuration with external PV initiated	LRL set up initiated
-SP-	SpanURL configuration with external PV initiated	URL setup initiated
-ZA-	Zero Adjustment done	Z-Adj accepted
-DONE-	Setting Done using button	Changes accepted
RNGOVR	Over range	Check Limits
LCD_OV	Over range for LCD display	Check limits
SCD-ER	Sensor Code Error	Check Sensor
F-RST	Flash Setting Data Reset	Reboot
F-LOCK	While Flash Setting Data Reset, Protect Locked	Write Protect on
F-FAIL	Flash Setting Data Reset Failure	Initialize failed
-FR-	Flash Reset Done	Initialize completed
A-RST	Analog EEPROM Initializing Start	Initialize initiated
A-STOR	Analog EEPROM Whole Write	Write initiated
A-FAIL	Analog EEPROM Whole Write Failure	Write fail
-AC-	Analog EEPROM Whole Write Done	Write completed
S-FL	Sensor Failure	Check sensor input
S-OP	Sensor PV exceed MWP	Check limits
AEP-RF	Check sum error in EEPROM during read sequence	Reboot
AEP-WF	Check sum error in EEPROM during write sequence	Reboot
TS-FL	Temperature sensor failure	Replace
EOSC	Sensor Element defective	Replace
FAVE	Flash Access Violation	Reboot



796 Tek Drive
Crystal Lake, IL 60014
USA

Tel: +1 847 857 6076, +1 847 655 7428

Fax: +1 847 655 6147

Email: tektrol@tek-trol.com

www.tek-trol.com