



**Kamvalok®**  
Dry Disconnect Coupler

## KAMVALOK® DRY DISCONNECT COUPLINGS

Installation, Operation &  
Maintenance (IOM) Manual



## Contents

Kamvalok® Ordering Guide .....	3
Kamvalok® Design Parameters .....	3 - 4
Kamvalok® Seal Options .....	5
Kamvalok® Installation Preparations.....	5
Kamvalok® Maintenance.....	5
Kamvalok® Detailed Disassembly.....	6
Kamvalok® Detailed Rebuild .....	7 - 9
Kamvalok® Testing After Servicing.....	9

# Kamvalok® Dry Disconnect Couplings

OPW Kamvalok® Dry Disconnect Couplings are considered the standard of the industry. Used at liquid-transfer points where product loss could occur, OPW Kamvaloks provide a reliable solution to prevent spillage during connection or disconnection.

## Benefits

### Spill Protection

Helps to reduce the hazards involved in the connection/disconnection process for transferring hazardous materials.

### Provides Total Closed-Loop Loading Capabilities

Keeps hazardous liquids and vapors in-line and out of the environment.

### Dual Protection

Poppeted seal cylinder with snap-on nose seal provides automatic closure from both directions – the coupler and the adaptor – to prevent accidental spills. Nose seal can be easily replaced without need for a new seal cylinder.

### Autolok™ Locking Arms

Provides added protection with an automatic locking mechanism signaled by a positive click. Release requires only an easy tug on the lock release.

### SST Locking Lever Assembly

Locks in position to prevent accidental opening or closing of valve.

### Ease of Use

Simple connection and disconnection design provides for smooth-and-easy operation.



**1700DL**  
Dry Disconnect Couplings

## Ordering Guide

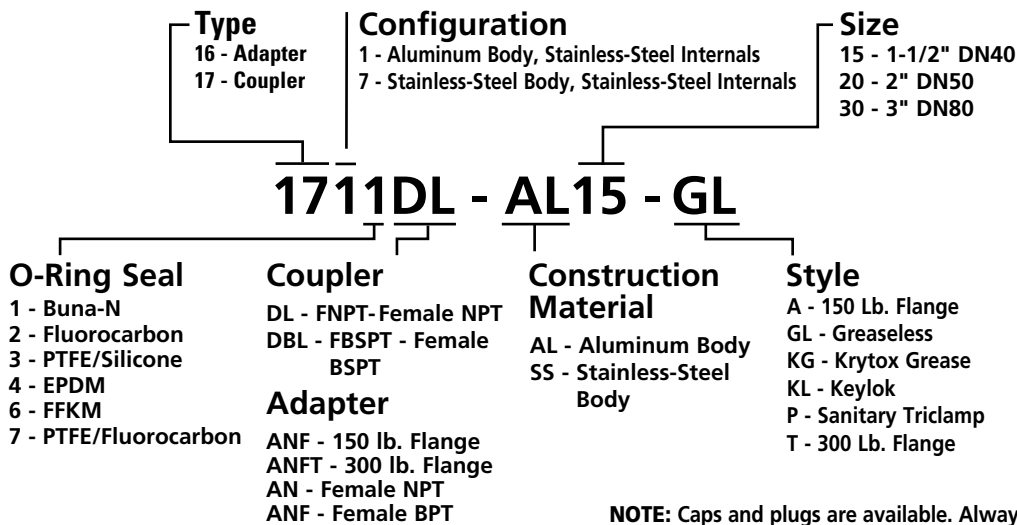

**NOTE:** Caps and plugs are available. Always order the next size up for all plugs/caps. Example: a 1 1/2" Kamvalok requires a 2" cap/plug

## Design Parameters

Design Standard	Size	ASME B31.3	ASME B31.3
Max. Design Temp	ALL	See Material Section	See Material Section
Min. Design Temp	ALL	See Material Section	See Material Section
Max. Working Pressure	1-1/2"	15 Bar	210 psi
	2"	10.5 Bar	150 psi
	3"	8.5 Bar	120 psi

## Design Parameters

Materials	Aluminum (250°F/121°C Max Temp)	SST (see seal chart)
Body, Poppet	A356-T6 ASTM B-26	ASTM A351 CF3M 316L SST
Cam Arms	ASTM A351 CF8M 316 SST	ASTM A351 CF8M 316 SST
Seal Cylinder	6061-T6	A351 CD4MCU Duplex SST
Shaft	ASTM A479 Ferralium 255 SST	ASTM A479 Ferralium 255 SST
Seals	See Chart	See Chart
Poppet Link	A351 CD4MCU Duplex SST	A351 CD4MCU Duplex SST
Shaft Link	A351 CD4MCU Duplex SST	A351 CD4MCU Duplex SST

Seal Options/Kits	Material	1 1/2"	2"	3"	Temperature Rating
Buna-N	AL	1711RKL-0015	1711RKL-0020	1711RKL-0030	-20°F – 212°F
	SST	1771RKL-0015	1771RKL-0020	1771RKL-0030	(-29°C – 100°C)
Fluorocarbon	AL	1712RKL-0015	1712RKL-0020	1712RKL-0030	-20°F – 400°F
	SST	1772RKL-0015	1772RKL-0020	1772RKL-0030	(-29°C – 204°C)
PTFE/Silicone	AL	1713RKL-0015	1713RKL-0020	1713RKL-0030	-15°F – 400°F
	SST	1773RKL-0015	1773RKL-0020	1773RKL-0030	(-26°C – 204°C)
EPDM	AL	1714RKL-0015	1714RKL-0020	1714RKL-0030	-50°F – 250°F
	SST	1774RKL-0015	1774RKL-0020	1774RKL-0030	(-46°C – 121°C)
FFKM	AL	1716RKL-0015	1716RKL-0020	1716RKL-0030	-15°F – 400°F
	SST	1776RKL-0015	1776RKL-0020	1776RKL-0030	(-26°C – 204°C)
PTFE/Fluorocarbon	AL	1717RKL-0015	1717RKL-0020	1717RKL-0030	-15°F – 400°F
	SST	1777RKL-0015	1777RKL-0020	1777RKL-0030	(-26°C – 204°C)

## Part Numbers

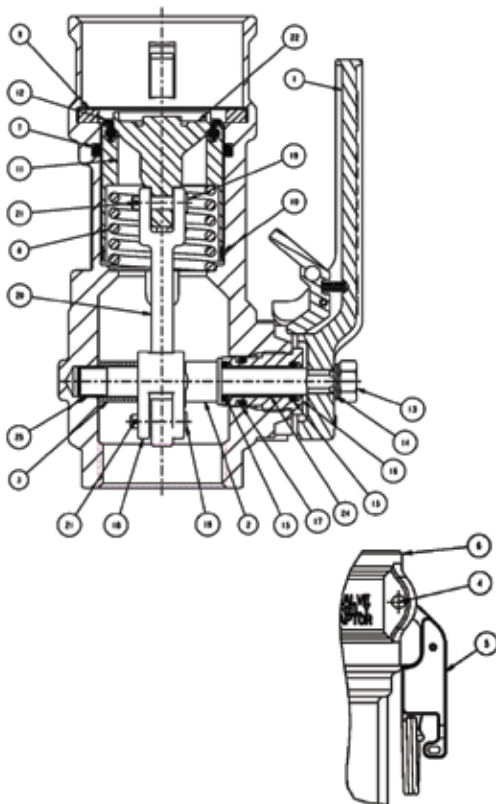

#	Description	Qty	1-1/2"	2"	3"	RK
1	LEVER ASSEMBLY	1	H32040	H32040	H32040	
2	SHAFT	1	C21119RE	C21123RE	C21112RE	
3	SPACER	1	H32031RE	H32030RE	H32032RE	
4	GROOVE PIN, CAM ARM	2	H20141M	H20141M	H20144M	
5	AUTOLOK™ ARM ASSEMBLY	1	733ARK-SS20	733ARK-SS20	733ARK-SS30-PADDLE	
6	BODY	1	C21120A (EW)	C21128A (EW)	C21113A (EW)	
7	O-RING, MAIN SEAL	1	See Seal Options	See Seal Options	See Seal Options	+
8	SPRING	1	H06128M	H04328M	H10352M	
9	GASKET	1	See Seal Options	See Seal Options	See Seal Options	+
10	GUIDE, SEAL CYLINDER	1	H31539M	H31540M	H31541M	+
11	SEAL CYLINDER	1	H31542A (EW)	H31543A (EW)	H31544A (EW)	
12	NOSE SEAL	1	See Seal Options	See Seal Options	See Seal Options	+
13	NUT, SHAFT	1	H32111M	H32111M	H32111M	
14	LOCK WASHER, SHAFT	1	H31920M	H31920M	H31920M	
15	O-RING, SHAFT	2	See Seal Options	See Seal Options	See Seal Options	+
16	STUFFINGBOX	1	C20812RE	C20812RE	C20812RE	
17	O-RING, STUFFINGBOX	1	See Seal Options	See Seal Options	See Seal Options	+
18	SHAFT LINK	1	9C21118EW	9C21125EW	9C21111EW	
19	CLEVIS PIN	2	H31692M	H31692M	H31688M	
20	POPPET LINK	1	9C21117EW	9C21124EW	9C21110EW	
21	COTTER PIN	2	H04981M	H04981M	H04981M	+
22	POPPET	1	C21121A (EW)	C21129A (EW)	C21115A (EW)	
23*	GUIDEBEARING	1	N/A	N/A	H32118M	+
24	SLEEVE BEARING	1	H32163M	H32163M	H32163M	+
25	BUSHING	1	H32226M	H32226M	H32226M	+

NOTE: (EW) Replaces A for SST Fittings  
\*NOTE: Not shown

+ Items included in repair kits

## Seals

1 ½"	O-Ring, Main Seal	Gasket	Nose Seal	O-Ring, Shaft	O-Ring, Stuffingbox
Buna-N	H03051M	H20544M	H31527M	H20129M	H31705M
Fluorocarbon	H03070M	H00973M	H31530M	H20175M	H31706M
PTFE/Silicone	H20184M	H07904M	H31536M	H33153M	H33154M
EPDM	H03596M	H20536M	H31533M	H20176M	H31707M
FFKM	H33190M	H33251M	H31536M	H33153M	H33154M
PTFE/Fluorocarbon	H31198M	H31116M	H31536M	H33153M	H33154M
2"	O-Ring, Main Seal	Gasket	Nose Seal	O-Ring, Shaft	O-Ring, Stuffingbox
Buna-N	H06223M	H20545M	H31528M	H20129M	H31705M
Fluorocarbon	H31865M	H00974M	H31531M	H20175M	H31706M
PTFE/Silicone	H20185M	H07905M	H31537M	H33153M	H33154M
EPDM	H06142M	H20537M	H31534M	H20176M	H31707M
FFKM	H33191M	H33252M	H31537M	H33153M	H33154M
PTFE/Fluorocarbon	H52268M	H31118M	H31537M	H33153M	H33154M
3"	O-Ring, Main Seal	Gasket	Nose Seal	O-Ring, Shaft	O-Ring, Stuffingbox
Buna-N	H05152M	H32180M	H31529M	H20129M	H31705M
Fluorocarbon	H31841M	H32181M	H31532M	H20175M	H31706M
PTFE/Silicone	H20186M	H31562M	H31538M	H33153M	H33154M
EPDM	H10209M	H20266M	H31535M	H20176M	H31707M
Chemraz 505	H20715M	H20714M	H31538M	H20522M	H31708M
FFKM	H33197M	H33253M	H31538M	H33153M	H33154M
PTFE/Fluorocarbon	H31192M	H20845M	H31538M	H33153M	H33154M

## Installation Preparations



**WARNING:** Read and understand these instructions before starting installation or dismantling:

- Coupler to be used for its designated purpose only
- Local regulations for (un)loading must be followed at all times
- Product flow may result in static electricity; grounding of equipment is required
- OPW instructions must be followed for installation or dismantling at all times
- Make sure to use adequate personal protection at all times during operation
- Secure whatever device coupler will be mounted to (e.g. loading arm, hose, etc.)
- Thread coupler onto pipe (use proper thread sealant)

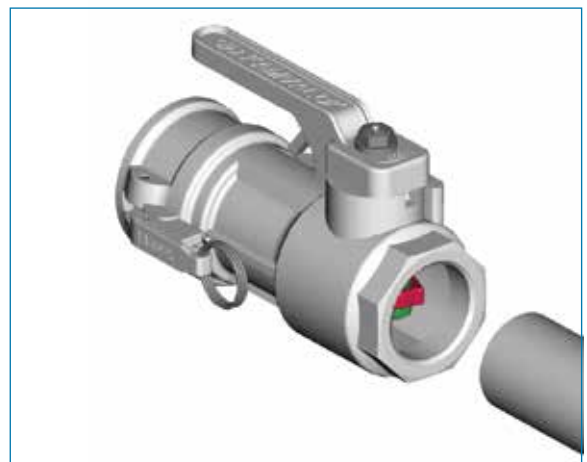

## Maintenance



**ATTENTION:** The same risks and procedures as initial installation apply.

### Consider the following when servicing the coupler:

- When coupler is over-pressurized, it must be inspected thoroughly
- After maintenance is performed, it must be tested before the next use (see Testing After Servicing)

- Recommended periodic inspection (every 3 months) for leakages in shaft, gasket and poppet area (especially with toxic or hazardous media)
- Maintenance must be performed by qualified personnel
- Periodic maintenance (once a year) is recommended according to the maintenance instructions
- In case of (parts of) couplers being returned, the initiator must provide information about the media that have been in contact with (parts of) the coupler
- During maintenance, (partial) dismantling could be necessary; the same risks and procedures apply



## Detailed Disassembly (for seal replacement)

**Recommended Tools:** Adaptor body of OPW Kamvalok® Adaptor, Flat Head Screwdriver, 17mm and 1-1/4" Driver and Torque Wrench



**DISMANTLING WARNING:** Verify what kind of medium is loaded with this coupler (read the manuals provided). When the medium is nuclear, hazardous or toxic, one is obligated to clean parts with the help of specialized personnel, companies or governments.

### Step 1:

- Remove coupler from piping or hose
- Install adaptor and close Autolok™ arms
- Depress release latch and rotate lever only part of the way
- Do not rotate the lever into the fully opened position
- The adaptor is only in place to take the pressure off of the poppet



**WARNING:** With the release latch depressed, the operating lever is unlocked and can rotate. Do not unlock or apply pressure to the lever unless you are trying to open the valve. Use caution when working around the lever when the system is under pressure. Once the lever starts moving, pressure can cause it to rotate violently. Under pressure, poppet will cause lever to rotate violently, if not restrained.

### Step 2:

- Remove shaft nut and lock washer from top of lever assembly
- Remove lever assembly from shaft
- Unthread stuffingbox and pull out shaft
- Pull stuffingbox off of shaft and remove the three O-rings and bearing sleeve from it
- Remove spacer from the shaft
- Remove bushing from coupler body



**WARNING:** Use caution when performing this next step.

### Step 3:

- While pressing the adaptor into the body, release the Autolok™ arms
- Slowly allow the adaptor, poppet and seal cylinder assembly to spring out of the body
- Once all spring pressure is relieved, you can remove the adaptor
- Remove the poppet assembly, followed by the seal cylinder and spring

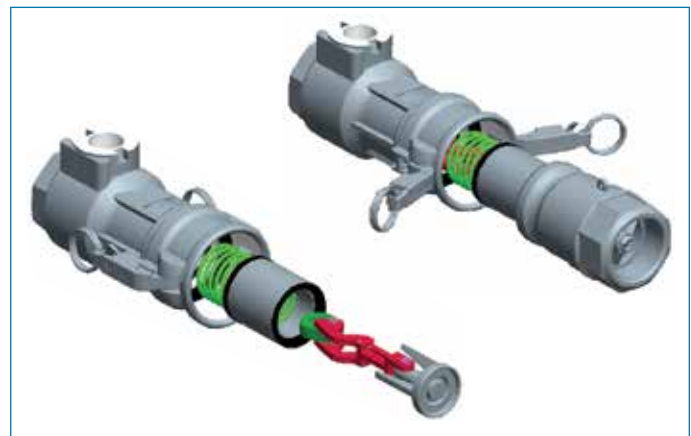

### Step 4:

- Remove the seals from the seal cylinder
- Remove the seals from inside the coupler body
- Be careful not to scratch the sealing surfaces of the coupler body

**Note:** Couplers/Seal Kits purchased after October 2016 will have Nose Seal permanently bonded to Cylinder. Bonded Nose Seal/Cylinder will be included in all Seal Kits.



### Disassembly Complete:

- Clean and inspect all sealing surfaces after removing seals
- Install new seals and reassemble coupler

## Detailed Rebuild

### Step 1:

- Lubricate O-rings with proper grease
- Insert sleeve bearing into stuffingbox
- Lubricate stuffingbox threads
- Fit new O-rings into the grooves in the stuffingbox

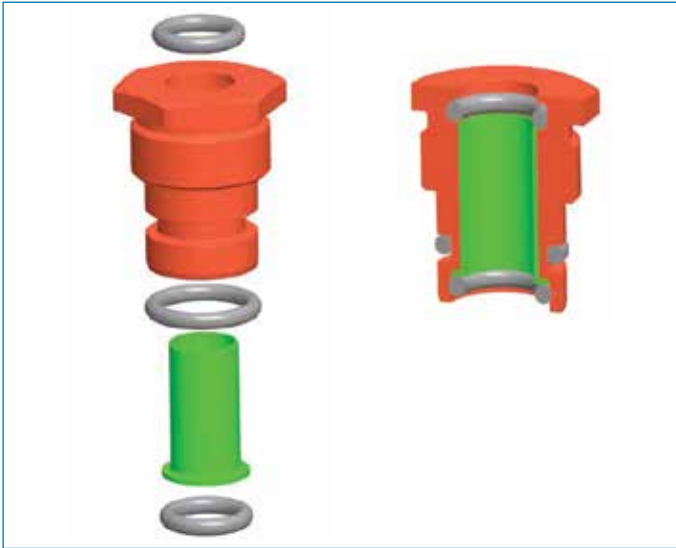

### Step 2:

- Carefully fit nose seal into seal cylinder and slightly expand sleeve bearing and fit into lubricated outer groove on seal cylinder
- Run finger over inside mating surface between nose seal and body to check for any uneven seating. If any raised edges exist, remove nose seal and re-seat more evenly.

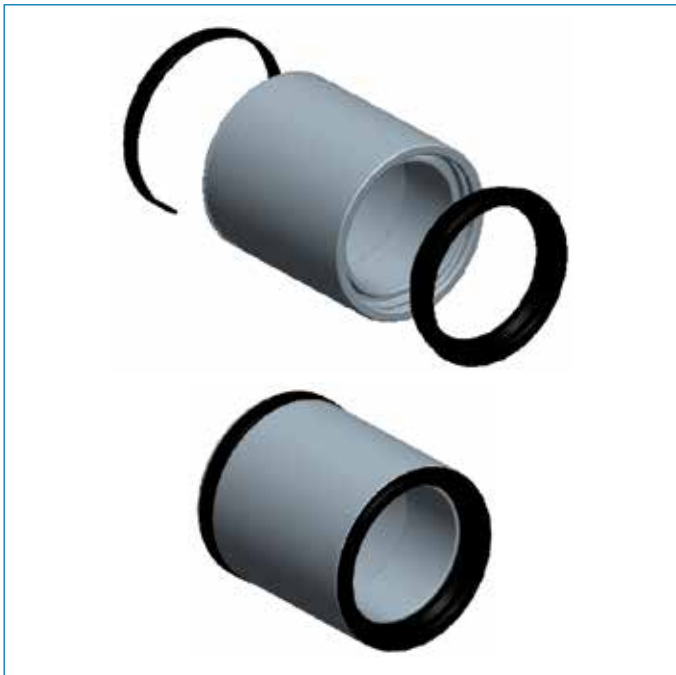

### Step 3:

- Fit O-ring and gasket into body
- Gasket should be compressed slightly and allowed to spring into its groove

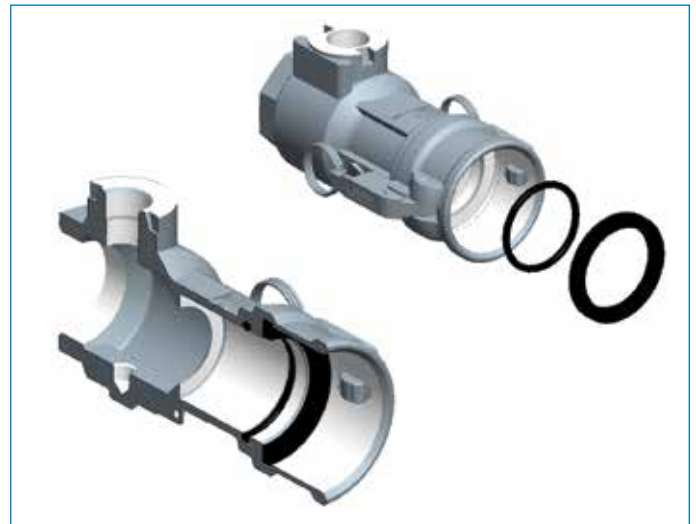

### Step 4:

- With coupler body in a vertical position, insert cylinder spring and seal cylinder using the adaptor body to compress the spring and push all components into the body
- Use caution not to disturb the O-ring already installed in the body when working the seal cylinder into the opening
- Open the Autolok™ arms to allow the adaptor to fully seat in the coupler body
- Once the adaptor is fully seated, lock adaptor into body by closing Autolok™ handles



## Detailed Rebuild

### Step 5:

- Insert poppet linkage assembly through adaptor with cast "dots" on linkage components facing up toward stuffingbox area of coupler body

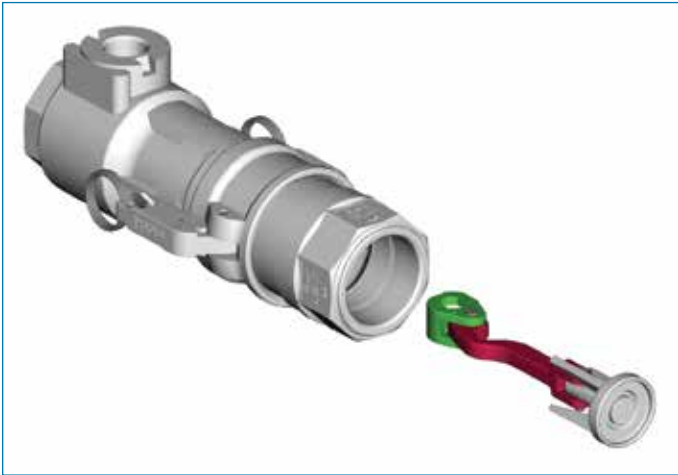

### Step 6:

- Insert bushing spacer through threaded end of the coupler
- Insert shaft through stuffingbox hole in coupler body
- Insert shaft through shaft link, aligning flats on shaft with flats on shaft link
- Insert shaft through spacer and into bushing in bottom of coupler body
- When installed, the shaft and poppet linkage assembly should be oriented as shown

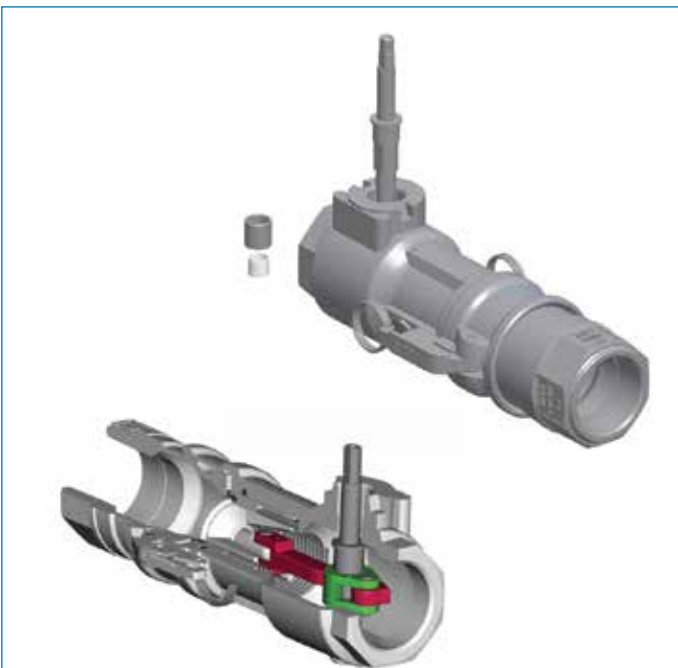

### Step 7:

- Turn the shaft 90 degrees from the closed position to relieve the spring pressure on the linkage
- Install stuffingbox over shaft and thread down with a wrench until it is tight
- Using a torque wrench, tighten the stuffingbox to 960 inch-pounds (108 Newton-meter)
- Remove the adaptor from the coupler



### Step 8:

- With the poppet in the outward position, install the handle as shown
- Secure the lever by threading the shaft nut with lock washer on the shaft
- Tighten the shaft nut to a torque of 290 inch-pounds (33 Newton-meter)

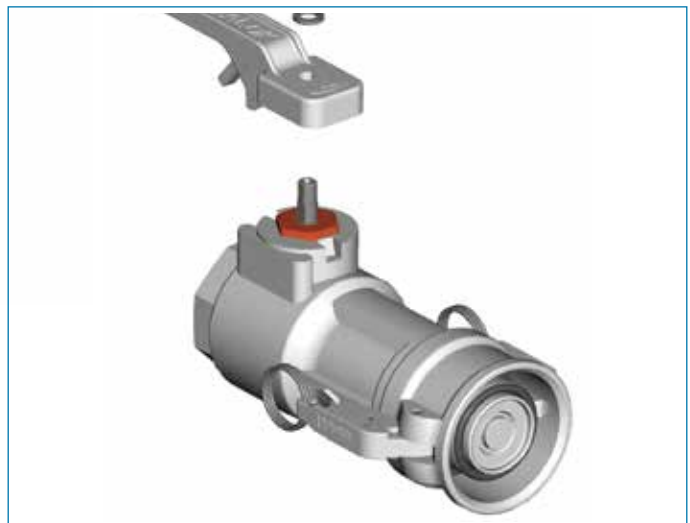



## Step 9:

- Rotate the lever assembly into the closed position
- Assembly complete. Reattach coupler to piping or hose.

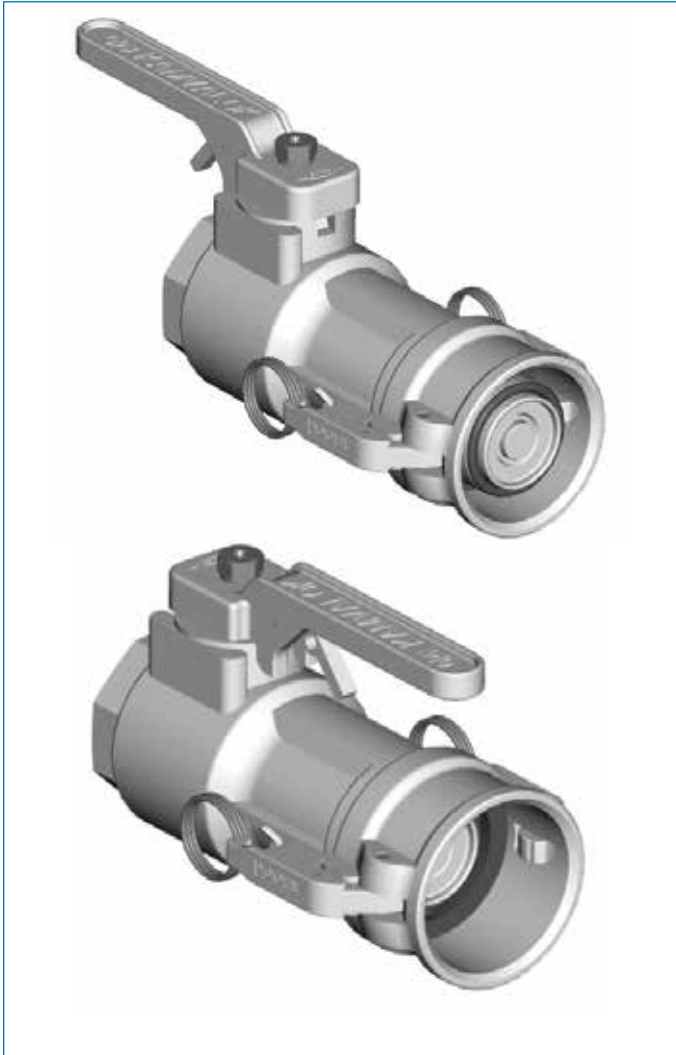

## Testing After Servicing:

- When servicing has occurred and parts have been replaced, it is necessary to test the coupler for safe and secure use.
- Open Autolok™ handles, and bring coupler and adaptor together. Once fully seated, close the Autolok™ handles.

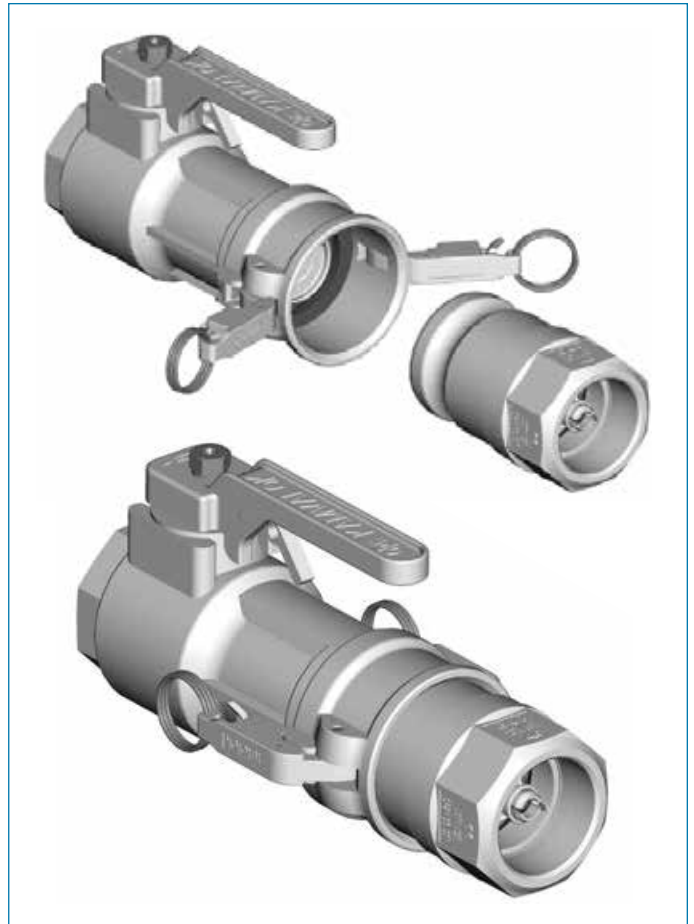

**WARNING**

**Failure to follow these warnings could result in serious personal injury, property damage or product failure.**

- 1) Do not attempt any maintenance service while the equipment is in operation. System pressure must be relieved and the product drained before attempting any service on the unit. The line must be locked out while service is in progress. Proper thermal relief must be provided at all times while equipment is in service.
- 2) OPW products do not eliminate possible exposure to hazardous substances. The conditions of handling and use are beyond our control, and we make no guarantee and assume no liability for damages or injuries related to the use of our products. Follow the safety precautions outlined in the Material Safety Data Sheets for the material being used. It is the responsibility of the user to comply with all federal, state and local regulations. Always employ proper safety precautions and handling techniques.
- 3) Proper seal and wetted material part selection is critical for safe operation. To ensure maximum life for the service intended, use only those materials compatible with the fluids being handled. Please note material being supplied and make certain that it is suited for the intended service.

# ENGINEERING | WHAT'S NEXT



NOTE: All information subject to engineering and/or other changes. All trade names are copyrighted. Patents Pending. ©2022 OPW Fueling Components. ©2022 Delaware Capital Formation, Inc. All Rights Reserved. DOVER and the DOVER logo are registered trademarks of Delaware Capital Formation, Inc., a wholly-owned subsidiary of Dover Corporation.

[www.opw-es.com](http://www.opw-es.com) | 9393 Princeton-Glendale Road | Hamilton, Ohio 45011, USA | Phone: (800) 547-9393

BC • 11/2022 | Printed in USA