

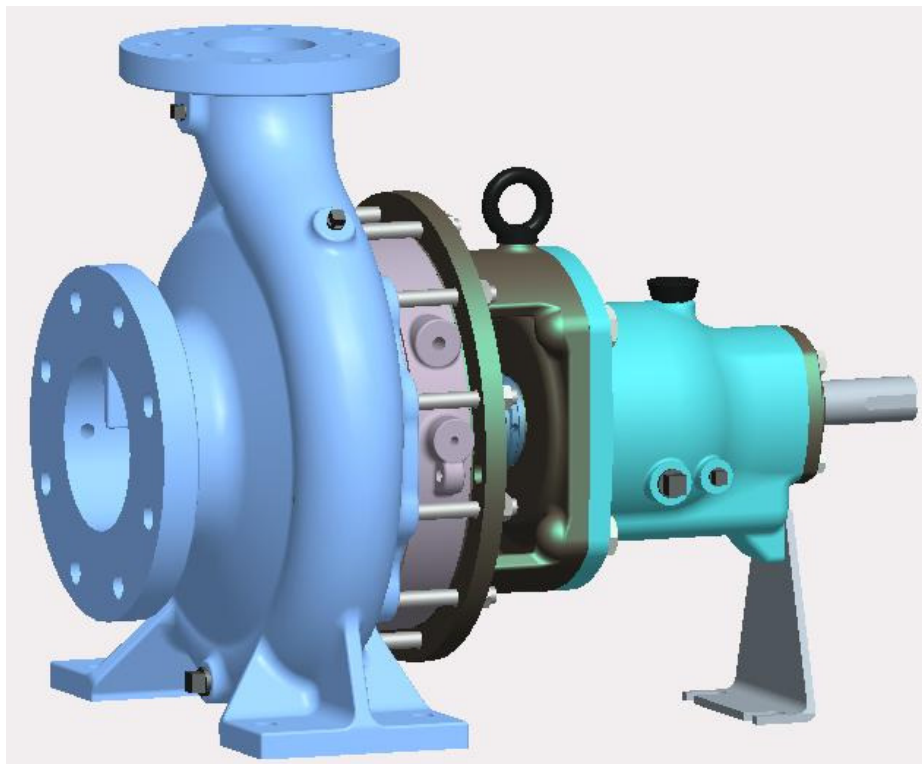

Enriching Lives

# INSTRUCTIONS ON INSTALLATION, OPERATION AND MAINTENANCE FOR KIRLOSKAR PUMP TYPE KPD - KPDQF



**KIRLOSKAR BROTHERS LIMITED**



## **WARRANTY**

**We warrant that the pump supplied from us is free from defective material and faulty workmanship. This warranty holds good for a period of 12 months from the date of commissioning the equipment or 18 months from the date of dispatch from our factory, whichever is earlier. Our liability in respect of any complaint is limited to replacing part/parts free of charge ex-works or repairs of the defective part/parts only to the extent that such replacement / repairs are attributable or arise solely from faulty workmanship or defective material.**

**This warranty holds good only for the products manufactured by us.**

**KIRLOSKAR BROTHERS LIMITED**

### ***CONTENTS:***

- 1) GENERAL**
- 2) SAFETY INSTRUCTIONS**



Enriching Lives

### **3) EQUIPMENT SCHEDULE**

- a) **INSTALLATION**
- b) **MOUNTING & ALIGNMENT**

### **4) OPERATION**

- a) **EQUIPMENT DESCRIPTION.**
- b) **EQUIPMENT OPERATION.**

### **5) MAINTENANCE MANUAL.**

- a) **MAINTENANCE EHS INSTRUCTIONS**
- b) **GENERAL MAINTENANCE DOCUMENTS**
- c) **PREVENTIVE MAINTENANCE**
- d) **CORRECTIVE MAINTENANCE**

### **6) TECHNICAL DATA**

Note: A copy of **General instructions for installation, operation & maintenance of 'Kirloskar pumps'** is attached at the end of this manual.



## 1.0 GENERAL

1.1 'KIRLOSKAR' make KPD - KPDQF pumps are used for handling various types of chemical liquids. These pumps are manufactured to close tolerance and are of rigid construction, However proper installation, operation and maintenance are equally important to ensure trouble free service. This booklet covers important guidelines and instructions for installation, operation and maintenance. These instructions should be followed carefully for satisfactory performance of the pumping unit. Only mechanical aspects are dealt within this booklet.

1.2 Applications:  
KPD pumps are mainly used in process industries like petrochemicals, nuclear, refinery, fertilizer, paper, sugar etc. and power plants. The pump can handle corrosive acids, alkalies, salt solutions, caustics, hydro-carbons, oils, liquefied gases, condensates, viscous liquids etc.

1.3 Nomenclature: KPD32/13  
KPD – Kirloskar Process Development  
32 - Delivery size in mm  
13 - Impeller diameter in cm.

1.4 This booklet covers instructions for following models in KPD, KPDQF, KPD-J, KPD-CLM, of KPD series

| UNIT - 4 | UNIT - 5 |         | UNIT - 7 |         | UNIT - 9 |          | UNIT - 11             |
|----------|----------|---------|----------|---------|----------|----------|-----------------------|
| 20/13*   | 25/16*   | 40/20A# | 25/26A#  | 65/26N# | 65/32    | 125/40   | 125/26 at<br>2900 rpm |
| 20/16*   | 32/13    | 50/13   | 32/26    | 80/16   | 80/32    | 125/40N# |                       |
| 20/20*   | 32/16    | 50/16   | 40/26    | 80/20   | 80/40    | 150/32   |                       |
|          | 32/16A#  | 50/16A# | 40/32    | 80/26   | 80/40N#  | 150/32N# | 80/40DV#              |
|          | 32/20    | 50/20   | 50/26    | 100/16# | 100/26   | 150/40#  | 100/40DV#             |
|          | 32/20A#  | 65/13   | 50/32    | 100/20  | 100/32   | 65/43#   | 200/26#               |
|          | 40/13    |         | 65/16    |         | 100/40   | 125/20#  |                       |
|          | 40/16    |         | 65/20    |         | 125/26   | 150/26#  |                       |
|          | 40/20    |         | 65/26    |         | 125/32   | 100/32N  |                       |

| UNIT -11A | UNIT -11B | UNIT -11C | UNIT - 13 |                         | UNIT - 15 | UNIT - 19 |
|-----------|-----------|-----------|-----------|-------------------------|-----------|-----------|
| 125/45    | 150/43    | 200/33    | 200/38M#  | 250/33A#                | 250/50#   | 150/56    |
|           |           |           | 200/46#   | 250/33B                 | 250/40#   | 350/40    |
|           |           |           | 150/52#   | 125/32 at<br>2900 rpm # |           |           |
|           |           |           | 150/28#   |                         |           |           |
|           |           |           | 200/36#   |                         |           |           |

### Notes:

- a) \* marked pumps are supplied with semi-open type impeller as a standard supply.



b) # marked pumps are supplied with "Enclosed" type impeller only.

1.5 Description KPD pumps.

- KPD- KPD pumps with enclosed impeller (with casing cover for heating/cooling arrangement.)
- KPD-QF KPD pumps with semi open impeller.
- KPD-J- KPD pumps with jacketed delivery, casing and casing cover.
- KPD-CLM KPD pumps with center line mounting arrangement (Above 180°C)
- KPD-V KPD pumps with vertical execution arrangement.

1.5 Nameplate information:

Every pump has the following nameplate fitted to bearing housing (24000) provided with necessary identification of the pump and its specific hydraulic characteristics.

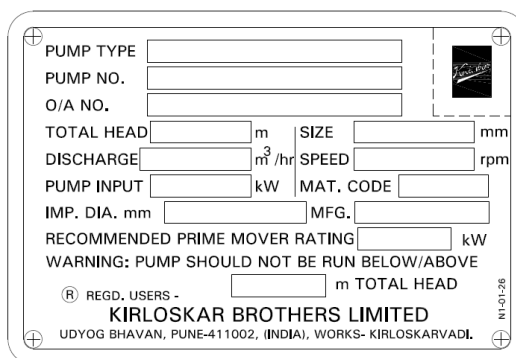

Fig. 1. Duty name plate

The nameplate must not be removed. Loss of this plate could make identification impossible. This in turn could affect safety and cause difficulty in obtaining spare parts.

- 1.6 The complete range of 'KPD' pump is covered by eleven driving units for achieving interchangeability and thereby reducing inventory.
- 1.7 Pumps when properly installed & given due care in operation & maintenance should operate satisfactorily for a long period.
- 1.8 When the pump is received, it should be inspected & located in dry place before the actual use of pump. The coupling should be rotated once in a month to prevent pitting of bearing surfaces.

2.0 Safety Instructions:

2.1: General Information

Before performing any actions detailed within this instruction, the site Health and Safety instructions and the instructions in this document shall be read and fully understood.

Whenever the equipment is operated, maintained or used in any way, the procedures detailed within these instructions shall be followed. The pump supplied by Kirloskar Brothers Limited (KBL) has been designed with safety in mind; where hazards cannot be eliminated, the risk has been minimized by the use of guards and other design features. Some hazards cannot be guarded against and the instructions below **MUST BE COMPLIED WITH** for safe operation. These instructions cannot cover all circumstances. It is the responsibility of the user of the equipment for maintaining safe working practices at all times. The pumps are supplied with stickers for hazard, caution and safety wherever these are applicable.

2.1.1 Within the manual, safety instructions are marked with safety symbols.

Hazard.



This symbol refers to general mechanical aspects of safety.

Hazard.



This symbol refers to electrical safety.



This symbol is used to introduce safety instructions whose non-observance may lead to damage to the machine and its functions.

2.1.2 KBL products are designed for installation in designated areas, which are to be kept clean and free of obstructions that may restrict safe access to the controls and maintenance access points.

2.1.3 KBL firmly insists that all personnel responsible for installation, operation and maintenance of the equipment must read the manual before any work is done. Before commissioning, the operating staff have to be instructed in the guidelines for correct and safe operation of the product as stated in these instructions.

2.1.4 Access to the equipment should be restricted to the personnel responsible for installation, operation and maintenance and they must be trained, adequately qualified and supplied with the appropriate tools for their respective tasks. The scope of responsibilities and supervision of the personnel must be exactly defined by the plant operator.

2.1.5 This product must be serviced by qualified personnel who are familiar with the design and operation of this product and the system with the essential safety aspects involved.



- 2.1.6 Our guarantee will be valid only if the installation, operation, maintenance and repairs of this pump are carried out in accordance with these instructions. The plant operator is to make sure that the contents of these instructions are fully understood by the operating personnel. During operation, periodic inspections should be made to assure safe operation under the prevailing conditions.
- 2.1.7 Any modification may be made to the product only after consultation with the manufacturer. Using spare parts and accessories authorized by the manufacturer is a relevant safety aspect. Only genuine spare parts which are in accordance with the original delivery (in the parts list) are to be used.
- 2.1.8 Ear defenders should be worn where the specified equipment noise level exceeds locally defined safe levels. Safety glasses or goggles should be worn where working with pressurized systems and hazardous substances. Other personal protection equipment must be worn where local rules apply.

**Caution**

- 2.2 *DO NOT* wear loose or frayed clothing or jewellery, which could catch on the controls or becomes trapped in the equipment.
- 2.3 Operation of the equipment for the application other than for which it is supplied can increase the risk from hazards. Please consult KBL before making such change in the application of the equipment.
- 2.4 Improper installation, operation and maintenance of the product supplied by KBL could result in injury or death.

**Caution**

- 2.5 In case of KPD CLM pumps which are handling fluid at very high temperature, the operator should avoid touching the pump in running condition. Use safety equipments like hand gloves and safety shoes while operating KPDCLM pumps.

**2.6: Transport handling and storage instructions:**

**2.6.1: Transport.**

Pumps are dispatched in duly assembled condition. Lubricating oil in the bearing housing is drained prior to dispatch of pump. Pumps are protected against corrosion and packed for transport by normal road, rail and sea carriers.

**2.6.2: Handling**



**Crushing hazard**

When lifting the pump or pump set, use lifting equipment having a safe working load rating suitable for the weight specified. Use suitable slings for lifting any pump not provided with lifting points.

The use of suitable forklift truck and four chain crane sling equipment is recommended but locally approved equipment rating may be used.

Pump should be slung as shown.

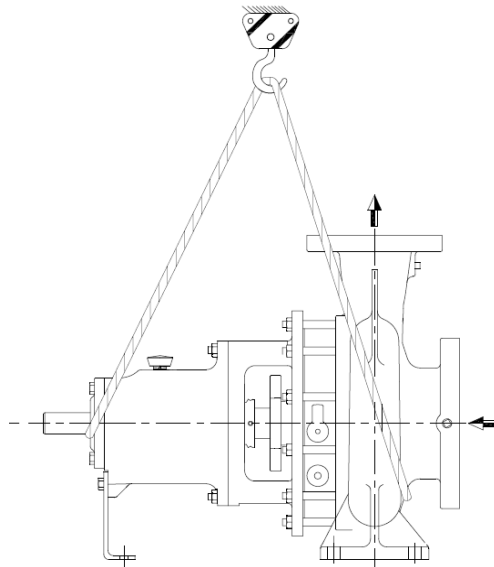

*Fig. 2. Lifting of bare shaft pump*

### **Caution**

Pump set must be lifted from the lifting holes provided using suitable four chain lifting equipment.

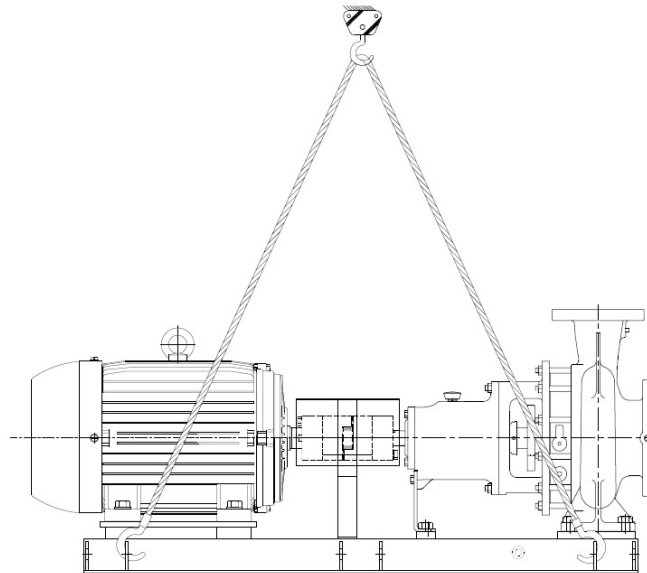

*Fig. 3 Lifting of Pumpset*

### **2.6.3: Storage.**

#### **2.6.3.1: Temporary storage for up to six weeks.**

If the pump unit is not be used immediately it should be stored carefully in a horizontal position, in a sheltered and dry location.



**Caution**

Additional rust preventive should be applied to all unpainted carbon steel or cast iron parts, and should not be removed until final installation.

**2.6.3.2: Long Term Storage.**

If the pump is not to be installed and operated soon after arrival, store it in a clean, dry place, having slow, moderate changes in ambient temperature. Step should be taken to protect the pump from moisture, dust, dirt, and foreign bodies. It is recommended that the following precautions to be taken:

- a) Ensure that the bearings are packed with the recommended grease, to prevent moisture from entering around the shaft.
- b) Remove the glands, packings and lantern rings from the stuffing box if the pump is equipped in this manner. If the pump is equipped with mechanical seal, dismantle and coat the seal with light oil.
- c) Ensure that suction and discharge branches of the pump and all other openings are covered with cardboard, wood or masking tape to prevent foreign objects entering the pump.
- d) If the pump is to be stored where there is no protective covering, it is advisable to cover the unit with a tarpaulin or other suitable covering.
- e) The pump shaft should be manually rotated periodically to prevent pitting of the bearing surfaces due to moisture.

**Shearing Hazard**

DO NOT place fingers or hands etc. into the suction or discharge pipe outlets and do NOT touch the impeller, if rotated this may cause severe injury. To prevent ingress of any objects, retain the protection covers or packaging in place until removal is necessary for installation. If the packaging or suction and discharge covers are removed for inspection purposes, replace afterwards to protect the pump and maintain the safety.

Fill the bearing housing with recommended oil to ensure that the shaft and bearings remain rust free.

**2.6.3.3: Exposed or Extreme Conditions Storage.**

For exposed storage or extreme variants in atmospheric or environmental conditions, please refer to KBL for special storage instructions to suit the conditions acceptable.

**3.0 Equipment schedule:****3.1 Installation:**

- 3.1.1 For location, preparing foundation, installation, alignment, piping, general maintenance, trouble shooting etc. the instructions given in our publication -'GENERAL INSTRUCTIONS FOR INSTALLATION, OPERATION AND MAINTENANCE OF KIRLOSKAR CENTRIFUGAL PUMPS' which is also printed along this booklet must be followed very carefully. If the pump is



drawing liquid from the vessel under vacuum, then vacuum equalizing connection piping must be made as per instruction given in above publication. The external sealing connection to the pump, if applicable, must be made after installing and before commissioning the pump. Pump on hot service must have final coupling alignment made with the unit at its operating temperature.

### 3.1.2 Receiving pump

Upon receipt of the pump, a visual check should be made to determine if any damage occurred during transit or handling. The main items to look for are:-

- a) Broken or cracked equipment, including base, motor or pump feet and flanges.
- b) Bent of shaft
- c) Broken motor end bells, bent eyebolts or damaged boxes of motor
- d) Missing parts.
- e) Pump shaft rotates freely.

**Parts or accessories are some times wrapped individually or fastened to the equipment. If any damage or losses have been incurred; promptly notify your KBL representative, KBL Dealer and the transport company who delivered the pump.**

When unloading pump units, lift equally at four or more points from the base.

**Caution**

DO NOT LIFT ONLY THE DRIVER OR PUMP.

### 3.1.3 Preparation

- Before installing the pump, clean the suction and discharge flanges thoroughly.
- Remove the protective coating from the pump shaft.
- If the pump has been in storage and prepared for storage in the manner outlined previously, remove all the grease from the bearings. The bearings should then be flushed with carbon tetrachloride or kerosene and relubricated.

### 3.1.4 Location

- The pump should be installed as near the liquid source as possible, with the shortest and most direct suction pipe practically.
- The pump should be installed with sufficient accessibility for inspection and maintenance. Ample space and head room should be allowed for the use of an overhead crane or hoist sufficiently strong to lift the unit.
- Make sure there is a suitable power source available for the pump driver. If motor driven, electrical characteristics should be identical to those shown on motor data/ name plate.

### 3.1.5 Foundation



- The foundation should be strong enough to reduce vibrations and rigid enough to avoid any twisting or misalignment.
- The foundation should be poured without interruptions to within 20 to 40 mm of the finished height. The top surface of the foundation should be well scored and glued before the concrete sets. This provides a bonding surface for the grout. Foundation bolts should be set in concrete as shown in fig. Allow enough bolt length for grout, shims, lower base plate flange, nuts and washers. The foundation should be allowed to cure for several days before the base plate is shimmed and grouted.

### 3.1.6 Base plate setting

- Use blocks and shims under base for support at foundation bolts and midway between bolts, to position base approximately 25 mm above the concrete foundation with studs extending through hole in the base plate.
- By adding or removing shims under the base, level the pump shaft and flanges. The base plate does not have to be leveled. Draw foundation bolt nuts tight against base plate and observe pump and motor shafts or coupling hubs for alignment.
- Check to make sure the piping can be aligned to pump flanges without placing pipe strain on either flange.
- Grout base plate in completely and allow grout to dry thoroughly before attaching piping to pump (24 hours is sufficient time with approved grouting procedure).

### 3.6 Grouting procedure

Grout compensates for uneven foundation, distributes weight of unit and prevents shifting. Use an approved, non-shrinking grout as follows, after setting and leveling unit

- Build strong form around foundation to contain grout.
- Soak top of concrete foundation thoroughly, then remove surface water.
- Base plate should be completely filled with grout and, if necessary, drill vent holes to remove trapped air.
- After grout has thoroughly hardened, check the foundation bolts and tighten if necessary.
- Check the alignment after the foundation bolts are tightened.
- Approximately 14 days after the grout has been poured or when the Grout has thoroughly dried, apply an oil base paint to the exposed edges of the grout to prevent from air and moisture coming in contact with the grout.

### 3.8 Suction and Discharge Piping



When installing the pump piping, make sure to observe the following precautions:-

- Piping should always run to the pump. Do not move pump to pipe. This could make final alignment impossible.
- Both suction and discharge piping should be supported independently and close to pump so that no strain is transmitted to the pump when the flange bolts are tightened.
- Use pipe hangers or other supports at necessary intervals to provide support. When expansion joints are used in the piping system, they must be installed beyond the piping supports close to the pump.
- It is advisable to increase the size of both suction and discharge pipes at the pump connection to decrease the loss of head from friction.
- Install piping as straight as possible, avoiding unnecessary bends. Where necessary, use long sweep 90 degree bend to decrease friction losses.
- Make sure that all piping joints are air tight. Provide pipe expansions bellows when hot fluids are to be pumped. Where reducers are used, eccentric reducers are to be fitted in suction lines and straight taper reducers in discharge and vertical lines.
- Misuse of reducers may cause the formation of air pockets in the pipe and thus preventing the correct operation of the pump.
- The suction pipe should be as short & direct as possible. Where suction lift is not very high, it is advisable to use a foot valve. Horizontal suction line must have a gradual rise to the pump.
- The discharge pipe is usually preceded by a non-return valve or check valve and a discharge gate valve. The check valve is to protect the pump from excessive back pressure and reverse rotation of the unit and to prevent back flow into the pump in case of stoppage or failure of the driver. The discharge valve is used in priming, starting and when shutting down the pump.

### **3.2 MOUNTING AND ALIGNMENT**

A spacer type flexible coupling is used to connect pump shaft to the driver. By using spacer type of coupling, the complete rotating unit can be removed from the volute without removing pump casing or rotor and without disconnecting piping connections. This also avoids any realignment of pump and motor after re-assembly of rotating unit. However other types of coupling can be supplied against request.

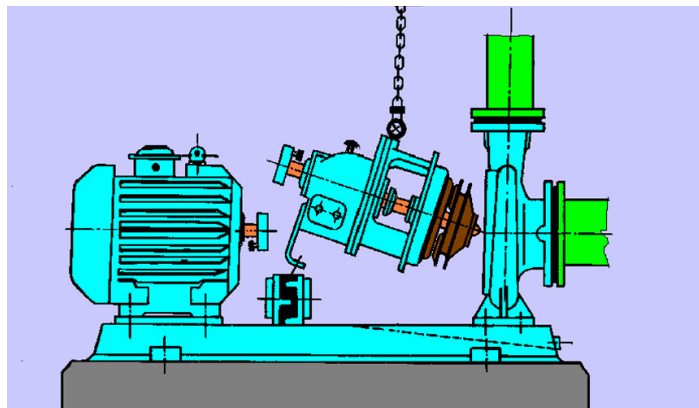

Fig.4 Back pull out assembly of KPD pump

### 3.2.1 ALIGNMENT

The pump driver, if supplied, is correctly aligned on its base plate at the factory. A certain amount of deformation of the base plate is possible during transit and it is therefore essential to check alignment, prior to final grouting.

**A flexible coupling will only compensate for small amount of misalignment and should not be used to compensate for excessive misalignment of the pump and driver shafts.**

**Inaccurate alignment results in vibration and excessive wear on the bearings, sleeve or shaft and wear rings.**

**ALWAYS REMEMBER "A FLEXIBLE COUPLING IS NOT A UNIVERSAL JOINT"**

Correct alignment is essential for the smooth operation of the pump. There are two types of misalignment between the pump shaft and the drive shaft, which are:

1) **Angular misalignment** – shaft with axis concentric, but not parallel.

Maximum allowable misalignment is 1°

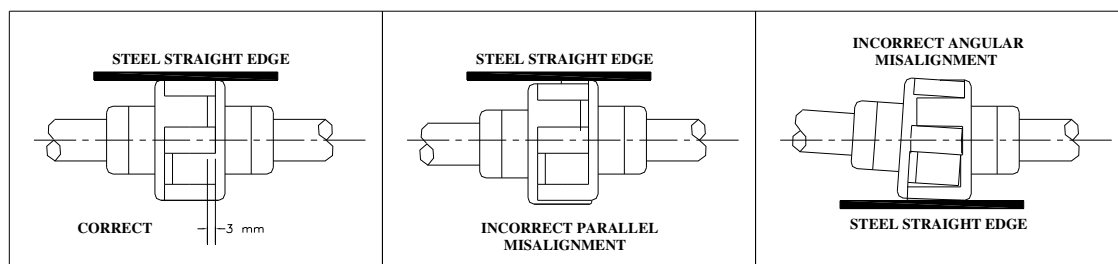

Fig. 5 Checking coupling alignment with straight edge

2) **Parallel misalignment** – shaft with axis parallel, but not concentric.

Maximum allowable misalignment is 0.2 mm

This misalignment is checked by using a straight edge as shown in figure 1 given above. Coupling alignment can be checked with dial gauge Indicator. Alignment should be performed after the base plate has been properly set

and grout has dried thoroughly according to instructions. Final alignment should be made by shimming driver only.

Alignment should be made at operating temperatures.

After final alignment, it is necessary to dowel pump and driver feet to the baseplate.

#### FACTORS THAT MAY DISTURB ALIGNMENT

The unit should be periodically checked for alignment. If the unit does not stay in line after being properly installed, the following are possible reasons:

- a) Setting, Seasoning of the foundation.
- b) Pipe strains, distorting or shifting of the machines.
- c) Wear of the bearings.

3.2.1.1. Before commissioning the pump set, please ensure:

3.2.1.2. The pipe connections are flushed and tightened properly.

A) Alignment is proper.

B) Auxiliary piping connections such as sealing connections, cooling connections etc are made.

Please refer to Figure 2 given below for plugs and piping connections.

#### KPD PUMPS – TAPPING CONNECTION CHART

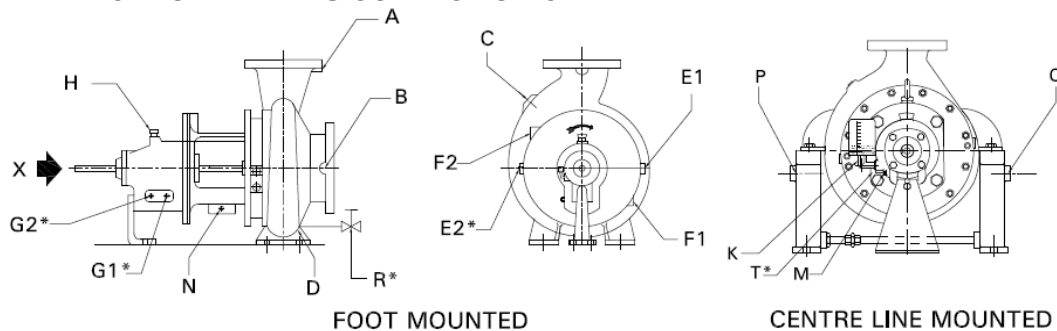

*Fig. 6 KPD Pump tapping details*



| Code | Description  | Location of connection when viewed from driving end |
|------|--|---|
| A    | Gauge connection discharge side.                       | On pump discharge flange.                           |
| B    | Gauge suction side.                                    | On suction flange right.                            |
| C    | Flushing line connection.                              | On casing top left.                                 |
| D    | Pump casing drain.                                     | On pump casing bottom side towards suction.         |
| E1   | Stuffing box Flushing inlet.                           | On casing cover, top left.                          |
| E2*  | Stuffing box Flushing outlet.                          | On casing cover, bottom right.                      |
| F1   | Stuffing box cooling water inlet.                      | On casing cover, bottom right.                      |
| F2   | Stuffing box cooling water outlet.                     | On casing cover, top left.                          |
| G1*  | Bearing housing cooling water inlet.                   | On bearing housing right.                           |
| G2*  | Bearing housing cooling water outlet.                  | On bearing housing right.                           |
| H    | Breather cap.  | On bearing housing top.                             |
| J1 - | St. box jacket heating steam inlet.                    | Casing cover top left (in place of F2).             |
| J2 - | St. box jacket heating steam outlet.                   | Casing cover right bottom (in place F1).            |
| K    | Constant level oiler.                                  | On bearing housing left.                            |
| M    | Bearing housing oil drain.                             | On bearing housing left.                            |
| N*   | Drip pan drain.  | On lantern bracket bottom right.                    |
| P    | Pad cooling water inlet for centerline mounted pumps.  | On pad for centerline mounted pump casing.          |
| Q    | Pad cooling water outlet for centerline mounted pumps. | On pad for centerline mounted pump casing.          |
| R*   | For drain cock and piping.                             | On pump casing bottom.                              |
| S    | Drain taping for drain rim type base.                  | Base.   |
| T*   | Thermowell (Temperature gauge)                         | On bearing housing left near constant level oiler.  |
| W1-  | Pump casing jacket drain.                              | On pump casing jacket bottom left.                  |
| W2-  | Pump casing jacket heating water / steam outlet.       | On pump casing jacket bottom right.                 |
| W3-  | Pump casing jacket heating water / steam inlet.        | On pump casing jacket top left.                     |

**Tapping size details for KPD pump:**

| SR. NO. | CODE OF PIPE CONN | DESCRIPTION                              | SIZE OF CONNECTION |        |        |                        |          |          |
|---------|-------------------|--|--------------------|--------|--------|------------------------|----------|----------|
|         |                   |  | UNIT-4             | UNIT-5 | UNIT-7 | UNIT-9,11, 11A,11B,11C | UNIT -13 | UNIT -15 |
| 1       | A                 | Gauge connection discharge side          | 1/4                | 1/4    | 1/4    | 1/2                    | 1/2      | 1/2      |
| 2       | B                 | Suc. Gauge / Vaccum equilising conn      |                    |        |        |                        |          |          |
| 3       | C                 | Flushing/Sealing conn. From pump casing. | 1/4                | 1/2    | 1/4    | 1/4                    | 1/2      | 1/2      |
| 4       | D                 | Pump casing drain                        | 1/2                | 1/2    | 1/2    | 1/2                    | 1/2      | 1/2      |
| 5       | E                 | Stuffing box sealing                     | 3/8                | 3/8    | 3/8    | 3/8                    | 1/2      | 1/2      |



|    |        |   |            |     |     |     |     |     |
|----|--------|---|------------|-----|-----|-----|-----|-----|
|    |        | inlet   |            |     |     |     |     |     |
| 6  | E1*    | Stuffing box sealing outlet                             |            |     |     |     |     |     |
| 7  | F      | Stuffing box cooling water inlet                        | 1/2        | 1/2 | 1/2 | 1/2 | 1/2 | 1/2 |
| 8  | F1     | Stuffing box cooling water outlet                       |            |     |     |     |     |     |
| 9  | G1*    | Bearing housing cooling water inlet                     | 1/2        | 1/2 | 1/2 | 1/2 | 1/2 | 1/2 |
| 10 | G2*    | Bearing housing cooling water outlet                    |            |     |     |     |     |     |
| 11 | H      | Air breather plug                                       | 20 mm hole |     |     |     |     |     |
| 12 | K      | Constant level oiler                                    | 1/4 BSP    |     |     |     |     |     |
| 13 | M      | Baring housing oil drain                                |            |     |     |     |     |     |
| 14 | N*     | Drip pan drain  | 1/2        | 1   | 1/2 | 1/2 | 1/2 | 1/2 |
| 15 | P<br>Q | Pad cooling for centerline mounted pump outlet & inlet. | 1          | 1/2 | 1   | 1   | 1   | -   |
| 16 | R*     | Drain cock and piping                                   | 1/2        | 1/2 | 1/2 | 1/2 | 1/2 | 1/2 |
| 17 | S      | Drain tapping for drain rim type base                   | 1          | 1   | 1   | 1   | 1   | 1   |
| 18 | T*     | Thermowell (Temperature gauge)                          | 1/2        | 1/2 | 1/2 | 1/2 | 1/2 | 1/2 |

Notes :

All tappings are in inches and location of connections are specified looking from arrow "X".

\* This special provision on request only and at extra cost.

All connections are NPT except specified.

**TAPPING CONNECTION CHART- KPD PUMPS - UNIT19**

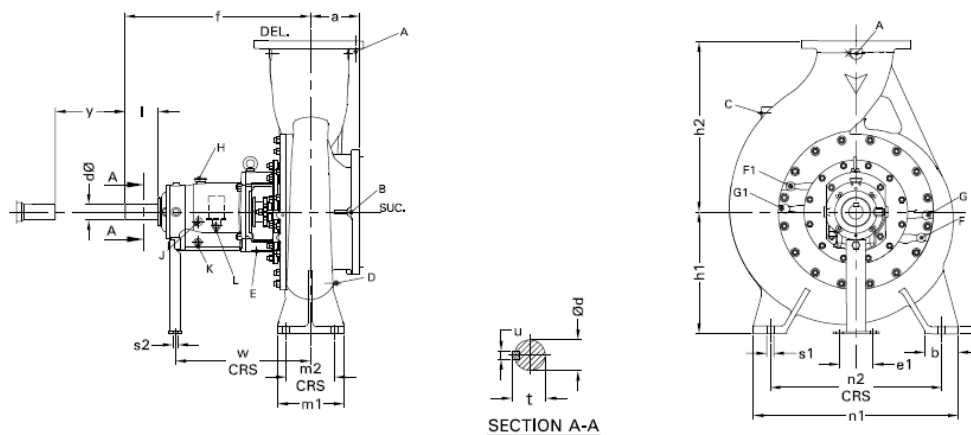





| TAG. | CONNECTION DETAILS                      | CONNECTION SIZE |                |
|------|---|-----------------|----------------|
|      | PUMP TYPE                               | KPD 150/56      | KPD 350/40     |
| A    | DISCHARGE PRESSURE GAUGE                | G 1/2" NPT/BSP  | G 1/2" NPT/BSP |
| B    | SUCTION PRESSURE GAUGE                  | G 1/2" NPT/BSP  | G 1/2" NPT/BSP |
| C    | CIRCULATION LIQUID INLET                | G 1/2" NPT/BSP  | G 1/2" NPT/BSP |
| D    | CASING DRAIN                            | G 1/2" NPT/BSP  | G 3/4" NPT/BSP |
| E    | LEAKAGE DRAIN                           | G 1/2" NPT/BSP  | G 1/2" NPT/BSP |
| F    | ST. BOX. COOLING WATER INLET            | G 1/2" NPT/BSP  | G 1/2" NPT/BSP |
| F1   | ST. BOX. COOLING WATER OUTLET           | G 1/2" NPT/BSP  | G 1/2" NPT/BSP |
| G    | SEALING LIQUID INLET                    | G 1/2" NPT/BSP  | G 1/2" NPT/BSP |
| G1   | SEALING LIQUID OUTLET                   | G 1/2" NPT/BSP  | G 1/2" NPT/BSP |
| H    | BEARING HOUSING VENT / OIL FILLING PLUG | Ø20             | Ø20            |
| L    | CONSTANT LEVEL OILER                    | G 1/4" NPT/BSP  | G 1/4" NPT/BSP |
| J    | OIL LEVEL INDICATOR                     | G 1/2" NPT/BSP  | G 1/2" NPT/BSP |
| K    | OIL DRAIN PLUG                          | G 1/2" NPT/BSP  | G 1/2" NPT/BSP |

### 3.2.1.1 CONSTANT LEVEL OILER

KPD pumps are oil lubricated as standard scope of supply. Pump is provided with constant level oiler.

Fix the constant level oiler and fill the oil. Procedure for fitting the constant level oiler and the method of filling oil is given below.

Constant level oiler has plastic container in aluminum body as a standard supply. Connection stem is ¼ inch BSP tapped and its capacity is 70 ml approximately. If the constant level oiler is properly fitted and oil is filled as per instructions given, practically no attention is required as far as lubrication of bearing is concerned other than to replenish the visible reserve supply of the oil in the container ref figure given below.

### 3.2.1.2 METHOD OF FITTING

Screw constant level oiler stem into the tapped hole of the bearing housing reservoir. Before fitting oiler, check the level of the tapped hole with the help of a turned bar with ¼ inch BSP tapping at one end and a spirit level. See figure, if the level is incorrect and oiler tilts downward, oil will not flow from oiler into the reservoir (see fig given below.). Hence it is necessary to check the level before fitting in the constant level oiler.

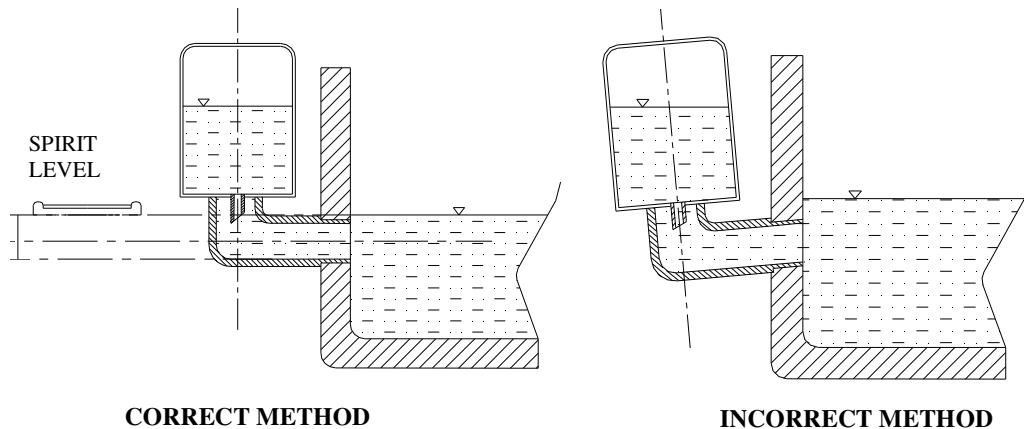

**CORRECT METHOD**

**INCORRECT METHOD**

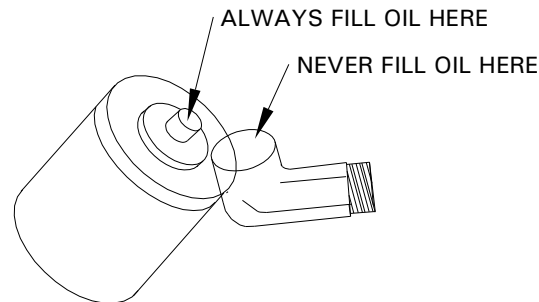

*Fig. 7 Method of fitting constant level oiler*

### 3.2.1.3 Method of filling the oil.

Tilt the container and fill it with oil through stem of the oiler. Replace the container and allow oil to flow into reservoir. The oil in the container shall flow into the bearing housing reservoir and shall become empty. Repeat above procedure till the level in the reservoir is equal to the level of which the oiler is adjusted. When the desired level is attained, the oil in the container shall remain steady at a position. Visible level of the oil in the container indicates that bearing housing is filled up to mark.

#### **Caution**

- 1) In no case oil should be filled directly in to the bearing housing reservoir, through breather cap.
- 2) Replenish the visible reserve supply of oil in the container as oil is used up.
- 3) Please ensure that air 'GROOVE' provided on Aluminum body on which plastic container rests is not clogged with dust / fiber oil film etc. this groove allows atmospheric air to enter inside the body, to maintain oil level in bearing housing.

## 4.0 Operation.

### 4.1 EQUIPMENT DESCRIPTION:



End suction centrifugal pump type KPD is from KBL manufactured process pump series which dimensionally conforms to DIN 24256 / ISO 2858.

The mechanical assembly comprises a rigid shaft, supported by a pair of bearings with a double / single shrouded impeller mounted in a removable bearing housing assembly. This is attached to an end suction volute casing fitted with wear rings / wear plate. The bearing housing, shaft and impeller assembly can be withdrawn from the volute for maintenance without disconnection of pipe work.

The discharge branch is positioned vertically upwards while suction branch is horizontal and is at 90° to discharge nozzle. An additional mounting foot is fitted at the outer bearing position for stability.

The complete assembly is of rigid construction, being intended for mounting on suitable base plate with electric motor / internal combustion engine. A suitable coupling is provided to transmit the rotational drive between pump and motor. A spacer coupling most suitable to use, because it allows the removal of the pump rotating assembly without disconnecting suction pipe, discharge pipe and motor.

Gland packing or mechanical seal is used to seal the leakage of pumped liquid across the shaft.

## **4.2 EQUIPMENT OPERATION.**

### **4.2.1 Before starting the pump check the following:**

- 1) The pump rotates freely by hand.
- 2) The level of the oil in the constant level oiler is up to the mark.
- 3) The sealing liquid and cooling water connections are properly tightened and adjusted.
- 4) The direction of rotation of driver. It should correspond to the direction of rotation of pump.
- 5) The pump casing and the suction pipeline is fully primed with the liquid.
- 6) Valve on delivery side is closed.
- 7) The cock for pressure gauge connection is closed.
- 8) The gland bolts are properly tightened.
- 9) For KPD-J pumps before each start up of pump, circulate steam/hot water to pump casing and casing cover jacket for a period of about ½ hour to ensure that all solidified liquid is melted.

### **4.2.2 Starting the pump**

- 1) In case of external liquid for sealing/ quenching, start the liquid supply before starting the pump.
- 2) Start the pump. Let the prime mover pickup its full speed.
- 3) Open the valve on delivery line gradually.
- 4) Regulate the required flow by adjusting the delivery valve.
- 5) Open the cock for pressure gauge connection.



#### 4.2.3 During running the pump check the following things and regulate if needed

- 1) The pump is running smooth.
- 2) The flow of sealing liquid and cooling / heating water is uninterrupted. If necessary, provide sight glass in the piping.
- 3) The bearings are not getting abnormally hot.
- 4) The gland is properly tightened to ensure sufficient leakage to dissipate heat generated. Maximum permissible leakage is 60 to 80 drops per minute.
- 5) Head and capacity developed by the pump is as specified.
- 6) Power consumption is within limit.
- 7) Ensure that there is no mechanical friction in the pump.
- 8) Stop the pump immediately, if any, defects are detected. Do not start the pump unless the defects are rectified. If it is not possible to rectify the defects then report immediately to the supplier or authorized dealer or nearest KBL office.

#### 4.2.4 During stopping the pump

- 1) Close the valve on the delivery line. Ensure that pump will not run for more than few seconds in this condition.
- 2) Stop the motor.
- 3) Close the cooling water and sealing liquid connections.
- 4) If the pump is not required to be operated for a long time, drain the pump casing completely. If the pump is required to be stored for a long time, the bearing housing should be dried internally with hot air and should be flushed with moisture free protective such as light oil or kerosene.
- 5) If any cooling and flushing arrangements are provided then it must be drained and dried.

### 5.0 MAINTENANCE MANUAL.

#### 5.1 MAINTENANCE EHS INSTRUCTIONS

Following hazards may arise during maintenance work.



#### Fluid Pressure Jet Hazards

Check and ensure that the pump operates at below the maximum Working Pressure specified.



#### Hazardous materials:



Wear a suitable mask or respirator when working with chemical material handling.



### **Hazardous Gases, Mists, Sprays and Leaks.**

Be aware of the hazards relating to the pumped fluid, especially the danger from inhalation from noxious and toxic gases, skin and eye contact or penetration. Obtain and understand the hazardous substance data sheets relating to the pumped fluid and note the recommended emergency and first aid procedures.

Before attempting any maintenance on a pump, particularly if it has been handling any form of hazardous liquid; ensure that the unit is safe to work on. The pump must be flushed thoroughly with suitable cleaner to purge away any of the product left in the pump components. The plant operator should carry this out and a certificate of cleanliness obtained before starting work. To avoid any risk to health it is also advisable to wear protective clothing as recommended by the site safety officer, especially when removing old packing that may be contaminated.



### **Electric shock and accidental starting hazard:**

Isolate the equipment before any maintenance work is done. Switch off the mains supply, remove fuses, apply lockouts where applicable and affix suitable isolation warning signs to prevent inadvertent re-connection.

In order to avoid the possibility of maintenance personnel inhaling dangerous fumes or vapors, it is recommended that maintenance work be carried out away from the pump location by removal of the rotating unit assembly to a suitable maintenance area.

## **5.2 GENERAL MAINTENANCE DOCUMENTS:**

### **1) Maintenance documents:**

- i) Pump Sectional assembly drawing with part list
- ii) Pump Outline dimension drawing
- iii) Mechanical seal assembly / GA drawing
- iv) Foundation plan drawing
- v) Pump datasheet

### **2) Specific maintenance data:**

#### **5.2.1: Overhauling:**

#### **Procedure for dismantling and re-assembly**

While dismantling and re-assembling, the cross-sectional assembly drawing and specification part list should be referred.

### 5.2.1.1 Dismantling:

Follow the following simple steps to dismantle the pump.

- 5.2.1.1.1 Isolate power supply to motor.
- 5.2.1.1.2 Shut off the valves controlling flow to and from the pump.
- 5.2.1.1.3 Drain the liquid from pump by removing the drain plug (60100), or open the pump casing drain cock.
- 5.2.1.1.4 Remove all auxiliary tubing and piping. Remove safety mesh guard.
- 5.2.1.1.5 Drain the lubricating oil from the bearing housing (24000) and remove constant level oiler (44300).
- 5.2.1.1.6 We recommend matching the punch mark of the coupling halves.
- 5.2.1.1.7 In case of the pumps with spacer type flexible couplings, disconnect coupling (pump half and motor half) from the coupling spacer and remove coupling spacer. In case of ordinary flexible couplings, remove the motor from the base.

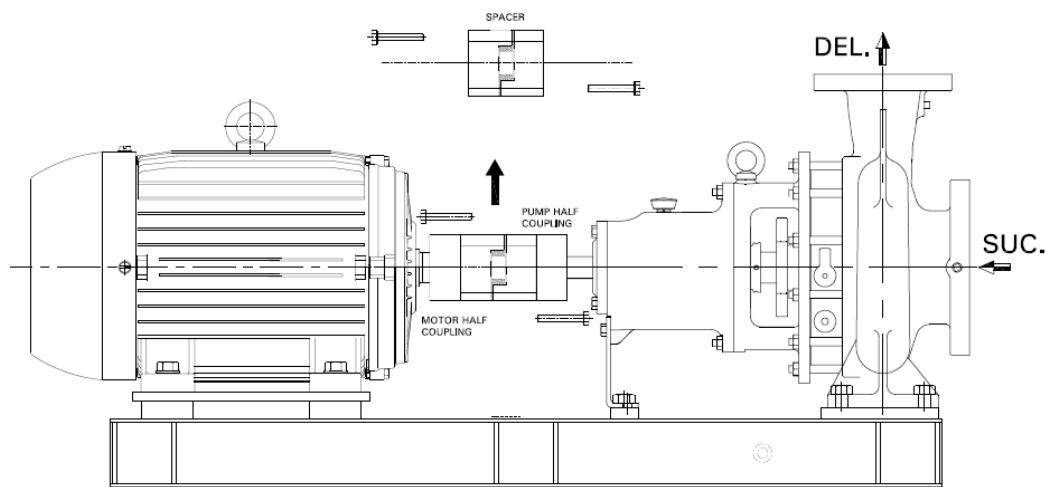

*Fig. 8. Removal of coupling*

- 5.2.1.1.8 Remove the support foot (25100) hold down bolts.

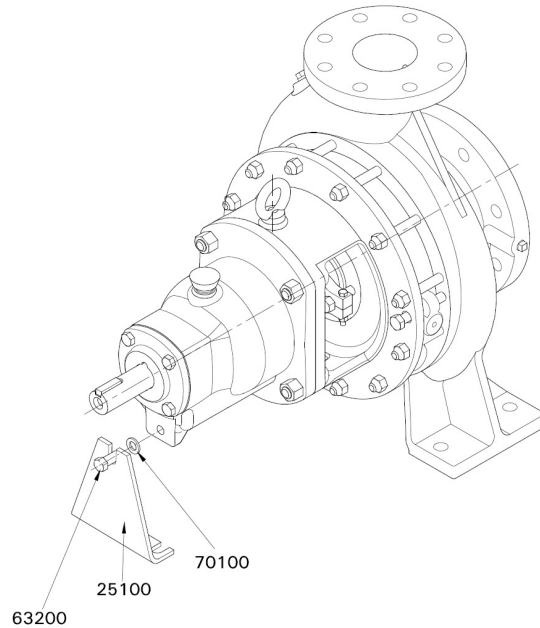

Fig. 9. Removal of support foot

5.2.1.1.9 Adjust string or chain tension to support the weight of the back pull out assembly.

5.2.1.1.10 In case of casing cover sandwiched between casing and lantern bracket, remove the hexagonal nuts from casing stud holding the lantern bracket (24800) to pump casing (10500).

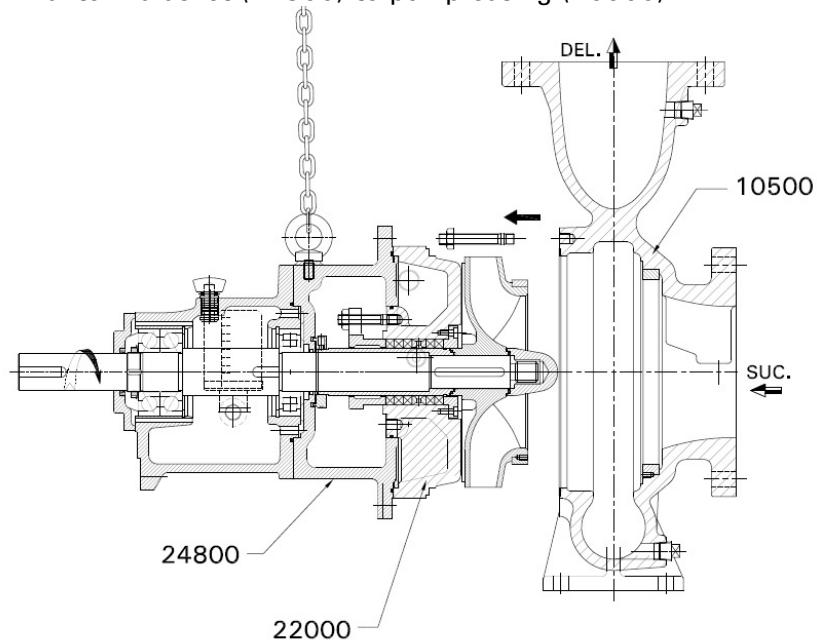

Fig. 10. Removal of back pull out assembly – casing cover is sandwiched

5.2.1.1.11 In case of casing cover is tightened directly to casing (i.e. casing cover is not sandwiched between casing and lantern bracket),

remove the hexagonal nuts from casing stud holding the casing cover (22000) to pump casing (10500).

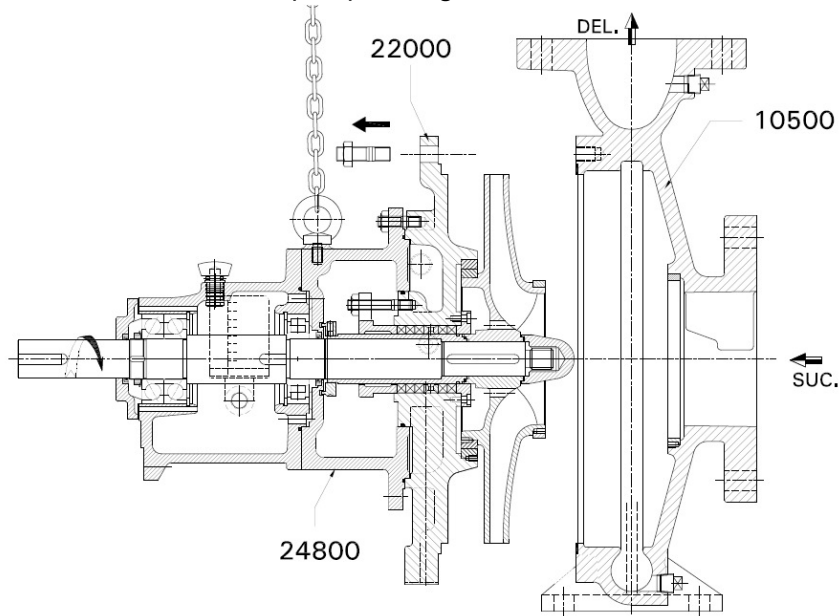

Fig. 11 Removal of back pull out assembly – casing cover is not sandwiched

- 5.2.1.1.12 Screw the release bolts provided in casing cover. Turn bolts evenly through a quarter turn at both sides.
- 5.2.1.1.13 Slightly pull out the driving unit till impeller (15100) clears the pump casing (10500).
- 5.2.1.1.14 Place this rotating unit on a table or clean and dry place for further dismantling.
- 5.2.1.1.15 Remove casing gasket (51101).
- 5.2.1.1.16 Unscrew the impeller nut (33000 / 33001). Remove the gasket between impeller and impeller nut (68201).

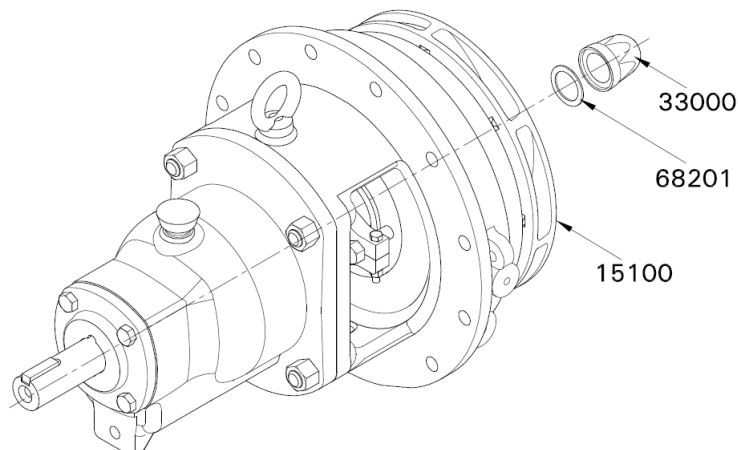
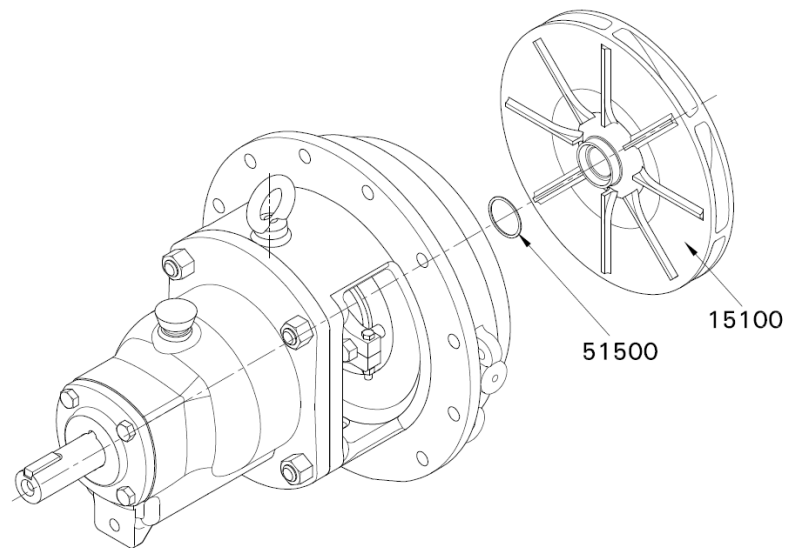

Fig. 12. Removal of impeller nut and gasket

- 5.2.1.1.17 Take out the impeller (15100) from pump shaft (18002). Remove the gasket between impeller and shaft sleeve (51501).





*Fig. 13. Removal of impeller*

#### 5.2.1.1.18

#### **Removal of stuffing box with gland packing:**

For this following steps should be followed –

- a) Remove split gland (22900) by loosening the nuts used for tightening the gland.
- b) Take out casing cover (22000) along with stuffing box bush (35000), gland packing (43000), lantern ring (22700), 'O' ring for casing cover (52501) will also come out along with it.
- c) Take out 'O' ring for lantern bracket (52502).
- d) Unscrew the hex socketted screw clamping stuffing box bush (35000) to casing cover (22000) and remove the stuffing box bush (35000).

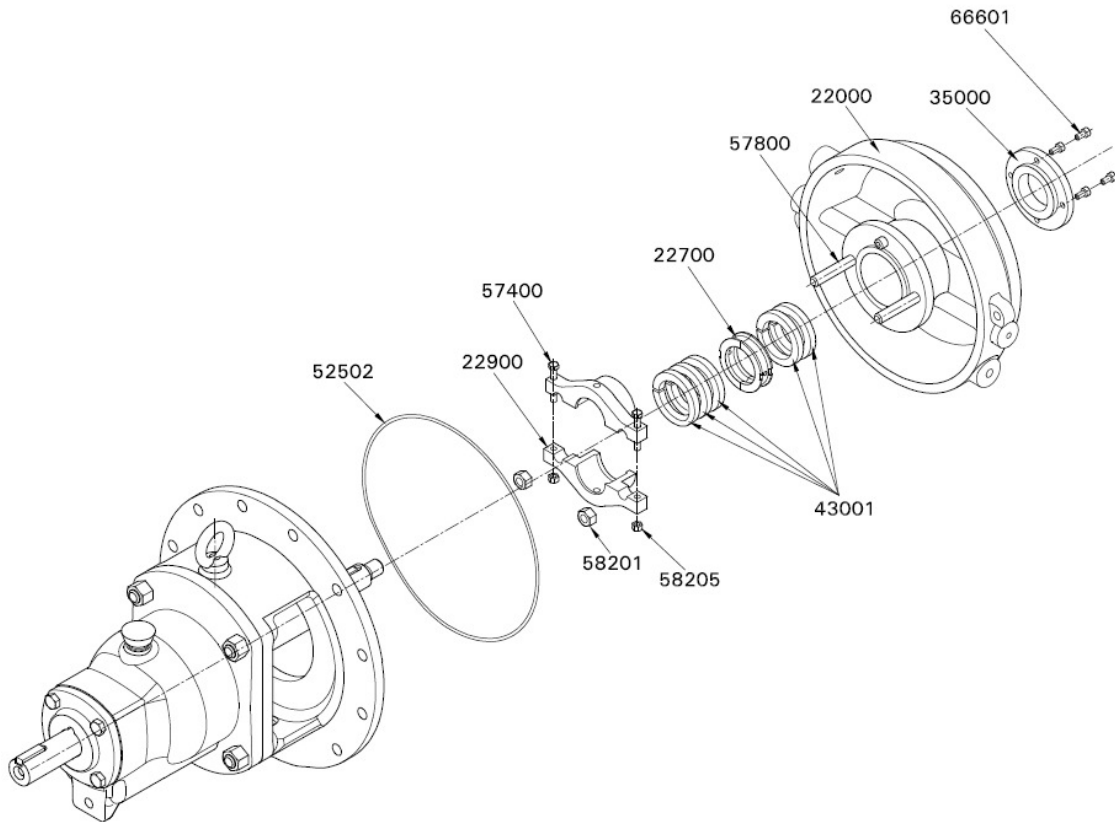

Fig. 14. Removal of stuffing box bush, gland, gland packing & lantern ring

- e) Remove gland packing rings (43000) and lantern ring (22700).
- f) Remove shaft sleeve (31100) along with liquid deflector (23600).

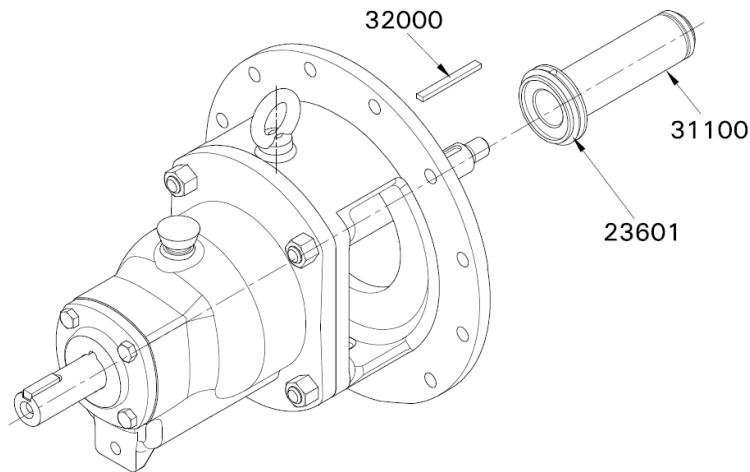

Fig. 15 Removal of sleeve and deflector

- g) Remove impeller key.

5.2.1.1.19 **A) Removal of single mechanical seal from stuffing box:**

For this, following steps should be taken – (Refer mechanical seal drawing)

- a) Remove auxiliary piping connections viz. sealing, flushing, of mechanical seal cover.
- b) Before any action to be taken for cartridge seal removal, **FIRST SLIDE THE SLIDING WASHERS AND ENGAGE THEM IN THE GROOVE ON DRIVE COLLAR FIRMLY.**
- c) Remove Impeller from rotating unit.
- d) Remove Stuffing box bush (35000) from casing cover (22000) by removing cap screws.
- e) Remove hex. nuts from casing cover (22000) studs holding the cover of mechanical seal.
- f) Then remove Casing cover (22000) from rotating unit.

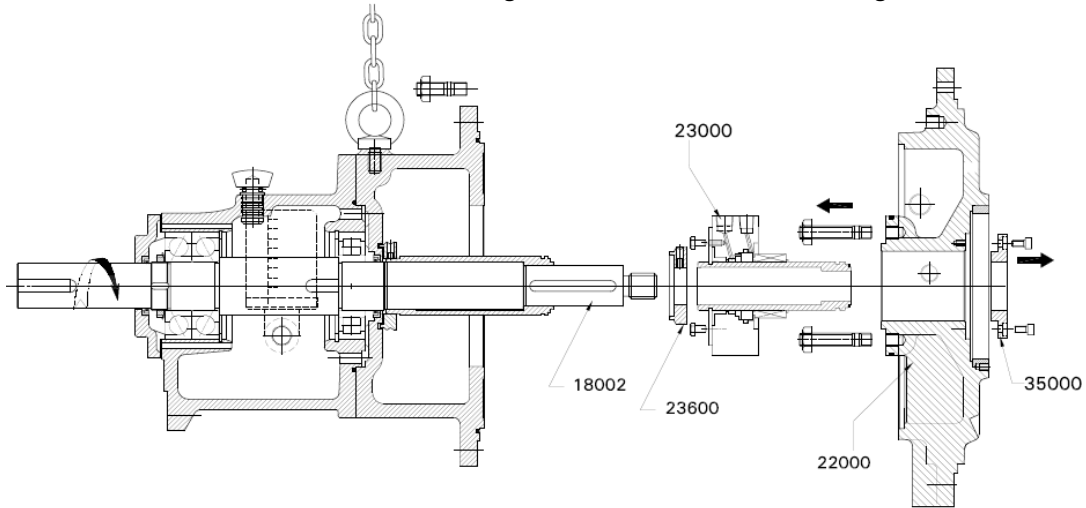

*Fig. 16 Removal of mechanical seal*

- g) Remove Cartridge seal assembly from shaft.
- h) Loosen grub screw holding the liquid deflector (23600). Take out liquid deflector.

**B) Removal of Double mechanical seal from stuffing box:**

For this, following steps should be taken – (Refer mechanical seal drawing)

- i) Remove auxiliary piping connections viz. sealing, flushing, of mechanical seal cover.
- j) (Refer- mechanical seal drawing) Remove Mating ring carrier Inboard (IB) along with mating ring (IB) from casing cover (22000) by removing cap screws.
- k) Remove IB mating ring from mating ring carrier and keep aside.
- l) Remove sleeve alongwith rotating seal ring assemblies (IB & OB).
- m) Remove seal ring assemblies IB & Outboard (OB) from sleeve by loosening screws and keep them such that IB & OB seal ring assembly can be identified easily.

- n) Then remove Casing cover (22000) alongwith gland from rotating unit.
  - o) Remove hex. nuts from casing cover (22000) studs holding the gland (seal cover) of mechanical seal.
  - p) Remove gland from casing cover & then remove OB mating ring from gland and keep aside.
  - q) Check the condition of sleeve, mating ring / seal ring faces, packings, o-rings & replace them if necessary. Handle all seal parts with care; they are manufactured to precise tolerances.
  - r) Loosen grub screw holding the liquid deflector (23600). Take out liquid deflector.
- 5.2.1.1.20 Remove impeller key (32000)
- 5.2.1.1.21 Remove the nuts holding the lantern bracket (24800) and bearing housing (24000).
- 5.2.1.1.22 Take out lantern bracket (24800).
- 5.2.1.1.23 Take out 'o' ring for bearing housing (52310) carefully.

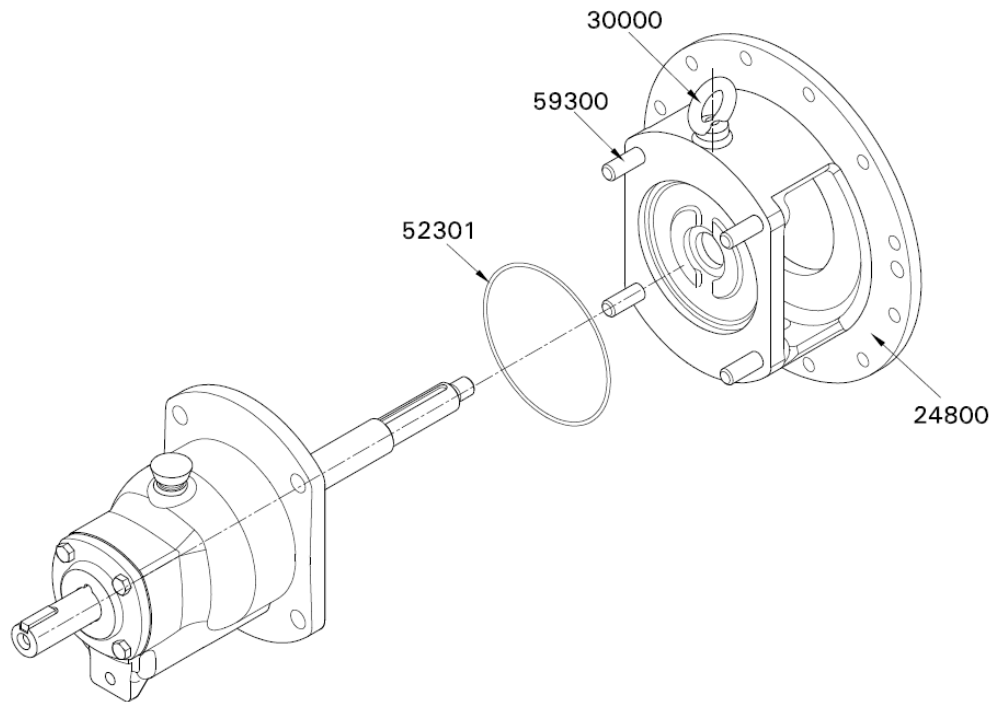
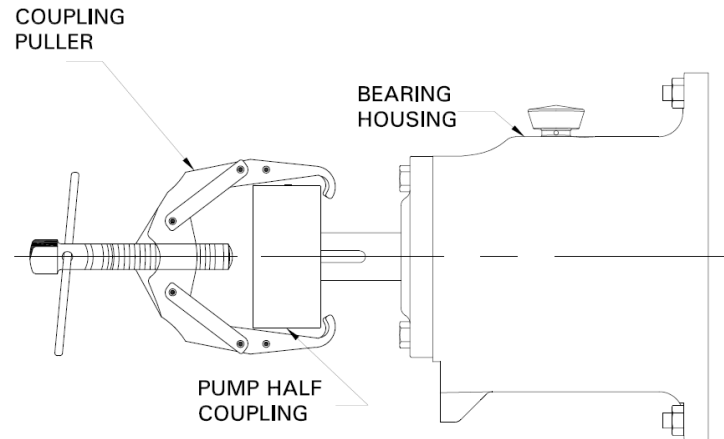

Fig. 17. Removal of Lantern bracket & 'O'ring

- 5.2.1.1.24 Remove pump half coupling (39700) after unscrewing grub screw.

**Caution**

Coupling half should be removed with the help of suitable extraction device. To avoid damage to the bearings, coupling half should not be knocked out of shaft.



*Fig. 18 Removing coupling half from driving end*

- 5.2.1.1.25 Take out coupling key (32100).
- 5.2.1.1.25.1 Loosen the bolts holding bearing cover (27000) (driving end)  
Remove carefully bearing cover along with the oil seal (50001) if applicable. In Labyrinth type sealing arrangement at DE side first remove labyrinth type liquid deflector from shaft & then follow above procedure.
- 5.2.1.1.26 Take out the gasket (51400).

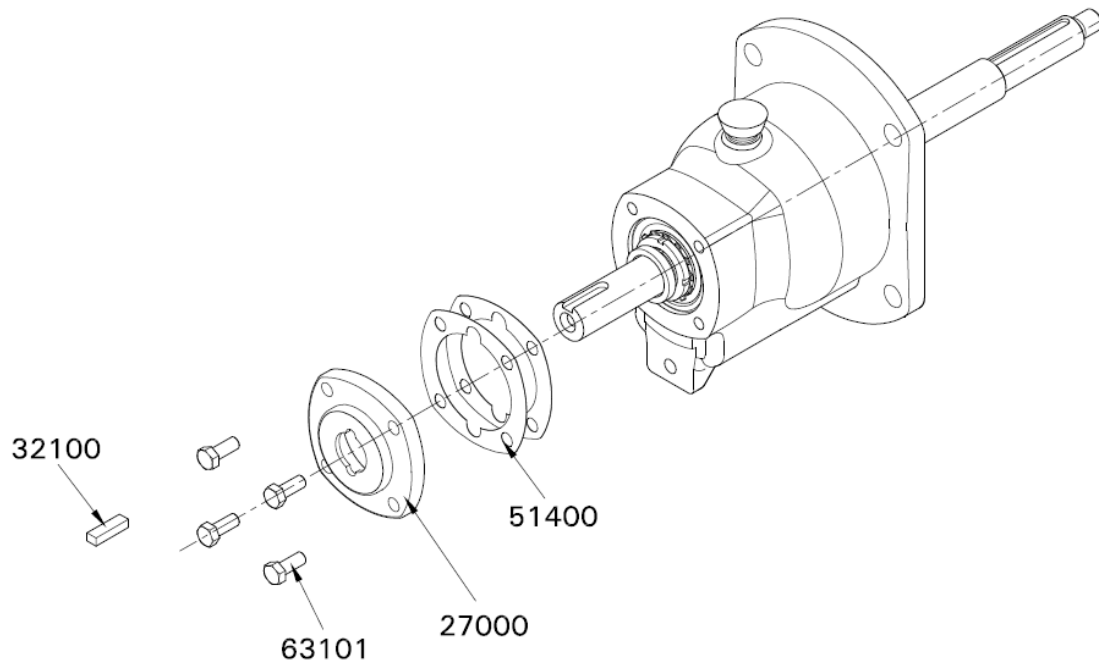

*Fig. 19 Removal of bearing cover & gasket*

- 5.2.1.1.27 Force shaft (18001 / 18002) carefully in the direction of driving end. Shaft will come out along with the bearings.
- 5.2.1.1.28 Unlock the lock washer (41500) and remove lock nut.
- 5.2.1.1.29 Take out the driving end bearing (26300) with the help of puller.

- 5.2.1.1.30 Take out inner race of roller bearing at non-driving end (26400) with the help of suitable sleeve.
- 5.2.1.1.31 Take out outer race of the roller bearing at non-driving end from bearing housing.

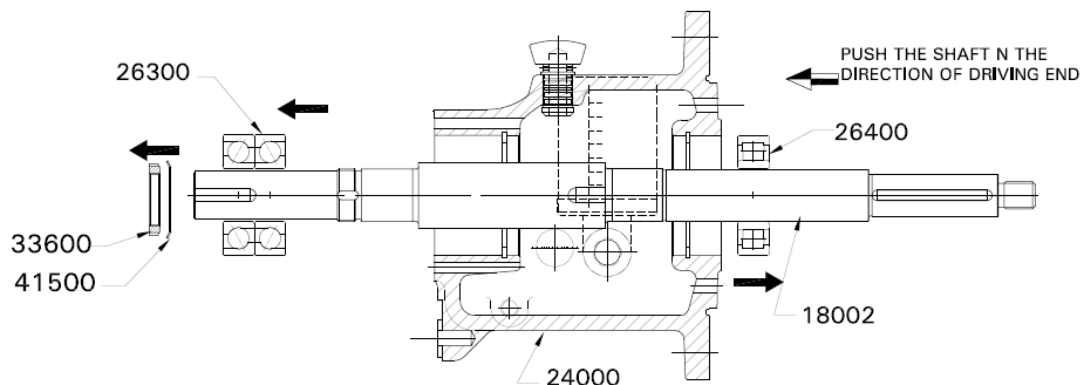

Fig. 20. Dismantling the bearings from bearing housing

**Caution**

- 1) Push the sleeve on arbour press with uniform pressure.
- 2) Steps 5.3.1.1.28 to 5.3.1.1.31 are to be followed only if bearings are damaged and to be replaced.

- 5.2.1.1.32 Oil seal in the driving end bearing cover (50001) should be removed if the oil seal lips are worn out or spring has lost tension.
  - 5.2.1.1.33 Take out circlips (48500) at driving end and non-driving end fitted in bearing housing, if found damaged.
  - 5.2.1.1.34 Casing ring suction side (19000), casing ring delivery side (19100) are to be removed only, if they are worn out and need replacement.
- In case of pump with semi-open impellers**
- 5.2.1.1.35 Remove wear plate (46000) if required. Wear plate is fixed to pump casing and it should not be taken out unless it is to be replaced. Wear plate is press fitted to pump casing and hence it will have to be machined out on center lathe to take it out.
  - 5.2.1.1.36 Change wear plate (46000) if worn out.

**For pumps with bearing housing cooling arrangement, following steps should be followed to dismantle the cooling arrangement.**

- 5.2.1.1.37 Take out cover for bearing housing cooling arrangement (36700) along with copper tube coil (37000) by loosening the screw.
- 5.2.1.1.38 Take out Gasket (68500).

For CLM pumps:

- 5.2.1.1.39 The Procedure of dismantling KPD Centre line mounted pump is same upto step no. 5.2.1.1.38
- 5.2.1.1.40 Remove the pedestal cooling pipings by loosening the union joint.
- 5.2.1.1.41 Remove the pump casing from the pedestals by removing the hex screw between pump casing and CLM pads.

#### 5.2.1.1 RE-ASSEMBLY :

This procedure covers re-assembly of pump after complete dismantling of the pump. Before re-assembly, all the parts should be thoroughly cleaned in kerosene, petrol or benzene to remove the dust, rust etc. After cleaning the necessary parts should be replaced.

- 5.2.1.2.1 Mount the pair of angular contact ball bearings back to back (26300) at driving end. Please refer to any standard bearing catalogue for back-to-back arrangement of angular contact ball bearings. (The arrangement is as shown in figure).

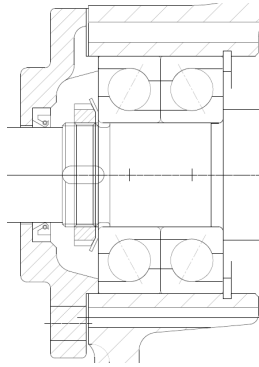

*Fig. 21 Back to back arrangement of Angular contact bearings at DE end*

- a) Use arbour press while fitting the bearings. However it is recommended that bearings should be heated in oil bath at temperature 70 to 80°C and then fitted. (If hot oil bath is not available then ARBOUR PRESS must be used).  
**Use gloves while fitting bearings from hot oil bath.**
  - b) Slide inboard bearing on shaft by hand; make sure that it is square with shaft. Press evenly the inner race of the bearing until bearing is seated firmly against the shaft shoulder.
  - c) Don't use hammer to fit the bearings. Do not damage the shaft surface especially where it is in contact with oil seal.
- 5.2.1.2.2 Mount at non-driving end side of shaft the inner race of roller bearings (26400). Follow the procedure and watch the cautions given in 5.2.1.2.1.
  - 5.2.1.2.3 Push outer race of roller bearing (26400) at non-driving end in to bearing housing (24000).



- 5.2.1.2.4 Tighten bearing lock nut (33600) after inserting washer for bearing locking in proper position. Fold one lip of lock washer in slot of bearing lock nut to lock it.
- 5.2.1.2.5 Insert circlips at driving end (48500) in the grooves of the bearing housing (24000 / 24200). Check returning duct holes in bearing housing and bearing cover at driving end are clean.
- 5.2.1.2.6 Insert shaft (18001 / 18002) along with bearings (viz. angular contact bearings at driving end and inner race of roller bearing at non-driving end) in to the bearing housing from driving end.
- 5.2.1.2.7 Replace oil seals (if applicable) in bearing cover (27000) if they are removed.
- 5.2.1.2.8 Put gasket (51400) of bearing cover at driving end (27000) and tighten bearing cover (27000) with the aid of hexagonal headed screws. Fix DE side labyrinth liquid deflector on shaft with grub screw over DE bearing cover.
- 5.2.1.2.9 Place 'O' ring (52300) on bearing housing (24000). Lubricate 'O' ring with grease or with an 'O' ring lubricant before placing it on the bearing housing.
- 5.2.1.2.10 Mount lantern bracket (24800) on bearing housing (24000) and tighten the nuts.
- 5.2.1.2.11 Put the drip pan (22600) if it was removed from lantern bracket. (if applicable)
- 5.2.1.2.12 For pumps with gland packing arrangement, follow the instructions given below.
- Mount liquid deflector (23601) on shaft sleeve (31100) with the help of grub screws (65400).
  - Apply some oil or grease on the shaft under sleeve position. Mount impeller key (32000) on the shaft and insert shaft sleeve (31100) along with deflector (65400) mounted on it.
  - Fit the hex socketted screw clamped on stuffing box bush (35000) to casing cover (22000).
  - Insert gland packing (43000) and lantern ring (22700) in order of 2 rings first, then lantern ring and finally 3 ring joints should be staggered in casing cover.
  - Put gland in two halves (22900), clamp them with gland bolts (57400). Tighten gland stud nuts on casing cover.

**Caution**

New packing has to be run-in and it is good practice to start the pump with the stuffing box gland quite loose. Packing that is too tight in the box will cause undue friction, creating heat which will glaze the packing and possible score the shaft sleeves. To be effective, the packing must remain soft and pliable. If stuffing box friction is so great that the pump shaft cannot be turned by hand, the box is not properly packed.

- 5.2.1.2.13 For fitting cartridge type single mechanical seal, follow the instructions given below –(Refer mechanical seal drawing)
- Mount deflector (23600) on shaft (18002).





- b) Mount impeller key (32000) on the shaft.
- c) Take the complete cartridge from its package. Do not disassemble or alter the unit. Gently insert assembly of the cartridge on the shaft and let it rest on shaft.

***IMPORTANT: While sliding the cartridge assembly, ensure the sleeve slides forward easily to avoid the seals getting over compressed and damaged. Do not give jerks to the assembly, which may damage the mating ring. While sliding the complete assembly do not hammer on the gland. Apply grease or oil on the shaft while sliding the assembly. This will ease the sliding of O-ring.***

- d) Then put casing cover (22000) & guide it into the lantern bracket (24800) over the shaft.
- e) Fix stuffing box bush (35000) with the help of cap screw in casing cover.
- f) Tighten the mechanical seal cover with casing cover stud only finger tight. Do not distort the gland by over tightening.
- g) Put the impeller (15100) over shaft and rest it on shaft sleeve face. Complete the pump assembly.
- h) Then loosen the bolt hex head of sliding washers and then offset it so as to clear the slots in the drive collar. Then tighten the hex bolts completely to avoid falling of sliding washers and rubbing on drive collar in running condition.
- i) Connect the auxiliary piping connections viz. sealing, flushing of mechanical seal cover.

For fitting double mechanical seal, follow the instructions given below – (Refer mechanical seal drawing)

- j) Mount deflector (23600) on shaft (18002).
- k) Mount impeller key (32000) on the shaft.
- l) Identify & take the Inboard (IB) & Outboard (OB) seal ring assemblies.
- m) Mark in the sleeve location of inboard and outboard seal ring assemblies with respect to casing cover guide diameter as shown on the drawing based on operating length as specified on the drawings.
- n) Mount / fix seal ring IB & OB assemblies on marked location. Apply lightly grease or oil on sleeve to slide seal ring assembly.
- o) Install Inboard o-ring, gasket, mating ring in inboard mating ring carrier at location as shown in drawing. Similarly install out board o-ring, gasket, mating ring in the gland plate at location as shown in drawing.
- p) Apply lightly grease on gasket / 'O' ring of the gland / mating ring carrier to prevent them to fall off.
- q) Mount gland along with mating ring carrier (OB) on casing cover studs keeping in view the barrier fluid outlet direction as shown in drawing. Tighten the gland with casing cover stud. Do not distort the gland by over tightening.
- r) Place 'O' ring (52501) on casing cover (22000) after lubricating it properly. Then put casing cover (22000) & guide it into the lantern bracket (24800) over the shaft.
- s) Slide seal sleeve assembly on the shaft.

**IMPORTANT: While sliding up the seal sleeve assembly, ensure the sleeve slides forward easily to avoid the seals getting over compressed and damaged.**

- t) Mount mating ring carrier (1B) in casing cover & tight the same with the help of cap screws.
- u) Put the impeller (151) over shaft and rest it on shaft sleeve face keeping in between gasket as shown in drawing. Then follow procedure from 5.2.1.2.17

**For reassembly of the bearing housing cooling arrangement follow steps given below.**

- a) Fit the oil well cover for bearing housing cooling arrangement (36700) along with cooling tube coil (37000) with Gasket (685) in between and tighten screws.

- 5.2.1.2.14 Place 'O' ring (52501) on casing cover (22000) after lubricating it properly.
- 5.2.1.2.15 Insert casing cover (22000) with 'O' ring (52502) on Driving unit & lantern bracket assembly. Tighten nuts on studs of casing cover.
- 5.2.1.2.16 Put gasket (51500) on impeller hub in proper position.
- 5.2.1.2.17 Push impeller (15300) on shaft till it touches the shaft sleeve.
- 5.2.1.2.18 Fix the impeller nut (33000) along with helicoil insert (47900) with gasket in between impeller hub and impeller nut and gradually tighten it.

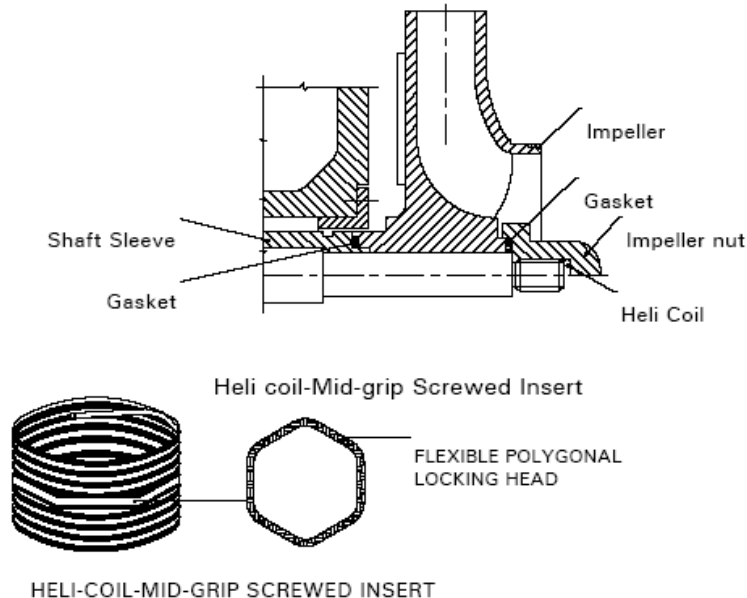

Fig. 22 Helicoil Insert

This will complete back pull out assembly.

- 5.2.1.2.19 In case of KPD-QF pumps only, following procedure is to be followed.

- a) If wear plate is removed and is to be replaced, this should be done very carefully. Apply the pressure on the portion shown in diagram

shown below; otherwise the wear plate may warp. Use of arbour press is recommended.

After tilting of wear plate, measure distance 'X' and ensure that it is within  $\pm 0.1$  mm along the entire periphery of wear plate. It is recommended that wear plate together with casing be

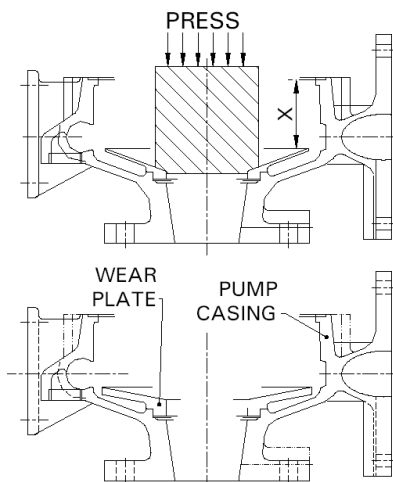

drilled and

*Fig. 23 Fitment of wear plate in KPDQF pump*

tapped to fit minimum two no. of countersunk head screws to prevent rotation of wear plate during actual pump operation.

- 5.2.1.2.20 Rotating unit - General assembly procedure for all pumps
- a) Slide complete, back pull out assembly into pump casing. (10500/10600)
  - b) Tighten all the nuts on casing studs firmly and evenly.

**Caution**

In case of KPD-QF pumps, Clearance between impeller and wear plate is recommended to be 0.3 to 0.5 mm as hydraulic performance of pump depends upon this clearance. If clearance is more head capacity of the pump drops down. Adjust the telescopic arrangement to maintain clearance between impeller and wear plate.

- 5.2.1.2.21 Fit constant level oiler (44300), Breather cap (44400) & support foot (25100) to bearing housing.
- 5.2.1.2.22 Fit pump half coupling (39700).
- 5.2.1.2.23 Rotate shaft by hand and ensure free rotation.
- 5.2.1.2.24 Fit all accessories such as sealing and flushing liquid, cooling water connection, hot water/ steam circulation, safety guard etc.
- 5.2.1.2.25 Fit coupling spacer between pump half and motor half coupling in case of spacer type flexible couplings.
- 5.2.1.2.26 Mount motor on the base in case of standard flexible coupling and align the unit.
- 5.2.1.2.27 Fit coupling guard.

## SPECIAL IMPORTANT INSTRUCTIONS

- 1) The instructions given in this book are of general nature. This manual is to be read in context with C/S (cross-sectional) drawing supplied against order.
- 2) In case of mechanical seal arrangement, KBL invariably supply C/S (cross-sectional) drawing indicating mechanical seal arrangement. This drawing should be referred while commissioning of pumps and carrying out any maintenance work.
- 3) In case of KPD-J and KPD QF-J pumps, the steam/hot water circulation to casing and casing cover should be started well in advance to actual start of the pump. Pump should be started only after ensuring that the liquid inside the casing and suction line is in liquid form. Check free rotation of pump shaft prior to starting of the pump.
- 4) Pumps in all **CN 7MS** material of construction and with K-monel shaft are supplied with impeller nut in two parts i.e. impeller nut and lock nut arrangement as shown in the figure.

While fitting impeller nut in this case ensure the following.

- a) Tighten nut 'A' (impeller lock nut) fully.
- b) Tighten nut 'B' (impeller nut) fully.
- c) Hold nut 'B' firmly in position and slightly loosen nut 'A'. This will ensure positive locking of impeller nuts.

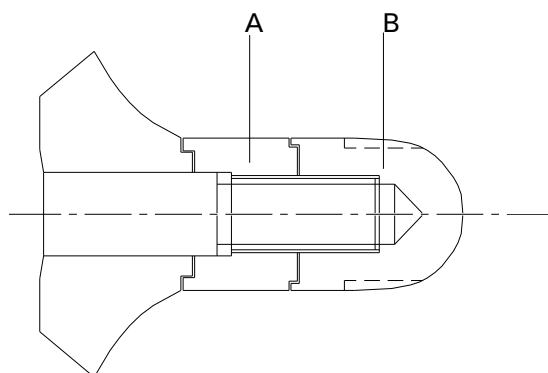

*Fig. 24 Impeller nut and lock nut arrangement*

- 5) Impeller nut (33000) together with helicoil mid grip insert should be treated as one part only. Please do not try to take out helicoil mid grip insert out of impeller nut. If helicoil mid grip insert is damaged, please replace impeller nut by new one. Spare impeller nut is always supplied with helicoil mid grip insert duly fitted in it.

- **Maintenance tools required:**

No special tools are required for dismantling and reassembling. Toolbox containing a general set of tools such as different size ring spanners, torque wrenches, open ended spanners, light ball peen hammer, wooden



mallet, various sizes Allen keys etc serves the purpose. It is important to ensure that the suitable lifting equipment is available and that the work is carried out in clean area.

### **5.3 PREVENTIVE MAINTENANCE:**

Preventive maintenance schedule is the periodical checks and precautions by which possibilities of failures and breakdowns are minimized.

#### **5.3.1 Daily checks:**

- 5.3.1.1 Hourly record of suction and delivery pressure, discharge quantity input to the pump driver should be maintained.
- 5.3.1.2 Bearing temperature, oil level, stuffing box leakage / stuffing box temperature, cooling water inlet and outlet temperature should be checked. This gives an idea of mechanical performance of the pump.
- 5.3.1.3 Noise and vibrations are the first signs of impending troubles like cavitations, air lock, bearing failure, choking of impeller or casing and such other operating troubles. The pump performance should therefore be checked for noise and vibrations.

#### **5.3.2 Periodical checks:**

- 5.3.2.1 The temperature of the bearing should be measured by thermometer. Safe maximum working temperature of the bearing is 80°C.
- 5.3.2.2 The lubricants of the bearing should be checked. The lubricant might get contaminated with foreign material or get blackened due to overheating. In such cases, bearings should be flushed and charged with fresh lubricants.
- 5.3.2.3 Check for the stuffing box leakage. If the pumps are fitted with mechanical seal, there should not be any product leakage from stuffing box.
- 5.3.2.4 The alignment of the pump unit should be checked. Due to operational vibrations, atmospheric temperature or stress induced by the weight of the piping, the alignment may get disturbed.
- 5.3.2.5 Sufficient quantity of suitable type of lubricant should be ready for daily and emergency use.
- 5.3.2.6 Calibrate the measuring instrument.

#### **5.3.3 Annual checks:**

- 5.3.3.1 The pump should be overhauled completely to check the clearance and to replace worn-out parts. Clearance between impeller and casing rings, clearance between impeller and wear plate, shaft sleeves and stuffing box bush, lantern ring and shaft sleeve etc are very important. The bearings should be cleaned thoroughly and lubricated.
- 5.3.3.2 The effects of liquid handled on pump components should be checked. If abnormal corrosion, erosion is observed, the component should be replaced with that of suitable material.
- 5.3.3.3 The auxiliary pipelines and functioning of the auxiliary system should be checked. The main pipe also should be checked for scaling, leakage etc.



- 5.3.3.4 The measuring instruments, gauges etc should be recalibrated.
- 5.3.3.5 Full running test may be carried out to check whether there is any fault in the performance, in comparison with original performance.
- 5.3.3.6 Piping supports should be checked so that the pipes do not induce unwanted stresses on the pump.

#### **5.3.4: Mechanical seal in pump:**

The mechanical seal is a precision product having been subjected to quality control throughout all stages of manufacture. The seals are designed to accommodate reasonable tolerances in the equipment, however in order to obtain the maximum life with trouble free performance, the equipment should be adequately maintained.

When mechanical seal is functioning satisfactorily without any leakage, the preventive maintenance is not advocated. If leakage occurs, a through check up is needed. While fitting the mechanical seals in the pump initially by KBL, due care is taken for its proper fitment.

Like other parts in the equipment the mechanical seals are subject to wear at the mating faces of the rotating and stationary ring. The rate of wear will differ with the operating conditions and various other factors such as lubricating property of the liquid pumped, the presence of impurities in liquid and other operating conditions. In view of this no firm recommendations can be given for renewal of seal rings / complete seals.

KPD pumps are supplied with cartridge type factory assembled mechanical seals and no further operating length adjustments are required.

**Flushing:** Flushing at the mechanical seal faces is necessary to provide lubrication, cooling of the seal faces and hence pump should not be run without flushing at the seal faces. Please refer mechanical seal assembly drawing for flushing liquid pressure and temperature.

**Throttle bush:** Throttle bush is pressed in mechanical seal cover. This bush gives protection in case of seal's failure. Due to close clearance between bush and the shaft sleeve, if the seal fails, the pressure of the product is reduced before it escapes. This bush also minimizes the quench leakage along the shaft. To avoid possibility of the sparking, the bush is made of non-ferrous materials as per API 610 specifications.

## **5.4 CORRECTIVE MAINTENANCE**

### **PUMP TROUBLE**

When investigating trouble with Kirloskar pumps, always remember that pumps have been tested at the factory and are mechanically correct when sent out. Discounting the possibility of damage during transit, most of the trouble in the field is due to faulty installation. Investigation shows that the



majority of troubles with centrifugal pumps result from faulty conditions on the suction side.

### BREAK DOWN-CAUSE-CHECK POINTS

In case of breakdown we recommend the location of the fault by referring the table for 'Break Down Check Points' given at the end of this manual.

### 6.0 TECHNICAL DATA:

#### 6.1 Direction of rotation:

The direction of rotation is clockwise when viewed from driving end.

#### 6.2 Specification of oil seal and quantity of oil.

| Sr. No | Description                                      | Unit no.  |           |           |           |           |           |           |
|--------|--|-----------|-----------|-----------|-----------|-----------|-----------|-----------|
|        |  | No 5      | No 7      | No 9      | No 11     | No 13     | No 15     | No 19     |
| 50001  | Oil seal DS                                      | 25x37x7   | 32x45x7   | 72x42x10  | 72x50x10  | 60x85x13  | --        | --        |
|        | *Oil seal PS                                     | 25x37x7   | 35x47x7   | 60x45x8   | 72x50x10  | 65x85x13  | --        | --        |
|        | Quantity of oil in bearing housing (approximate) | 0.4 Liter | 0.5 Liter | 0.7 Liter | 1.0 Liter | 1.5 Liter | 1.8 Liter | 2.5 Liter |

\* supplied against order.

#### 6.3 Bearings:

- Bearings of SKF make or equivalent and with C3 clearance are used.
- Bearings are oil lubricated. Oil level in the bearing housing should be maintained with the help of constant level oiler. Constant level oiler is a standard scope of supply.
- Maximum allowable temperature of bearings: 80°C
- In case of pumping liquids above 180° C, cooling of lubricant oil shall be necessary. Bearing housing cooling arrangement provided, quantity of cooling water required is 0.25 m<sup>3</sup>/hr at 6 kg/cm<sup>2</sup>.
- In case of new bearings, renew the oil after about 200 hours and then about once a year, if the bearing temperature is always below 50°C and there is only small risk of contamination. If the bearing temperature is upto 80°C and if there is danger of contamination, the oil should be renewed about every six months.

#### A) Bearing details for KPD:

| Driving unit no. | Speed in RPM | Bearing size |                 |
|------------------|--------------|--------------|-----------------|
|                  |              | Driving end  | Non driving end |
|                  |              |              |                 |



|     |  |                                   |                      |
|-----|--|-----------------------------------|----------------------|
| 5   | Upto 3000 rpm                                | SKF-7206 BG<br>(2 Nos/1 pair)     | SKF-NU305<br>(1 No.) |
| 7   | Upto 1500 rpm                                | SKF-7307 BG<br>(2 Nos/1 pair)     | SKF-NU307<br>(1 No.) |
|     | Above 1500 and upto 3000 rpm                 | SKF-7307 BG<br>(2 Nos./ 1 pair)   | SKF-NU307<br>(1 No.) |
| 9   | Upto 3000 rpm                                | SKF-7309 BG<br>(2 Nos./ 1 pair )  | SKF-NU309<br>(1 No.) |
| 11  | Upto 3000 rpm<br>(only for 125/26 @2900 rpm) | SKF-3311<br>(1 No.)               | SKF-NU311<br>(1 No.) |
| 11A | Upto 1750 rpm                                | SKF-7311 BECB<br>(2 Nos/ 1 pair)  | SKF-NU311<br>(1 No.) |
| 11B | Upto 1750 rpm                                | SKF-7311 BECB<br>(2 Nos/ 1 pair)  | SKF-NU311<br>(1 No.) |
| 11C | Upto 1750 rpm                                | SKF-7311 BECB<br>(2 Nos/ 1 pair)  | SKF-NU311<br>(1 No.) |
| 13  | Upto 1500 rpm                                | SKF-7313 BG<br>(2 Nos/ 1 pair)    | SKF-NU313<br>(1 No.) |
| 15  | Upto 1500 rpm                                | SKF-7315 BECBP<br>(2 Nos/ 1 pair) | SKF-NU413<br>(1 No.) |
| 19  | Upto 1500 rpm                                | SKF-7319 BECBM<br>(2 Nos/ 1 pair) | SKF-NU416<br>(1 No.) |

**B) Bearing details for KPD-QF (i.e. semi-open impellers)**

| Driving unit no. | Speed in RPM  | Bearing arrangement | Bearing size                                 |                      |
|------------------|---------------|---------------------|--|----------------------|
|                  |               |                     | Driving end                                  | Non-driving end      |
| 4                | Upto 3000 rpm | Standard supply     | SKF-6304<br>(1 No.) &<br>SKF-7304<br>(1 No.) | SKF-6304<br>(1 No.)  |
| 5                | Upto 3000 rpm | Standard supply     | SKF-7206 BG<br>(2 Nos./ 1 pair)              | SKF-NU305<br>(1 No.) |
| 7                | Upto 3000 rpm | Standard supply     | SKF-7307 BG<br>(2 Nos./ 1 pair)              | SKF-NU307<br>(1 No.) |
| 9                | Upto 3000 rpm | Standard supply     | SKF-7309 BG<br>(2 Nos./ 1 pair)              | SKF-NU309<br>(1 No.) |



**Notes:**

1. The bearing arrangements mentioned above are suitable for suction pressure less than 5 kg/cm<sup>2</sup>. For applications involving suction pressure above 5 kg/cm<sup>2</sup>, please refer to Unit sales, Kirloskarvadi.
2. Axial running clearance shall be less than 0.45 mm for all above bearing arrangements.

**6.4 Lubrication**

The oil used should be highly refined straight mineral product of high demulsibility, free from running and acid forming tendencies. Detergent oil may cause foaming and emulsion difficulties, hence should not be used. The oil should be filled in with the help of constant level oiler. For fitting and operating instructions, please refer instructions mentioned in this manual. The lubrication oil should confirm to the following grades of oil available in market.

| Manufacturers       | Speed - 1450 rpm  | Speed - 2900 rpm  |
|---------------------|-------------------|-------------------|
| Indian oil          | SERVOSYSTEM 57/68 | SERVOSYSTEM 57/68 |
| Hindustan petroleum | ENKLO-57          | ENKLO-57          |
| Shell               | TELLUS 68         | TELLUS 68         |
| Veedol              | ATLINE 68         | ATLINE 68         |

**6.5 Cooling of stuffing box, bearing housing and pump pads:**

- 6.5.1 Cool the gland packed stuffing box when pumping liquid temperature is above 105° C.
- 6.5.2 Cool the mechanical seal, stuffing box when pumping liquid temperature is above 140° C.
- 6.5.3 Quantity of stuffing box cooling water with respect to temperature and nominal impeller diameter.

| Full nominal impeller dia. in cm | Cooling water quantity at various pumping liquid temperatures m <sup>3</sup> /hr. |        |        |        |        |
|----------------------------------|---|--------|--------|--------|--------|
|                                  | 110° C  | 150° C | 200° C | 250° C | 300° C |
| 13                               | 0.16  | 0.18   | 0.24   | 0.31   | 0.43   |
| 16                               | 0.16  | 0.18   | 0.24   | 0.31   | 0.43   |
| 20                               | 0.16  | 0.18   | 0.24   | 0.31   | 0.43   |
| 26                               | 0.21  | 0.24   | 0.31   | 0.40   | 0.54   |
| 32                               | 0.23  | 0.28   | 0.37   | 0.48   | 0.63   |
| 38/40                            | 0.26  | 0.31   | 0.43   | 0.55   | 0.71   |



Enriching Lives

|       |      |      |      |      |      |
|-------|------|------|------|------|------|
| 46/50 | 0.45 | 0.55 | 0.65 | 0.75 | 1.00 |
| 51/56 | 0.50 | 0.60 | 0.70 | 0.80 | 1.10 |

Maximum temperature of cooling water at outlet = 50° C.  
 Maximum permissible cooling water pressure = 6.0 kg/cm

BASKET AND "O" RING FOR DRIVING UNITS 5,7,9,1,1,13

| KPD 7  |   | KPD 9                            |                         | KPD 11                  |                         | KPD 13                  |           |
|--|---|----------------------------------|-------------------------|-------------------------|-------------------------|-------------------------|-----------|
| UNIT NO.   |   | UNIT NO.                         |                         | UNIT NO.                |                         | UNIT NO.                |           |
| 50/32  | 40/32                                     | 65/43                            | 150/32                  | 125/46                  | 150/52                  | 125/32                  | 12900     |
| 80/26  | 50/26                                     | 150/40                           | 150/40                  | 125/46                  | 150/52                  | 125/32                  | 12900     |
| 65/26  | 50/26                                     | 150/40                           | 150/40                  | 125/46                  | 150/52                  | 125/32                  | 12900     |
| 40/26  | 50/26                                     | 80/40                            | 100/40                  | 125/46                  | 150/52                  | 125/32                  | 12900     |
| 20/26  | 50/26                                     | 100/32                           | 100/32                  | 125/46                  | 150/52                  | 125/32                  | 12900     |
| 15/26  | 50/26                                     | 125/32                           | 100/32                  | 125/46                  | 150/52                  | 125/32                  | 12900     |
| 10/26  | 50/26                                     | 80/32                            | 100/32                  | 125/46                  | 150/52                  | 125/32                  | 12900     |
| 5/26   | 50/26                                     | 65/32                            | 100/32                  | 125/46                  | 150/52                  | 125/32                  | 12900     |
| 2 + L + 3  | 2 + L + 3                                 | 2 + L + 3                        | 2 + L + 3               | 2 + L + 3               | 2 + L + 3               | 2 + L + 3               | 2 + L + 3 |
| 45 x 10 THICK.                                     | 75 x 55 x 10 THICK.                       | 75 x 55 x 10 THICK.              | 75 x 55 x 10 THICK.     | 75 x 55 x 10 THICK.     | 80 x 105 x 12 THICK.    | 55 x 82 x 13 THICK      |           |
| 180  | 205                                       | 205                              | 205                     | 205                     | 295                     | 215                     |           |
| 268 ID x 331 ID x 268 ID x 348 OD x 282 OD x 1 TH. | 331 ID x 411 ID x 348 OD x 282 OD x 1 TH. | 268 ID x 454 ID x 282 OD x 1 TH. | 471 ID x 481 OD x 1 TH. | 402 ID x 480 OD x 2 TH. | 685 ID x 520 ID x 1 TH. | 331 ID x 520 ID x 1 TH. |           |
| 122 x 102 x 118                                    | 124 x 134 x 118                           | 146 x 156 x 118                  | 146 x 156 x 118         | 140 x 184 x 1 TH        | 140 x 184 x 1 TH        | 140 x 184 x 1 TH        |           |
| D x 35 ID x 1 TH                                   | 50 OD x 44 ID x 1 TH                      | 50 OD x 44 ID x 1 TH             | 50 OD x 44 ID x 1 TH    | 69 OD x 74 ID x 1 TH    | 69 OD x 74 ID x 1 TH    | 46 ID x 52 OD x 1 TH    |           |
| D x 94 OD x 1 TH                                   | 76 ID x 94 OD x 1 TH                      | 76 ID x 94 OD x 1 TH             | 76 ID x 94 OD x 1 TH    | 83 ID x 94 OD x 1 TH    | 83 ID x 94 OD x 1 TH    | 145 ID x 3 TH.          |           |
| 23 ID x 3 TH.                                      | 145 ID x 3 TH.                            | 145 ID x 3 TH.                   | 145 ID x 3 TH.          | 175 ID x 3 TH.          | 175 ID x 3 TH.          | 145 ID x 3 TH.          |           |
| 50 ID x 3 TH.                                      | 150 ID x 3 TH.                            | 150 ID x 3 TH.                   | 150 ID x 3 TH.          | 207 ID x 3 TH.          | 207 ID x 3 TH.          | 265 ID x 3 TH           |           |
| 215 ID x 3 TH.                                     | 265 ID x 3 TH.                            | 265 ID x 3 TH.                   | 265 ID x 3 TH.          | 308 ID x 3 TH.          | 308 ID x 3 TH.          | 265 ID x 3 TH           |           |
| 18 ID x 3 TH.                                      | 108 ID x 3 TH.                            | 108 ID x 3 TH.                   | 108 ID x 3 TH.          | 140 x 184 x 1 TH        | 140 x 184 x 1 TH        | 140 x 184 x 1 TH        |           |
| D x 28 ID x 1 TH.                                  | 48 OD x 38 ID x 1 TH.                     | 48 OD x 38 ID x 1 TH.            | 48 OD x 38 ID x 1 TH.   | 69 OD x 56 ID x 1 TH.   | 69 OD x 56 ID x 1 TH.   | 40 ID x 48 OD x 1 TH.   |           |
| D x 55 ID x 1 TH.                                  | 99 OD x 55 ID x 1 TH.                     | 99 OD x 55 ID x 1 TH.            | 99 OD x 55 ID x 1 TH.   | 99 OD x 55 ID x 1 TH.   | 99 OD x 55 ID x 1 TH.   | 99 OD x 55 ID x 1 TH.   |           |
| ID SUITABLE GRADE OF ST. BOX PACKING.              |   |                                  |                         |                         |                         |                         |           |
| VST ORDER.   |   |                                  |                         |                         |                         |                         |           |

ION Paç 29.



## Specification of Stuffing box packing, gasket, O-ring for driving unit 15 and 19

| Part No. | Description                                | KPD unit 15       | KPD unit 19       |
|----------|--|-------------------|-------------------|
|          | Gland packed arrangement with lantern ring | 3 + L + 2         | 3 + L + 2         |
| 430001   | Gland packing size (OD x ID x TH)          | 80 x105 x12 thick | 108x140 x16 thick |
|          | Straight length of gland packing in mm     | 295               | 395               |
| 5110001  | Gasket for casing & casing cover           | 520IDX540ODX2T    | 410IDX430ODX2T    |
| 5140001  | Gasket for Bearing cover                   | 192IDX205ODX1T    | 205IDX245ODX1T    |
| 5150001  | Gasket for impeller & shaft sleeve         | 69 IDX74 ODX1T    | 95 IDX102 ODX1T   |
| 5250101  | O ring for Casing cover                    | 175 IDX3T         | 212 IDX3T         |
| 5231101  | O ring for Bearing housing                 | 207 IDX3T         | 245 IDX3T         |
| 5250201  | O ring for Lantern bracket                 | 328 IDX3T         | 333 IDX3.25T      |
| 5230301  | O ring for Bearing cartridge               | ----              | ----              |
| 6820001  | Gasket for impeller & impeller nut         | 70IDX80ODX1T      | 98IDX86ODX1T      |
| 6850001  | Gasket for Oil well cover                  | 99ODX55IDX1T      | ----              |

**6.8 Cooling to pump pads**

Centerline mounted pumps are supported on pads through which cooling water should be circulated. Centerline mounted pumps are recommended for pumping liquids of temperature above 180° C. Pump with centerline mounted delivery casing is optional.



Quantity of cooling water to pad – 0.2 to 0.3 m<sup>3</sup>/hr.  
Maximum permissible cooling water pressure – 6.0 kg/cm<sup>2</sup>.

- 6.9 Clearance between impeller
- 6.9 Steam or hot water circulation in KPD jacketed pump:  
Before start up the pump hot water circulation should be started through casing jacket, casing cover jacket, and mechanical seal cover (in case of pump with mechanical seal) for a period of minimum half an hour to ensure that all solidified liquid shall melt.
- 6.10 Interchangeability:  
Parts standardization is optimized utilizing interchangeable components to cover a very wide performance. This unique feature enables the customer to have a very low spare parts inventory even though he may have many sizes of these pumps.

#### PART NUMBER AND DESCRIPTION

| Sr. No. | Part no | Description                              |
|---------|---------|--|
| 1       | 10500   | Pump Casing (Foot Mounted)               |
| 2       | 10600   | Pump Casing (Centre Line Mounted)        |
| 3       | 15100*  | Impeller                                 |
| 4       | 15300*  | Semiopen Impeller                        |
| 5       | 18001*  | Pump Shaft Std Brg Arrgt.                |
| 6       | 18002*  | Pump Shaft Reinforced Brg Arrgt.         |
| 7       | 19000*  | Casing Ring (Suction Side)               |
| 8       | 19100*  | Casing Ring (Delivery Side)              |
| 9       | 19200*  | Impeller Ring (Suction Side)             |
| 10      | 19300*  | Impeller Ring (Delivery Side)            |
| 11      | 19800   | Spacer                                   |
| 12      | 19900   | Shoulder Ring                            |
| 13      | 20900   | Spacer Ring                              |
| 14      | 22000   | Casing Cover                             |
| 15      | 22600   | Drip Pan                                 |
| 16      | 22700   | Lantern Ring                             |
| 17      | 22900   | Split Gland                              |
| 18      | 23000*  | Mechanical Seal                          |
| 19      | 23100   | Mechanical Seal Cover                    |
| 20      | 23600   | Liquid Deflector (Mechanical Seal Arrg.) |
| 21      | 23601   | Liquid Deflector (Gland Packed Arrg.)    |
| 22      | 24000   | Bearing Housing                          |



|         |         |  |
|---------|---------|--|
| 23      | 24100   | Bearing Cartridge,Unit-7qf                 |
| 25      | 24800   | Lantern Bracket                            |
| 26      | 25100   | Support Foot                               |
| 27      | 25200   | Bearing Housing (With Cooling Arrg.)       |
| 28      | 26000*  | Deep Groove Ball Bearing (De & Nde)        |
| 29      | 26300*  | Angular Contact Bearing (De)               |
| 30      | 26400*  | Cylindrical Roller Bearing (Nde)           |
| 31      | 27000   | Bearing Cover (De)                         |
| 32      | 27100   | Bearing Cover (Nde)                        |
| 33      | 28501   | Taper Piece (CONCENTRIC)- DEL              |
| 34      | 28501   | Taper Piece (ECCENTRIC)- SUC.              |
| 35      | 30000   | Lifting Eye Bolt                           |
| 36      | 31100*  | Shaft Sleeve (Gland Packed Arrangement)    |
| Sr. No. | Part no | Description                                |
| 37      | 31500*  | Shaft Sleeve (Mechanical Seal Arrangement) |
| 38      | 32000   | Key For Impeller                           |
| 39      | 32100   | Key For Coupling                           |
| 40      | 33000*  | Impeller Nut                               |
| 41      | 33001*  | Impeller Lock Nut                          |
| 42      | 33600*  | Bearing Lock Nut                           |
| 43      | 33601   | Lock Nut For CLM PAD COOLING PIPING        |
| 44      | 35000*  | Stuffing Box Bush                          |
| 45      | 36000   | Quenching Bush                             |
| 46      | 36700   | Oil Well Cover                             |
| 47      | 37000   | Cooling Coil                               |
| 48      | 38401   | Fabricated Pad                             |
| 49      | 41500*  | Lock Washer For Bearing Lock Nut           |
| 50      | 43001*  | Gland Packing                              |
| 51      | 44100   | Grease Nipple                              |
| 52      | 44300   | Constant Level Oiler                       |
| 53      | 44400   | Oil Feeding Plug                           |
| 54      | 45000   | Vent Valve                                 |
| 55      | 46000*  | Wear Plate-QF                              |
| 56      | 47900*  | Helicoil Insert                            |
| 57      | 48500*  | Internal Circlip                           |
| 58      | 49000*  | Flange For Csg Drain                       |
| 59      | 50000*  | Oil Seal D.S                               |
| 60      | 50001*  | Oil Seal P.S.                              |
| 61      | 51101   | Gasket For Csg & Csg Cover                 |
| 62      | 51400*  | Gasket For De Bearing Cover                |
| 63      | 51500*  | Gasket For Sleeve & Imp.                   |



|         |         |   |
|---------|---------|---|
| 64      | 51600*  | Gasket For Mech.Seal Cover                          |
| 65      | 51800*  | Gasket For Adapter And Sealing Connection           |
| 66      | 52301   | O-Ring For Bearing Housing and Lantern Bracket      |
| 67      | 52501*  | O-Ring For C.Cover & Lant. Bracket                  |
| 68      | 52502*  | O-Ring For Lan.Bkt.& Csg.Cover(Hot Model)           |
| 69      | 53101   | Pipe Nipple For Pad Cooling Piping                  |
| 70      | 53102   | Pipe Nipple For Pad Cooling Piping                  |
| 71      | 53200   | Flexible Pipe For Flushing                          |
| 72      | 53301   | Pipe Nipple From Casing To Elbow                    |
| 73      | 53302   | Pipe Nipple From Elbow To Valve                     |
| Sr. No. | Part no | Description   |
| 74      | 53303   | Pipe Nipple From Valve To Flange                    |
| 75      | 54201   | Elbow For Casing Drain                              |
| 76      | 54202   | Elbow For Socket Weld Casing Drain Piping           |
| 77      | 54400   | Reducer   |
| 78      | 54500   | Union Joint For Pad Cooling Piping                  |
| 79      | 55000   | Wheel Cock For Casing Drain Piping                  |
| 80      | 57400   | Hex Bolt For Gland Clamping                         |
| 81      | 57800   | Hex Screw For Gland                                 |
| 82      | 58100   | Hex Nuts For Casing Studs                           |
| 83      | 58201   | Hex Nuts For Gland Studs                            |
| 84      | 58202   | Hex Nuts For Studs Of Mechanical Seal Cover         |
| 85      | 58203   | Hex Nuts For Studs Receiv.Lant.Bkt.& Csg.Cover      |
| 86      | 58204   | Hex Nuts For Brg. Cartridge (For Locking Arrgt.)    |
| 87      | 58205   | Hex Nuts For Hex Bolts Receiving Gland              |
| 88      | 58600   | Hex Nuts For Studs Receiv.Brg.Hsg.& Lant.Bkt.       |
| 89      | 58602   | Hex Nuts For Studs On Pump Casing Flange Suc.& Del. |
| 90      | 59002   | Studs On Casing To Receiv.Csg.Cover & Lant.Bkt.     |
| 91      | 59100   | Studs On Pump Casing To Receive Casing Cover        |
| 92      | 59101   | Studs On Casing Cover To Receive Lant.Bkt.          |
| 93      | 59102   | Studs On Csg.Cover To Receive Split Gland           |
| 94      | 59103   | Studs On Csg.Cover To Receive Mech.Seal Cover       |
| 95      | 59300   | Studs On Lant.Bracket To Receive Brg.Housing        |
| 96      | 60001   | Plug For Pressure Gauge Conn. (Suction Side)        |
| 97      | 60002   | Plug For Pressure Gauge Conn. (Delivery Side)       |
| 98      | 60100   | Plug For Pump Casing Drain                          |
| 99      | 60201   | Plug For Sealing Conn. Of Pump Casing               |
| 100     | 60202   | Plug For Sealing Inlet Conn. Of Csg.Cover           |
| 101     | 60203   | Plug For Sealing In.& Out.Conn.Of Csg.Cover         |
| 102     | 60204   | Plug For External Flushing Conn.                    |
| 103     | 60300   | Pipe plug for cooling                               |



| 104     | 60301   | Plug For Cooling Inlet Conn.On Csg.Cover      |
|---------|---------|---|
| 105     | 60302   | Plug For Cooling Outlet Conn.On Csg.Cover     |
| 106     | 60400   | Plug For Drip Pan                             |
| 107     | 60501   | Plug For Bearing Housing Drain                |
| 108     | 60502   | Locking plug for bearing housing              |
| 109     | 60901   | Plug For Flusing On Mech.Seal Cover (Inlet)   |
| Sr. No. | Part no | Description                                   |
| 110     | 60902   | Plug For Quenching (Inlet & Outlet)           |
| 111     | 63000   | Hex Release Screw For Casing Cover            |
| 112     | 63101   | Hex Screw For De Bearing Cover                |
| 113     | 63102   | Hex Screw For Oil Well Cover                  |
| 114     | 63200   | Hex Screw For Support Foot                    |
| 115     | 64000   | Rivets For Name Plate                         |
| 116     | 64001   | Hammer Drive Screw                            |
| 117     | 65001   | Grub Screw For Csg.Ring & Imp.Ring (Suc.Side) |
| 118     | 65002   | Grub Screw For Csg.Ring & Imp.Ring (Del.Side) |
| 119     | 65400   | Grub Screw For Liquid Deflector               |
| 120     | 66601   | Hex Socketed Cap Screw For Stuffing Box Bush  |
| 121     | 66602   | Socketed Grub Screw For Casing Cover          |
| 122     | 66603   | Hex Socketed Grub Screw                       |
| 123     | 66604   | Hex Socketed Head Cap Screw                   |
| 124     | 67000   | Duty Name Plate                               |
| 125     | 67101   | CoOling Water Name Plate (Inlet)              |
| 126     | 67102   | CoOling Water Name Plate (Outlet)             |
| 127     | 67105   | Steam Inlet Nameplate                         |
| 128     | 67105   | Steam Outlet Nameplate                        |
| 129     | 67200   | Direction Of Rotation Arrow Name Plate        |
| 130     | 67601   | Sealing Water Name Plate (Inlet)              |
| 131     | 67602   | Sealing Water Name Plate (Outlet)             |
| 132     | 67900   | Quenching Name Plate (Inlet)                  |
| 133     | 67901   | Quenching Name Plate (Outlet)                 |
| 134     | 68200*  | Gasket Betw.Impeller Nut & Impeller Lock Nut  |
| 135     | 68201*  | Gasket Between Impeller & Impeller Nut        |
| 136     | 68500*  | Gasket For Oil Well Cover                     |
| 137     | 70100   | Spring Washer For Support Foot                |
| 138     | 71500   | Hex Screw For Pad                             |
| 139     | 71700   | Hex Screw For Clm Pad & Pump Casing           |
| 140     | 72700   | Locking Plug For Clm Pad Cooling              |
| 141     | 78100   | Flushing Name Plate (Inlet)                   |
| 142     | 78101   | Flushing Nameplate (Outlet)                   |



Enriching Lives

1. KPD32/13, 50/13

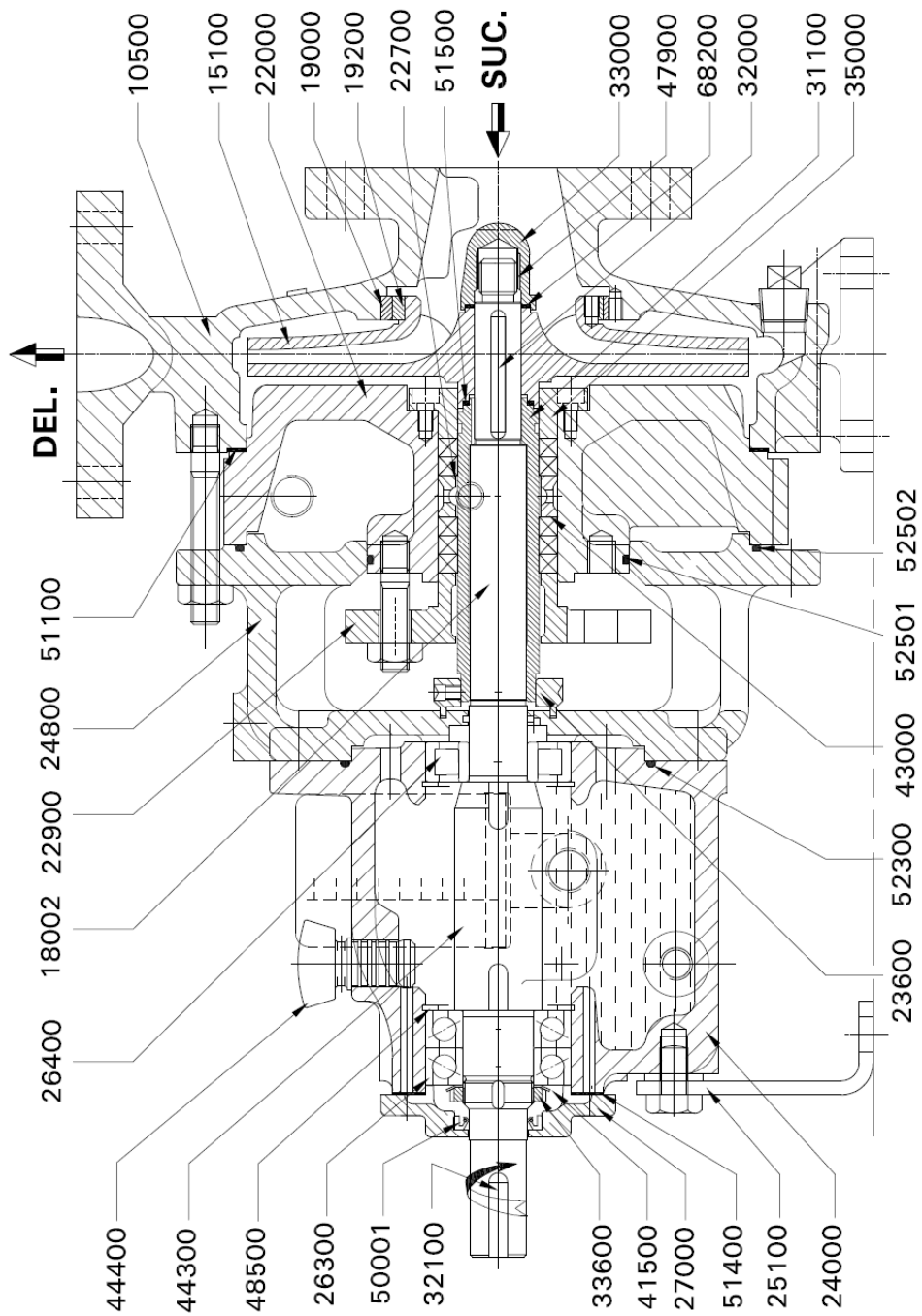





2. KPD32-80/16,32-100/20,32-125/26 (Lifting eye bolts supplied only for KPD32-125/26)

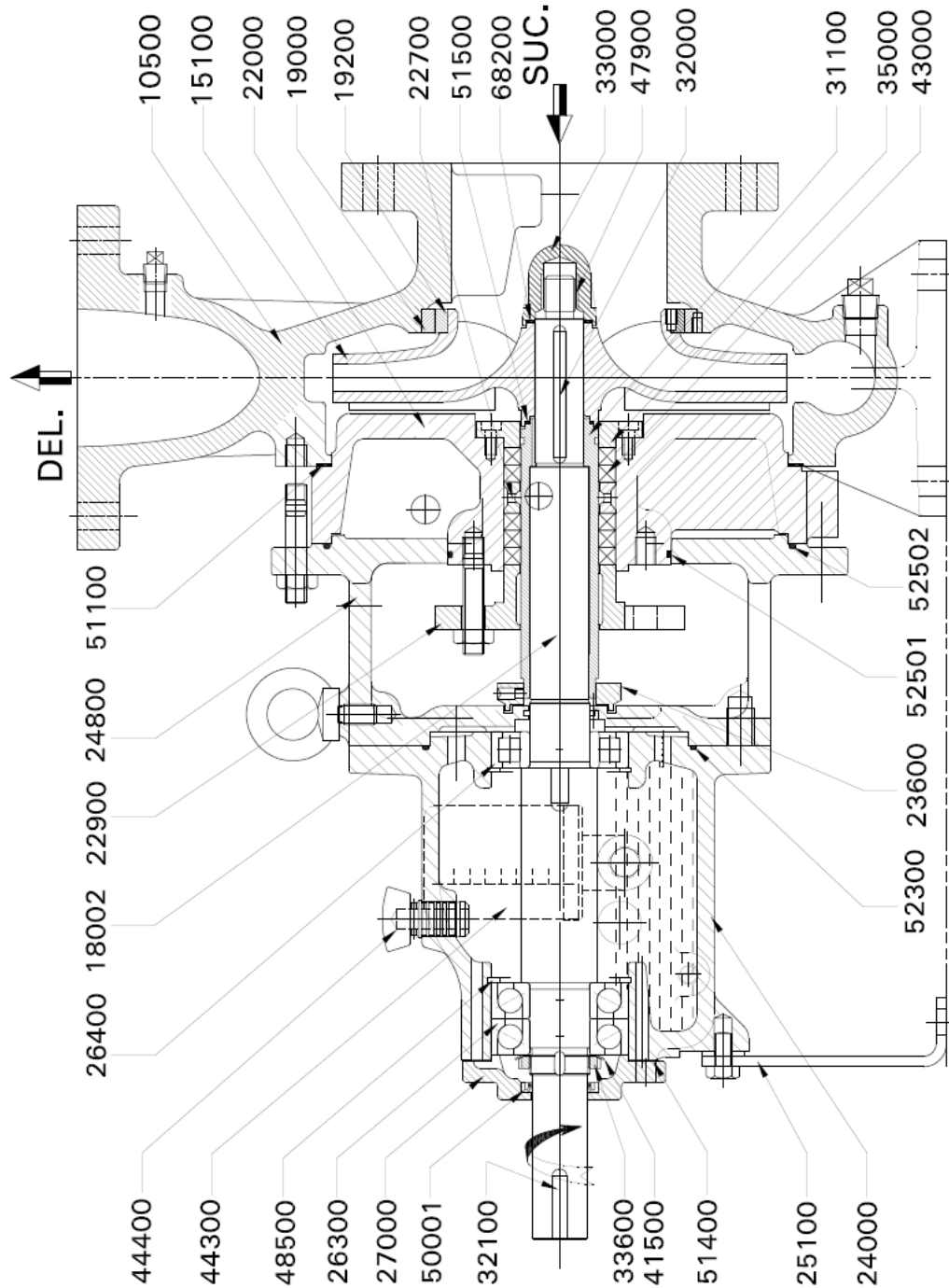

3. KPD40-150/32,80-150/40,KPD65/43,KPD125/45,KPD150/43,KPD150/52  
KPD200/38M, KPD200/46



Enriching Lives

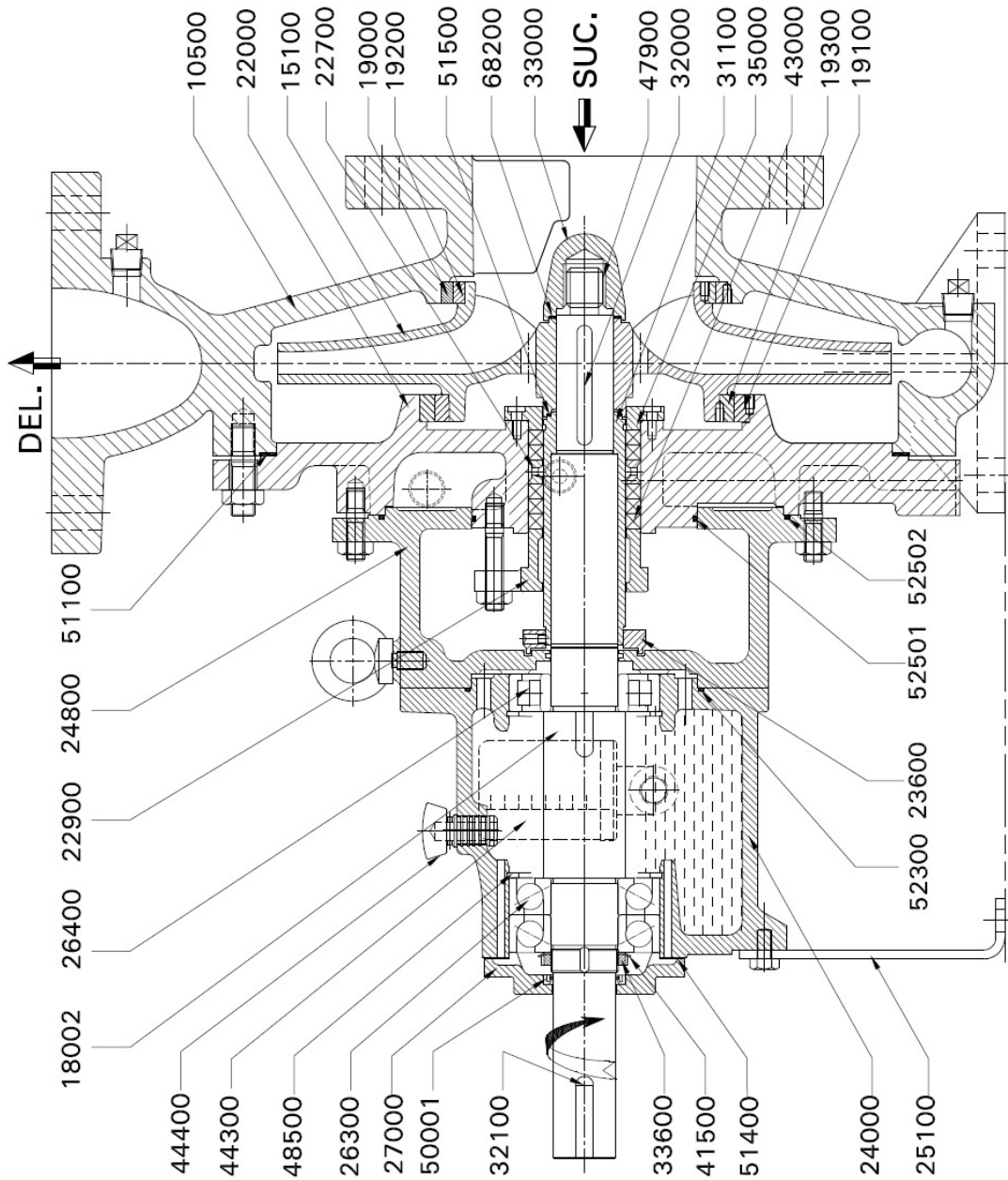

4. KPD125/26 at 2900 rpm

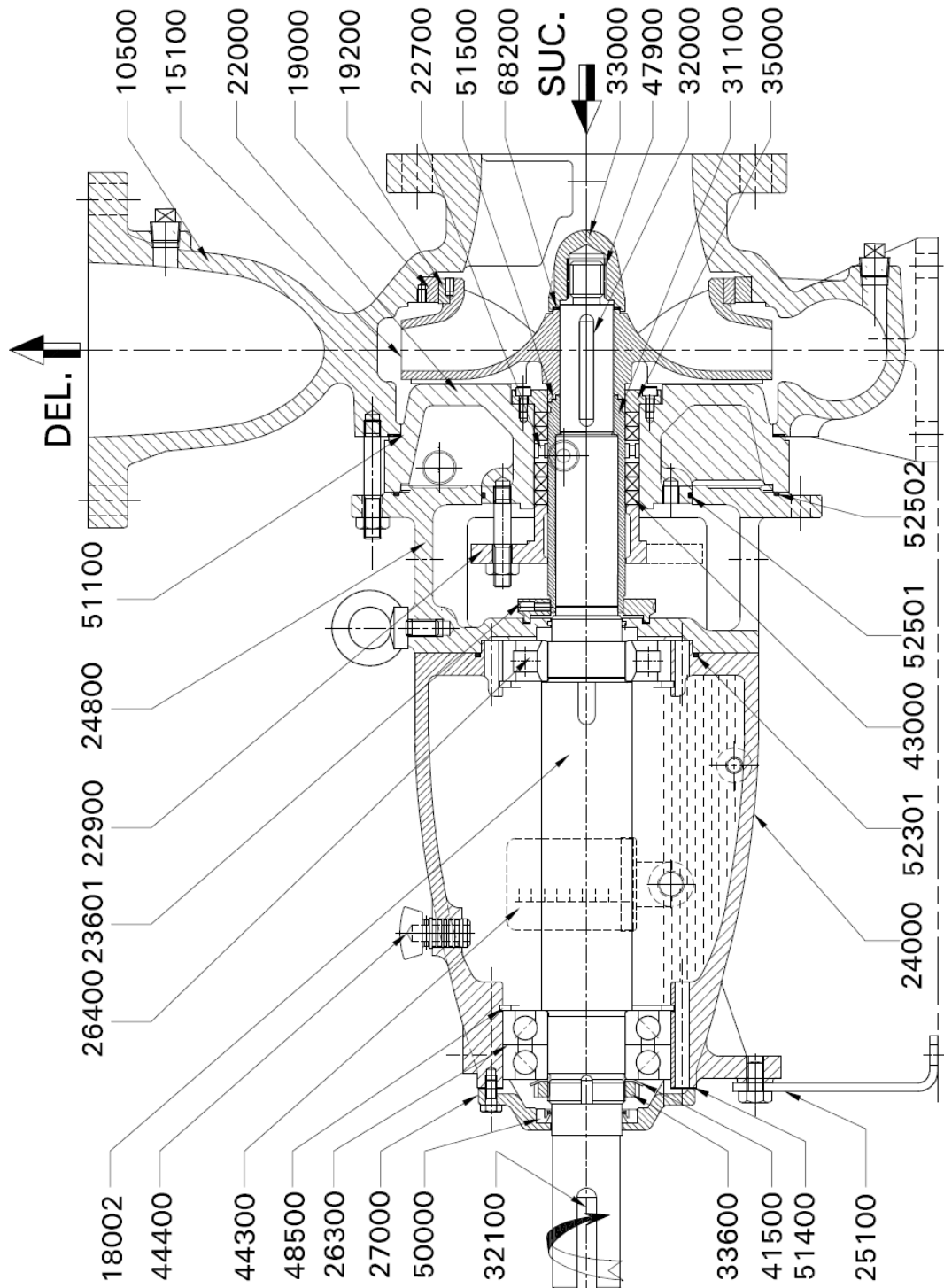

5. KPD200/26,200/33,200/36,250/33A & B



Enriching Lives

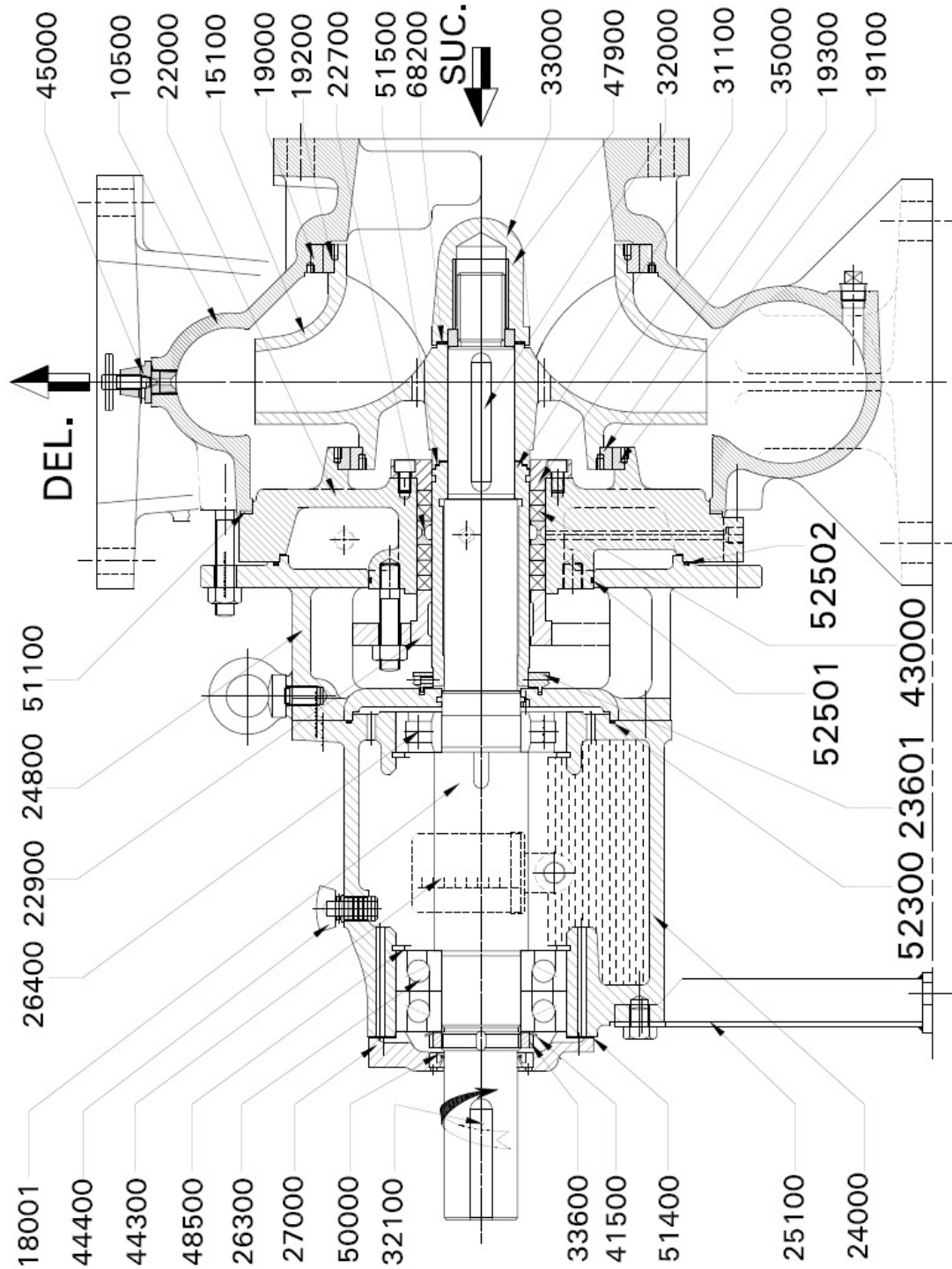

6. KPD250/50, 250/40



Enriching Lives

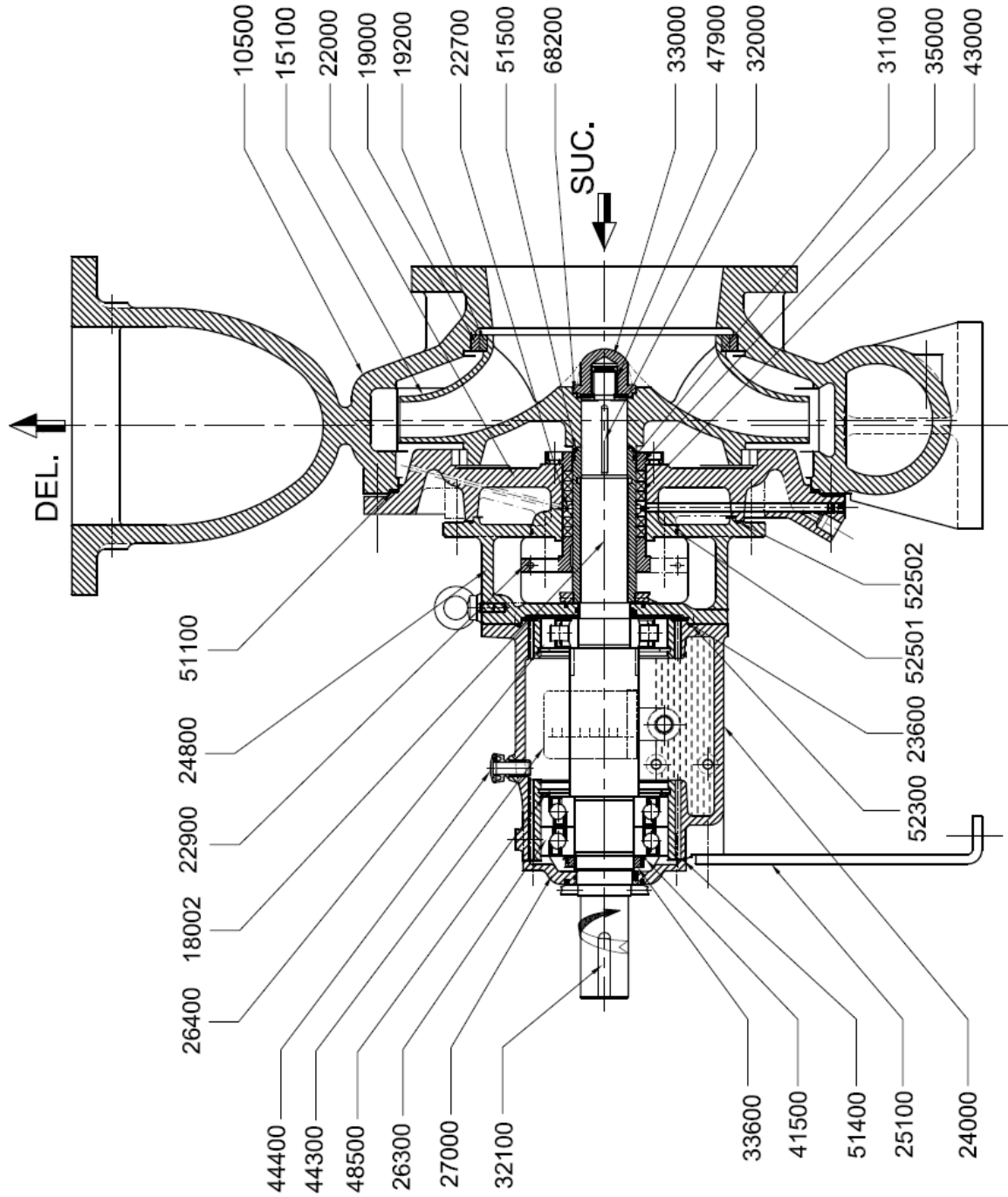

7. KPD150/56, KPD 350/40

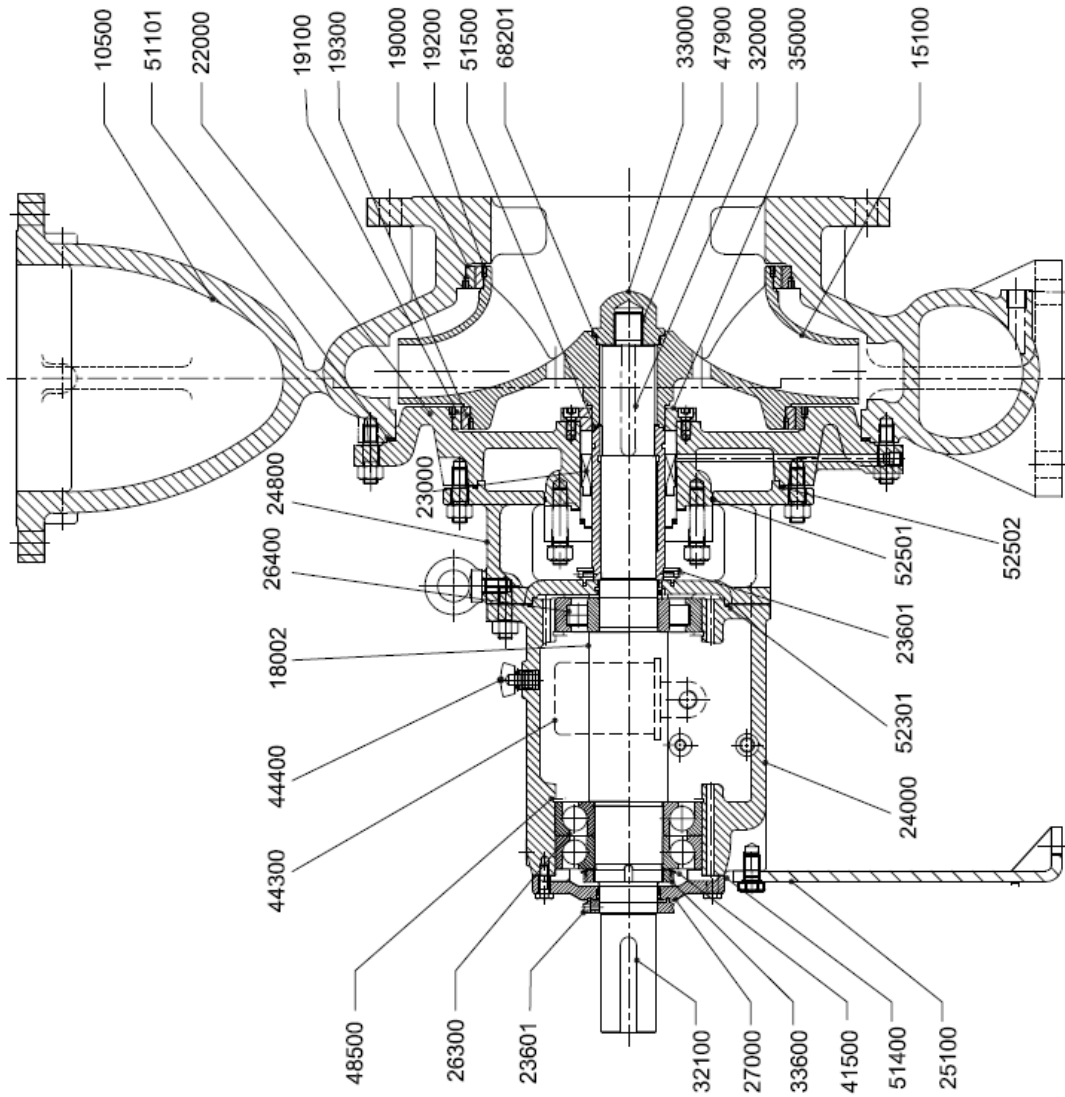

8. KPD CLM pump

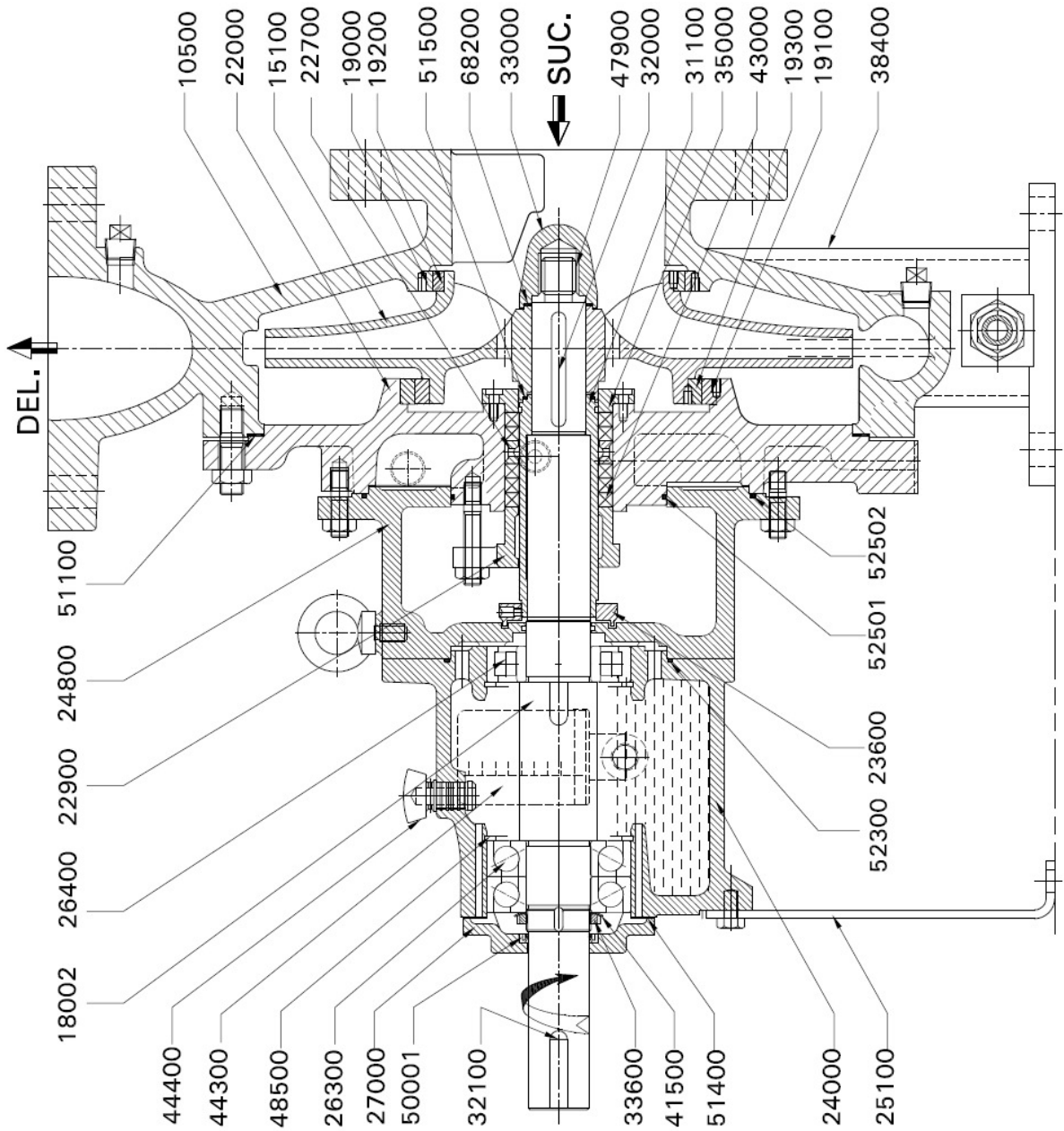

9. KPD CLM PUMP End view



Enriching Lives

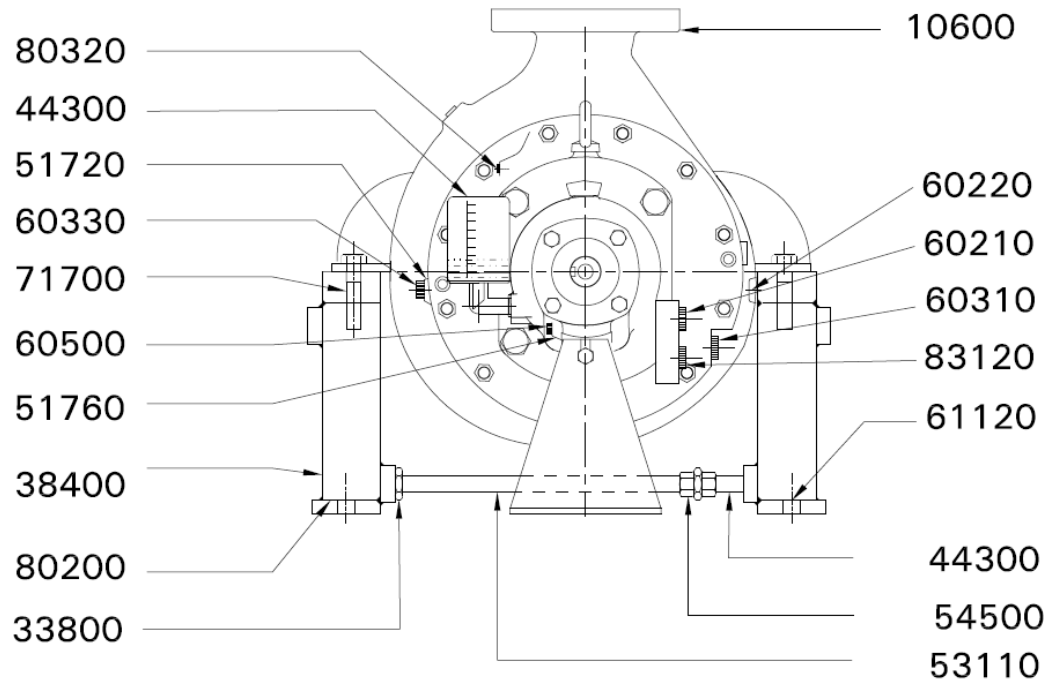

10. KPD Standard pump End view

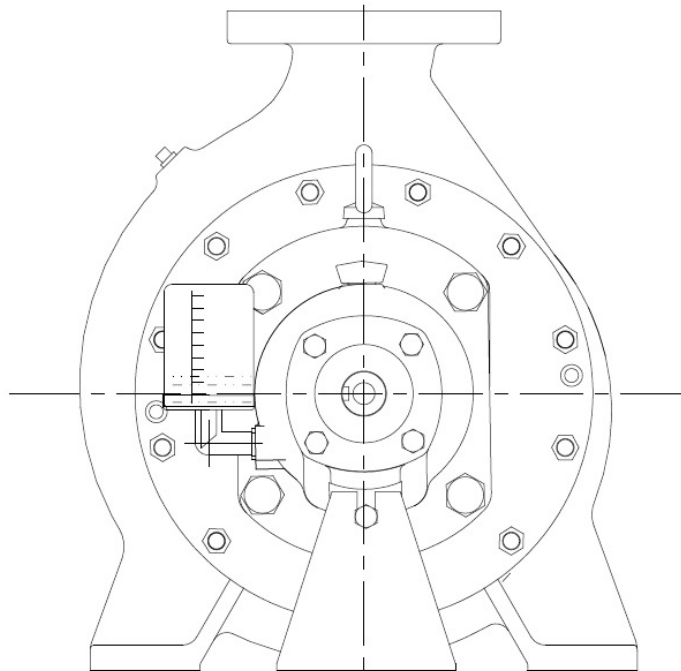

11. General KPDQF pump



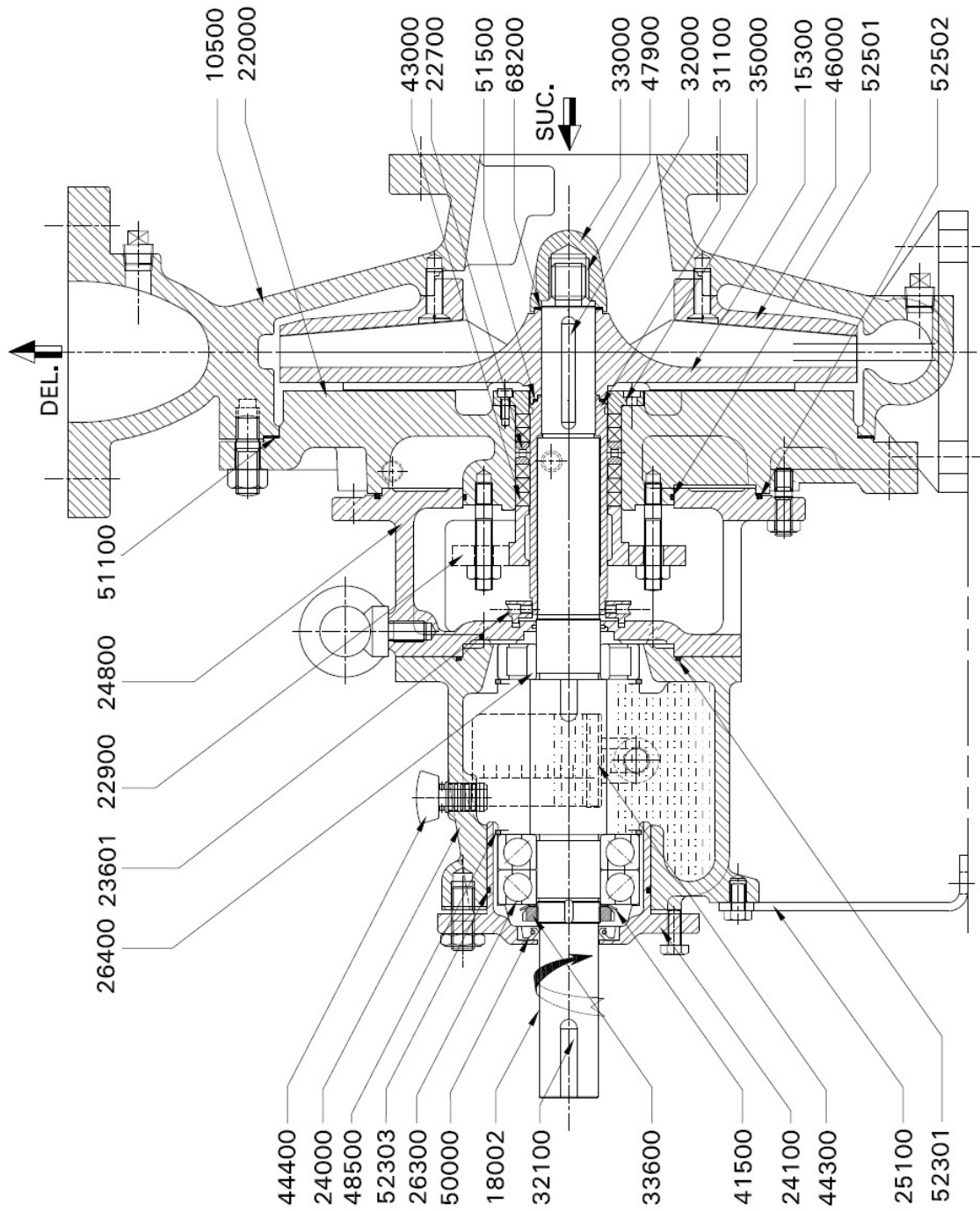

12. KPDJ pump



Enriching Lives

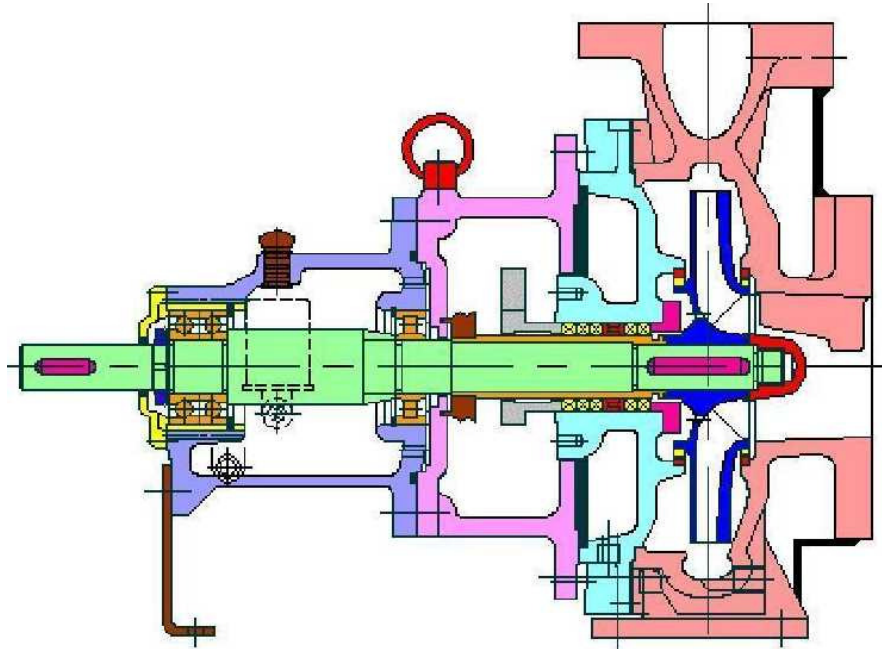

13. KPDJ pump General cross section:

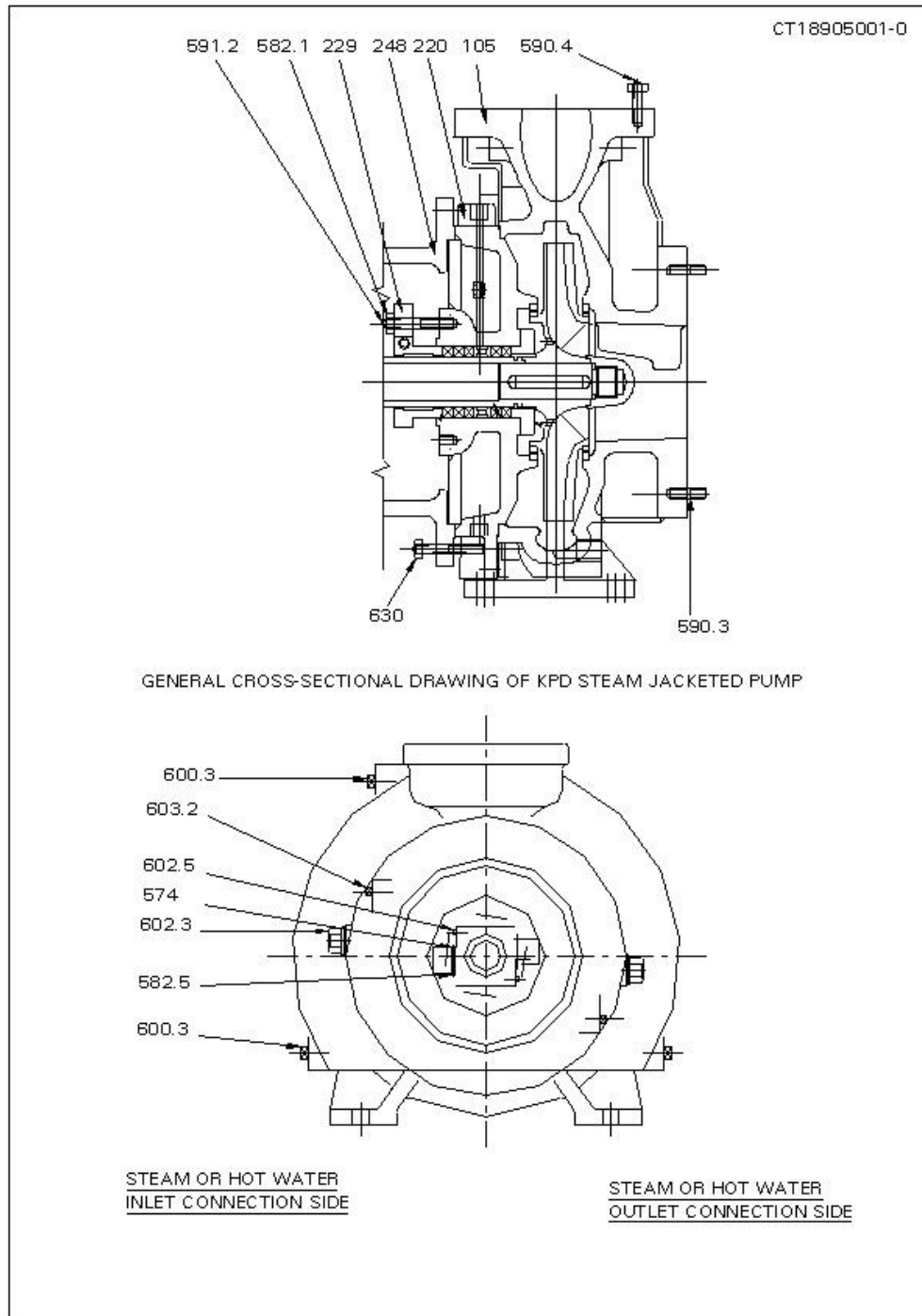

14. KPD pump with gland packing.



Enriching Lives

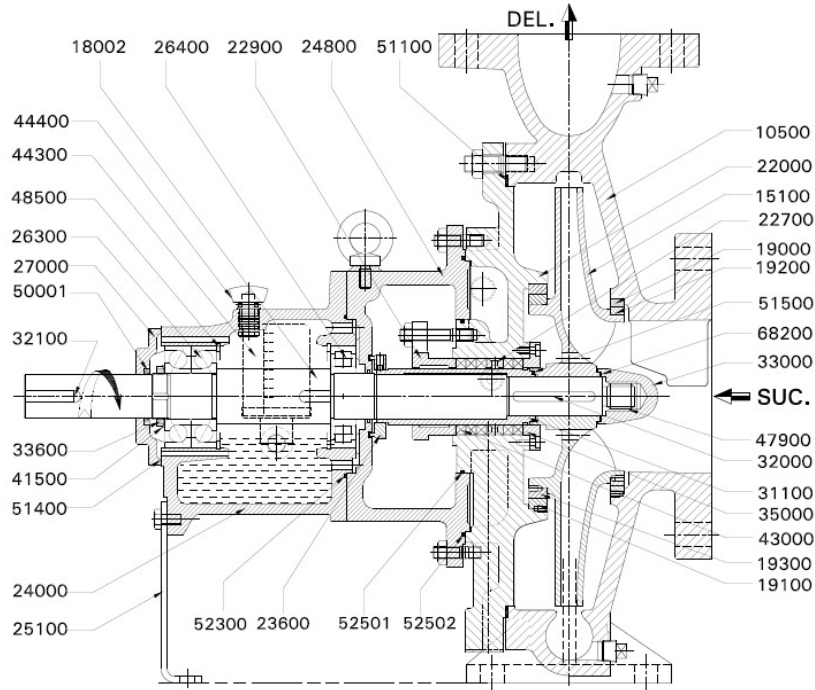

15. KPD pump with mechanical seal arrangement:

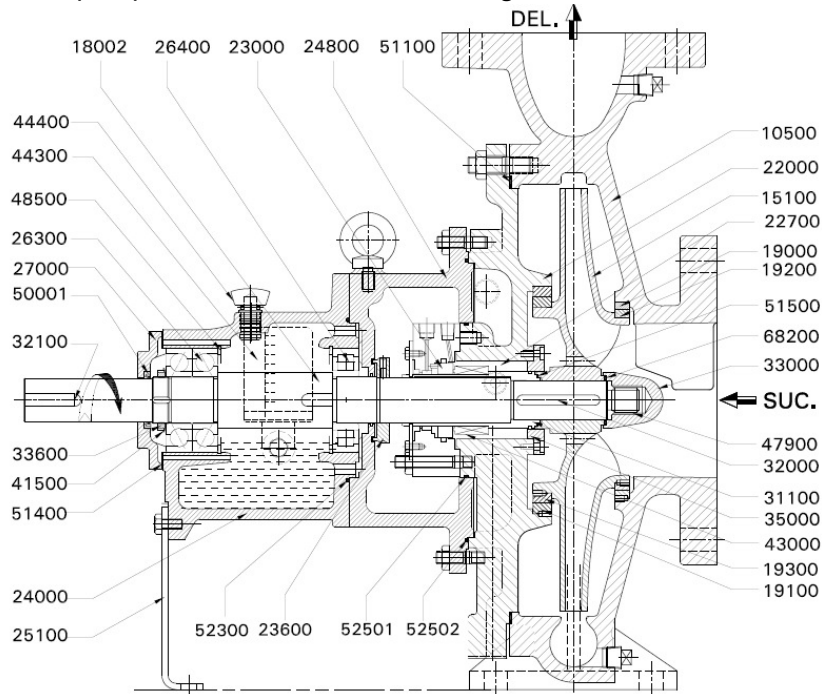

16. Bearing cooling arrangement



Enriching Lives

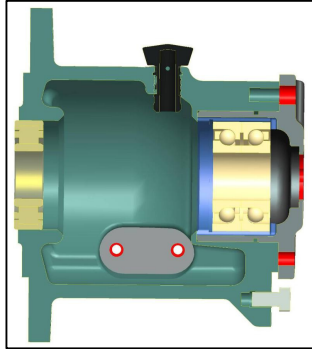
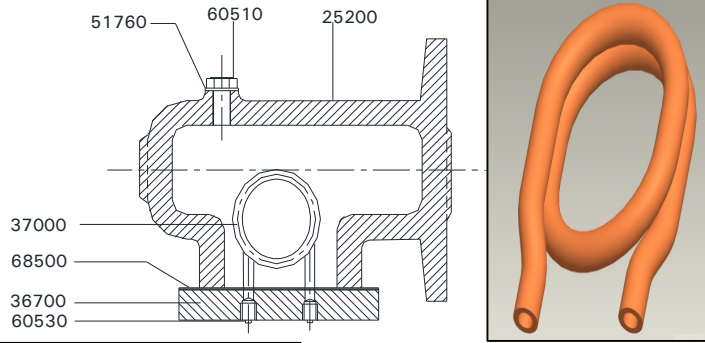

17. Mechanical seal:

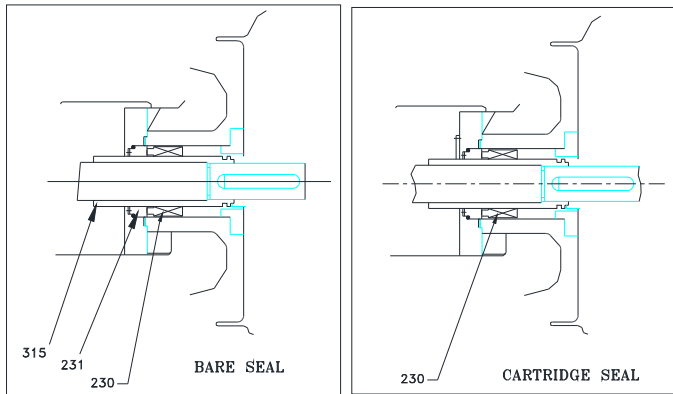

18. Casing drain piping:

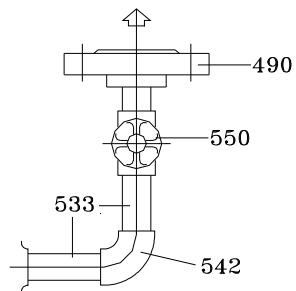

### 19.KPD pump cut section view

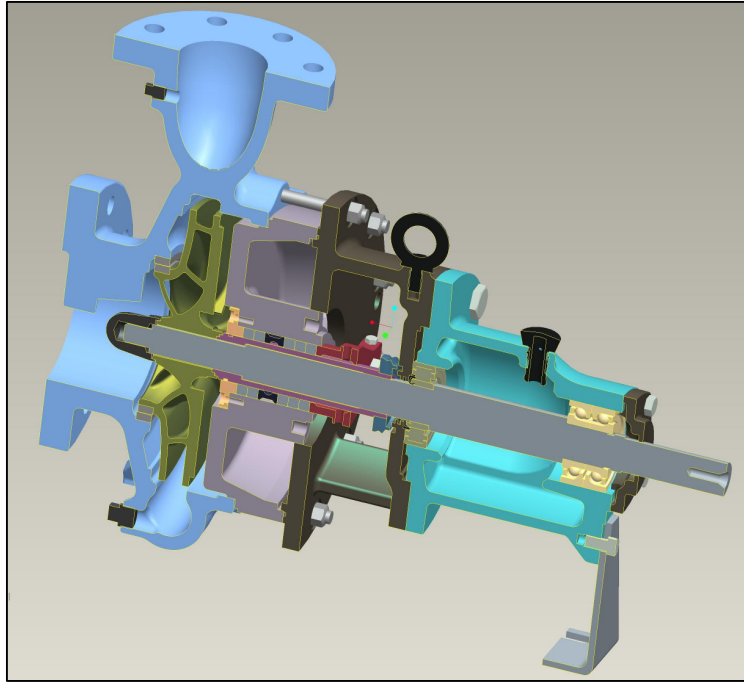

### 20.Cut section view of KPDQF pump:



Enriching Lives

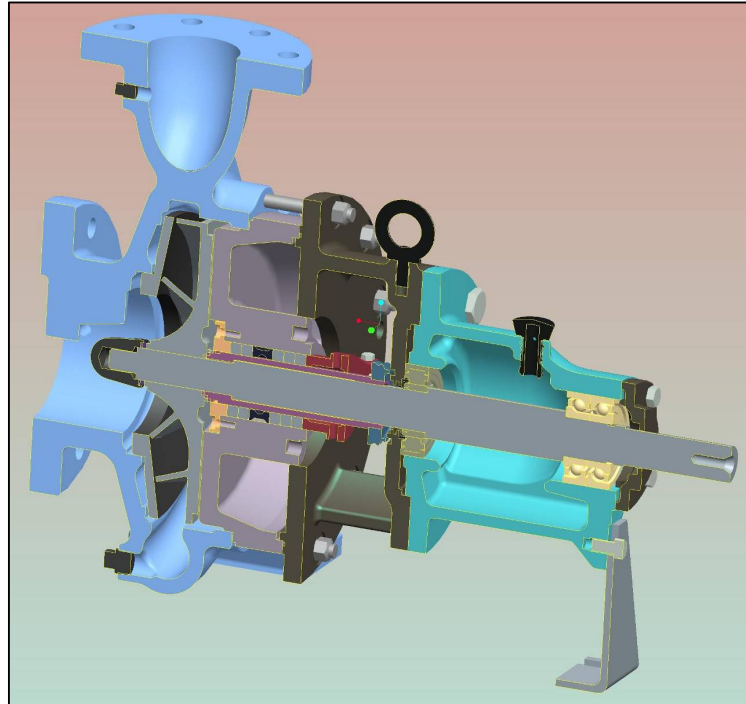

**21. Exploded view of KPD pump:**



Enriching Lives

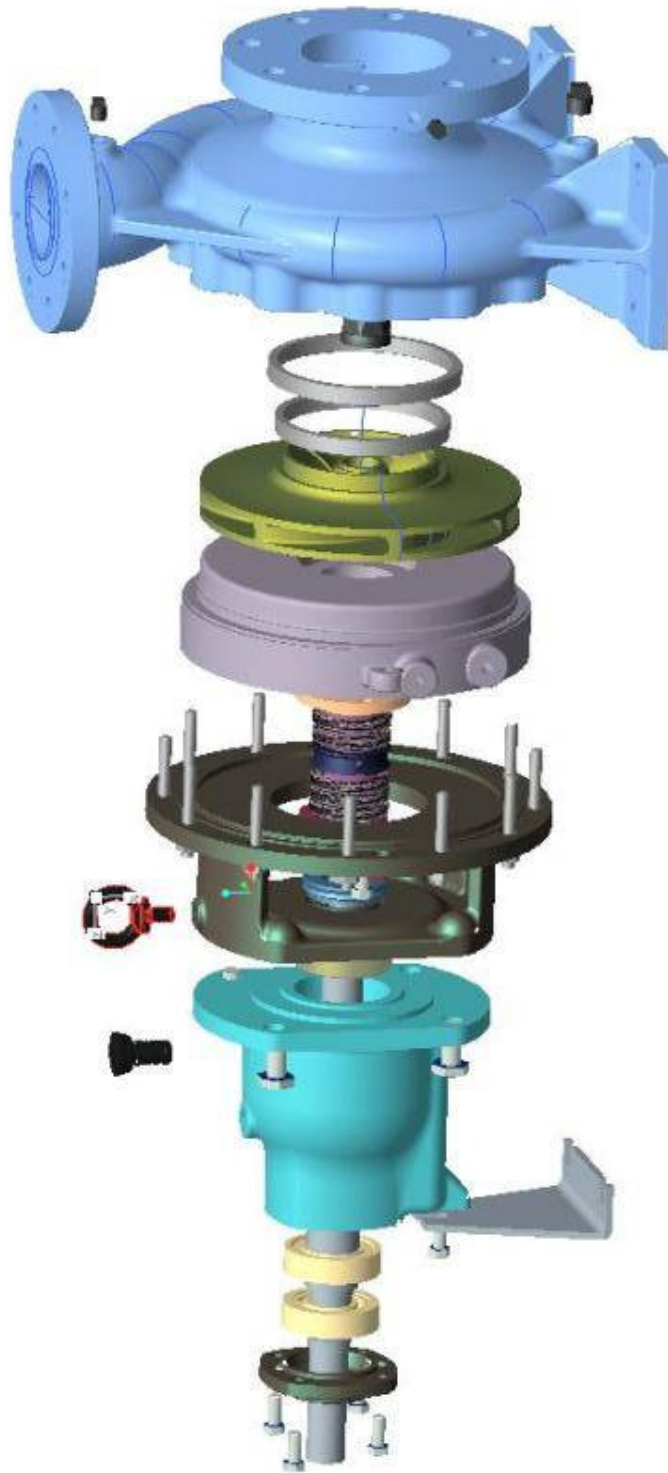

Enriching Lives



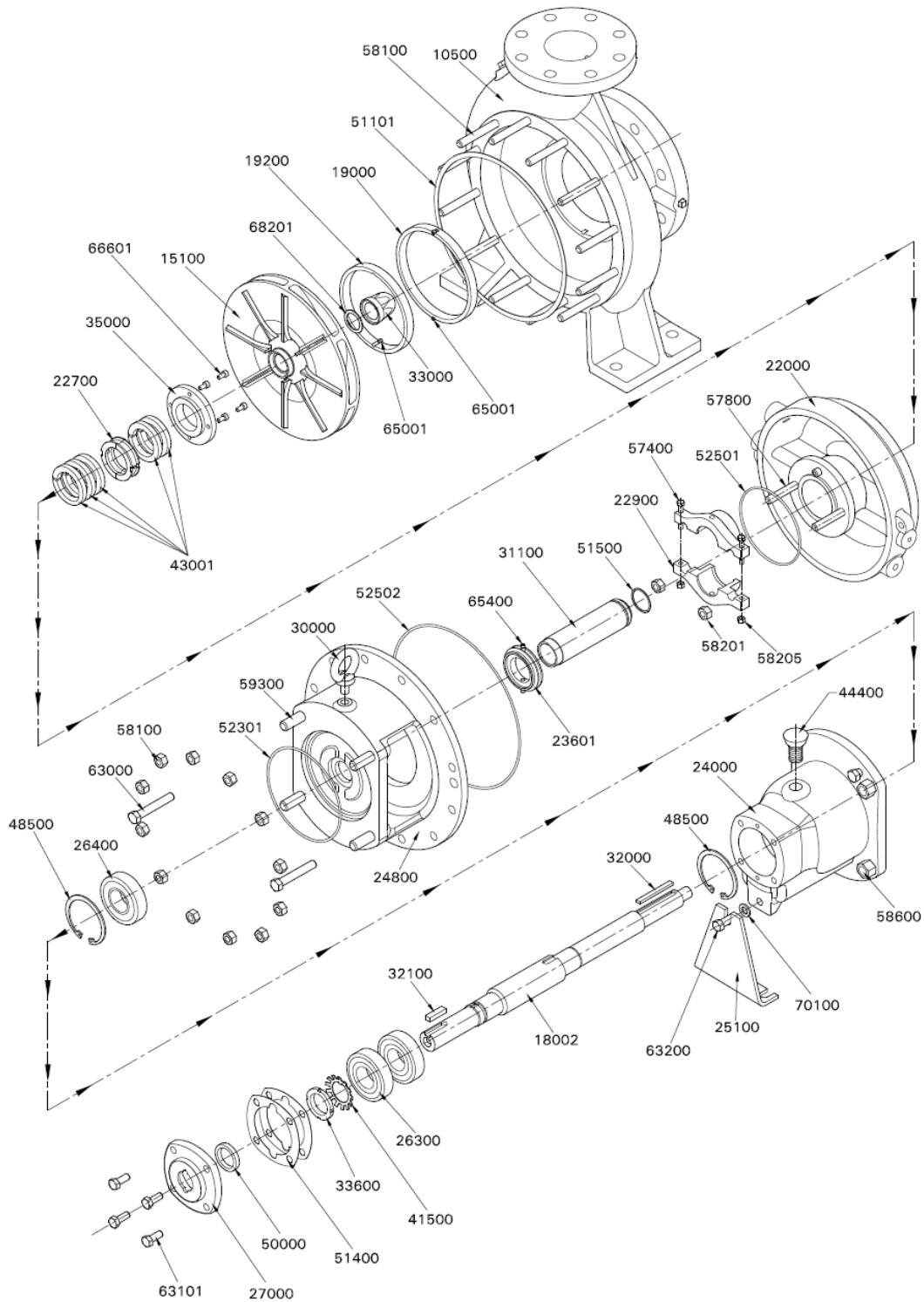



Enriching Lives

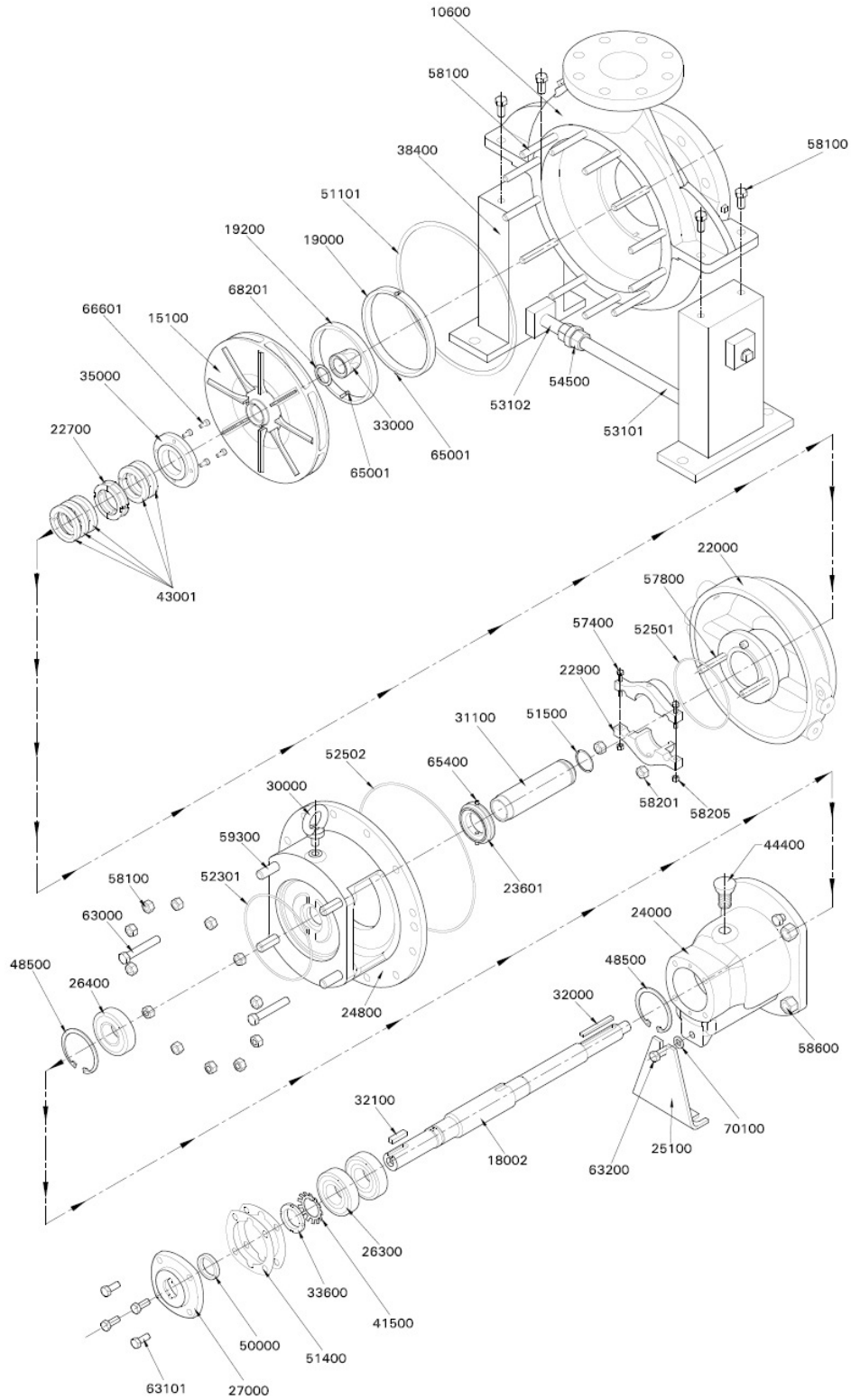

### GENERAL OUTLINE DIMENSIONS OF KPD/KPDQF PUMPS (FM)

#### 1. Figure A

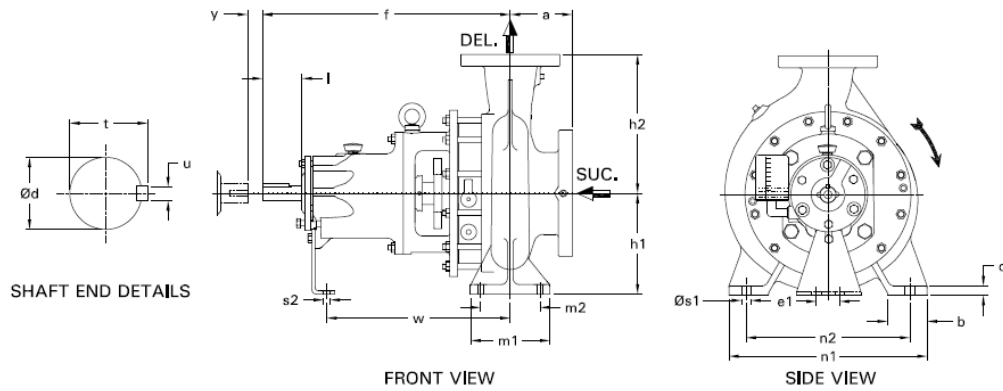

2. Figure B

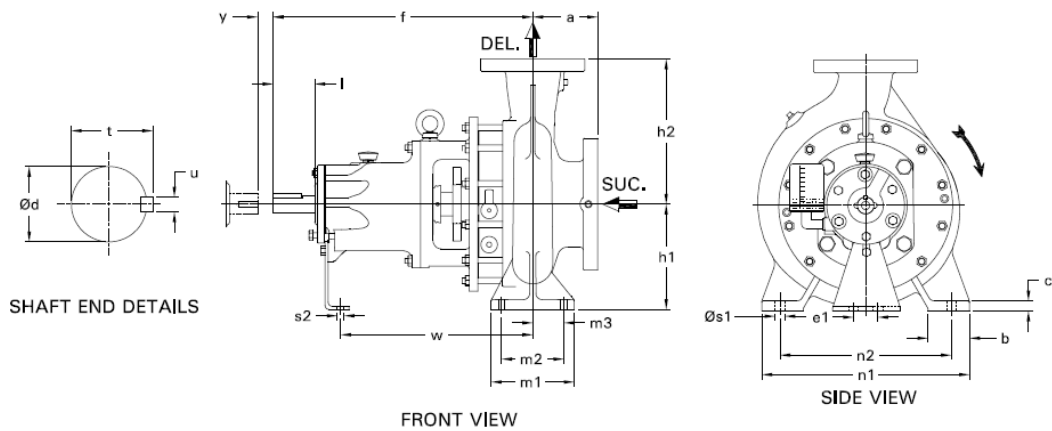

3. Figure C

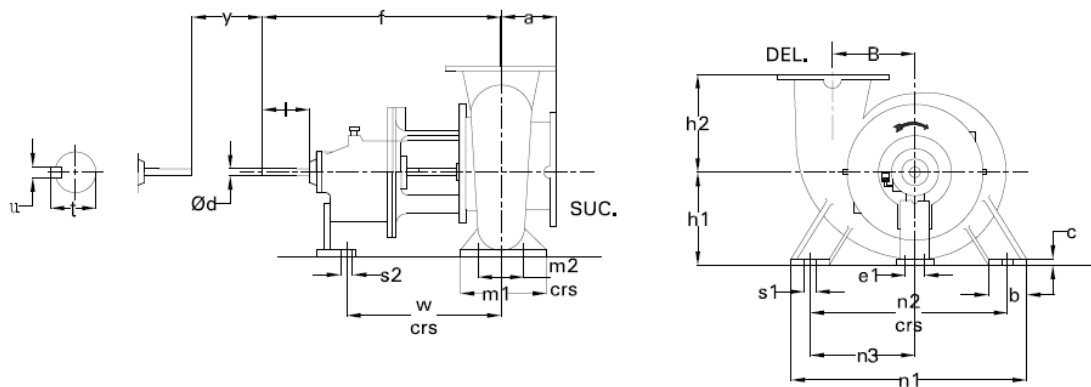

4. Figure D

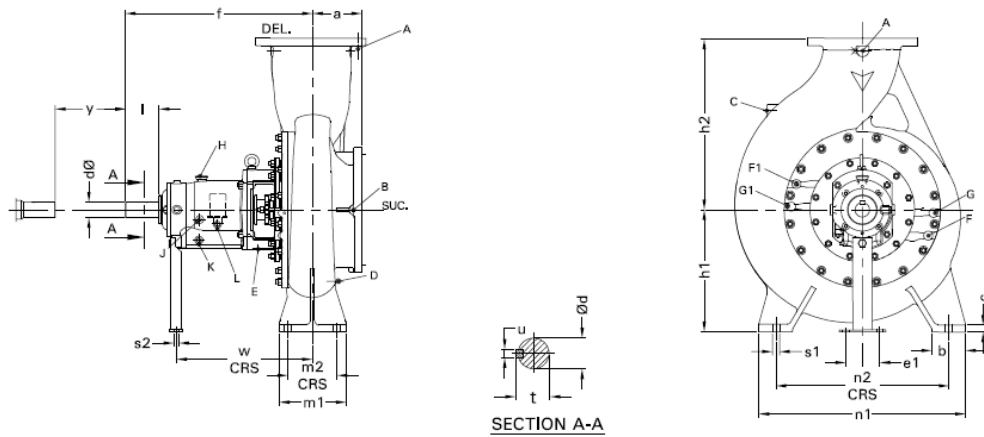

### GENERAL OUTLINE DIMENSIONS OF KPD PUMPS (CLM)

1. Figure E .

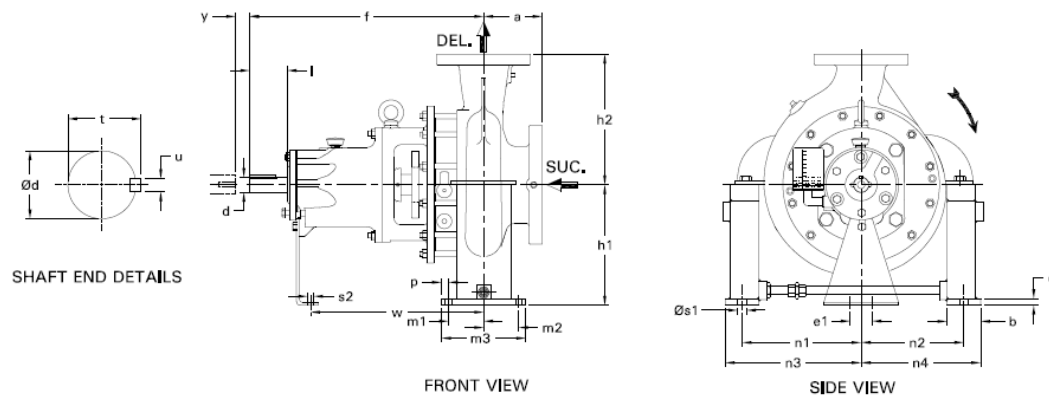
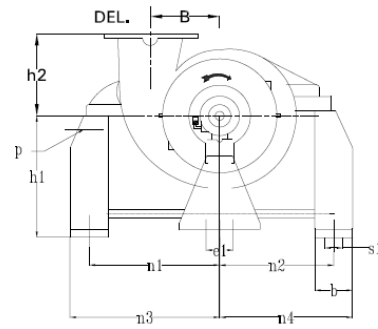
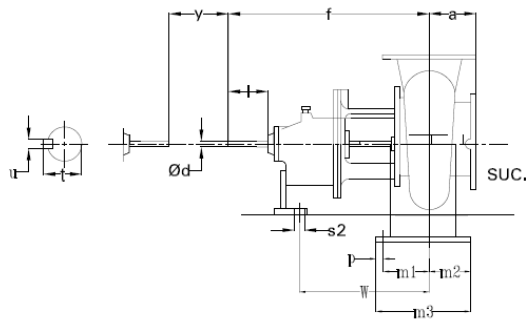

Figure F.



Enriching Lives





Enriching Lives

GENERAL OUTLINE DIMENSIONS OF KPD/KPDP PUMPS. (KPD UNIT 4, 5, 7)

| PRODCD1 | PUMP       | FIG | SUC | DEL | UNIT | a   | f   | h1  | h2  | B  | b  | c  | m1  | m2  | m3 | n1  | n2  | n3 | w   | s1 | s2 | e1  | d  | l  | t  | u  | y   |
|---------|------------|-----|-----|-----|------|-----|-----|-----|-----|----|----|----|-----|-----|----|-----|-----|----|-----|----|----|-----|----|----|----|----|-----|
| 13F41   | KPD20/13QF | A   | 25  | 20  | 4    | 80  | 385 | 100 | 140 | NA | 50 | 10 | 80  | 50  | NA | 190 | 140 | NA | 285 | 14 | 14 | 110 | 18 | 40 | 21 | 6  | 100 |
| 13F42   | KPD20/16QF | A   | 25  | 20  | 4    | 80  | 385 | 132 | 150 | NA | 50 | 10 | 100 | 70  | NA | 210 | 180 | NA | 285 | 14 | 14 | 110 | 18 | 40 | 21 | 6  | 100 |
| 13F43   | KPD20/20QF | A   | 25  | 20  | 4    | 80  | 385 | 160 | 170 | NA | 50 | 10 | 100 | 70  | NA | 240 | 190 | NA | 285 | 14 | 14 | 110 | 18 | 40 | 21 | 6  | 100 |
| 13F37   | KPD25/16QF | A   | 40  | 25  | 5    | 100 | 385 | 132 | 165 | NA | 50 | 14 | 100 | 70  | NA | 210 | 160 | NA | 285 | 14 | 15 | 110 | 24 | 8  | 27 | 50 | 100 |
| 13701   | KPD32/13   | A   | 50  | 32  | 5    | 80  | 385 | 112 | 140 | NA | 50 | 14 | 100 | 70  | NA | 190 | 140 | NA | 285 | 14 | 15 | 110 | 24 | 50 | 27 | 8  | 100 |
| 13702   | KPD32/16   | A   | 50  | 32  | 5    | 80  | 385 | 132 | 160 | NA | 50 | 14 | 100 | 70  | NA | 240 | 190 | NA | 285 | 14 | 15 | 110 | 24 | 50 | 27 | 8  | 100 |
| 13703   | KPD32/20   | A   | 50  | 32  | 5    | 80  | 385 | 160 | 180 | NA | 50 | 14 | 100 | 70  | NA | 240 | 190 | NA | 285 | 14 | 15 | 110 | 24 | 50 | 27 | 8  | 100 |
| 14402   | KPD32/16A  | A   | 50  | 32  | 5    | 80  | 385 | 132 | 160 | NA | 50 | 14 | 100 | 70  | NA | 240 | 190 | NA | 285 | 14 | 15 | 110 | 24 | 50 | 27 | 8  | 100 |
| 14403   | KPD32/20A  | A   | 50  | 32  | 5    | 80  | 385 | 160 | 180 | NA | 50 | 14 | 100 | 70  | NA | 240 | 190 | NA | 285 | 14 | 15 | 110 | 24 | 50 | 27 | 8  | 100 |
| 14407   | KPD40/20A  | A   | 65  | 40  | 5    | 100 | 385 | 160 | 180 | NA | 50 | 14 | 100 | 70  | NA | 285 | 212 | NA | 285 | 14 | 15 | 110 | 24 | 50 | 27 | 8  | 100 |
| 14411   | KPD50/16A  | A   | 80  | 50  | 5    | 100 | 385 | 160 | 180 | NA | 50 | 14 | 100 | 70  | NA | 285 | 212 | NA | 285 | 14 | 15 | 110 | 24 | 50 | 27 | 8  | 100 |
| 13705   | KPD40/13   | A   | 65  | 40  | 5    | 80  | 385 | 112 | 140 | NA | 50 | 14 | 100 | 70  | NA | 210 | 160 | NA | 285 | 14 | 15 | 110 | 24 | 50 | 27 | 8  | 100 |
| 13706   | KPD40/16   | A   | 65  | 40  | 5    | 80  | 385 | 132 | 160 | NA | 50 | 14 | 100 | 70  | NA | 240 | 190 | NA | 285 | 14 | 15 | 110 | 24 | 50 | 27 | 8  | 100 |
| 13707   | KPD40/20   | A   | 65  | 40  | 5    | 100 | 385 | 160 | 180 | NA | 50 | 14 | 100 | 70  | NA | 285 | 212 | NA | 285 | 14 | 15 | 110 | 24 | 50 | 27 | 8  | 100 |
| 13710   | KPD50/13   | A   | 80  | 50  | 5    | 100 | 385 | 132 | 160 | NA | 50 | 14 | 100 | 70  | NA | 240 | 190 | NA | 285 | 14 | 15 | 110 | 24 | 50 | 27 | 8  | 100 |
| 13711   | KPD50/16   | A   | 80  | 50  | 5    | 100 | 385 | 160 | 180 | NA | 50 | 14 | 100 | 70  | NA | 285 | 212 | NA | 285 | 14 | 15 | 110 | 24 | 50 | 27 | 8  | 100 |
| 13712   | KPD50/20   | A   | 80  | 50  | 5    | 100 | 385 | 180 | 200 | NA | 50 | 14 | 100 | 70  | NA | 285 | 212 | NA | 285 | 14 | 15 | 110 | 24 | 50 | 27 | 8  | 100 |
| 13715   | KPD55/13   | A   | 100 | 65  | 5    | 100 | 385 | 160 | 180 | NA | 65 | 14 | 125 | 95  | NA | 280 | 212 | NA | 285 | 14 | 15 | 110 | 24 | 50 | 27 | 8  | 100 |
| 13745   | KPD32/26   | A   | 50  | 32  | 7    | 100 | 500 | 180 | 225 | NA | 65 | 14 | 125 | 95  | NA | 320 | 250 | NA | 370 | 14 | 15 | 110 | 32 | 80 | 35 | 10 | 140 |
| 13746   | KPD40/26   | A   | 65  | 40  | 7    | 100 | 500 | 180 | 225 | NA | 65 | 14 | 125 | 95  | NA | 320 | 250 | NA | 370 | 14 | 15 | 110 | 32 | 80 | 35 | 10 | 140 |
| 13747   | KPD40/32   | A   | 65  | 40  | 7    | 125 | 500 | 200 | 250 | NA | 65 | 14 | 125 | 95  | NA | 345 | 280 | NA | 370 | 14 | 15 | 110 | 32 | 80 | 35 | 10 | 140 |
| 13748   | KPD50/26   | A   | 80  | 50  | 7    | 125 | 500 | 180 | 225 | NA | 65 | 14 | 125 | 95  | NA | 320 | 250 | NA | 370 | 14 | 15 | 110 | 32 | 80 | 35 | 10 | 140 |
| 13749   | KPD50/32   | A   | 80  | 50  | 7    | 125 | 500 | 225 | 280 | NA | 65 | 14 | 125 | 95  | NA | 345 | 280 | NA | 370 | 14 | 15 | 110 | 32 | 80 | 35 | 10 | 140 |
| 13750   | KPD55/16   | A   | 100 | 65  | 7    | 100 | 500 | 160 | 200 | NA | 65 | 14 | 125 | 95  | NA | 280 | 212 | NA | 370 | 14 | 15 | 110 | 32 | 80 | 35 | 10 | 140 |
| 13751   | KPD55/20   | A   | 100 | 65  | 7    | 100 | 500 | 180 | 225 | NA | 65 | 14 | 125 | 95  | NA | 320 | 250 | NA | 370 | 14 | 15 | 110 | 32 | 80 | 35 | 10 | 140 |
| 13752   | KPD55/26   | A   | 100 | 65  | 7    | 125 | 500 | 200 | 250 | NA | 80 | 16 | 160 | 120 | NA | 360 | 280 | NA | 370 | 18 | 15 | 110 | 32 | 80 | 35 | 10 | 140 |
| 13753   | KPD80/16   | A   | 125 | 80  | 7    | 125 | 500 | 180 | 225 | NA | 65 | 14 | 125 | 95  | NA | 320 | 250 | NA | 370 | 14 | 15 | 110 | 32 | 80 | 35 | 10 | 140 |
| 13754   | KPD80/20   | A   | 125 | 80  | 7    | 125 | 500 | 180 | 250 | NA | 65 | 14 | 125 | 95  | NA | 345 | 280 | NA | 370 | 14 | 15 | 110 | 32 | 80 | 35 | 10 | 140 |
| 13755   | KPD80/26   | A   | 125 | 80  | 7    | 125 | 500 | 225 | 280 | NA | 80 | 16 | 160 | 120 | NA | 400 | 315 | NA | 370 | 18 | 15 | 110 | 32 | 80 | 35 | 10 | 140 |
| 13770   | KPD100/16  | A   | 125 | 100 | 7    | 150 | 500 | 225 | 280 | NA | 65 | 14 | 125 | 95  | NA | 320 | 250 | NA | 370 | 14 | 15 | 110 | 32 | 80 | 35 | 10 | 140 |
| 13756   | KPD100/20  | A   | 125 | 100 | 7    | 125 | 500 | 200 | 280 | NA | 80 | 16 | 160 | 120 | NA | 360 | 280 | NA | 370 | 18 | 15 | 110 | 32 | 80 | 35 | 10 | 140 |
| 13757   | KPD55/26N  | A   | 100 | 65  | 7    | 125 | 500 | 200 | 250 | NA | 80 | 16 | 160 | 120 | NA | 360 | 280 | NA | 370 | 18 | 15 | 110 | 32 | 80 | 35 | 10 | 140 |
| 13783   | KPD26/26A  | A   | 50  | 25  | 7    | 100 | 500 | 180 | 225 | NA | 65 | 14 | 125 | 95  | NA | 320 | 250 | NA | 370 | 14 | 15 | 110 | 32 | 80 | 35 | 10 | 140 |



GENERAL OUTLINE DIMENSIONS OF KFD/KDGF PUMPS (KFD UNIT 9,11,13,15,19)

| PRODCD1 | PUMP                 | FIG | SUC | DEL | UNIT | a   | f   | h1  | h2  | B   | b   | c  | m1  | m2  | m3 | n1   | n2   | n3  | w     | s1 | s2 | e1  | d  | i     | t    | u  | y   |
|---------|----------------------|-----|-----|-----|------|-----|-----|-----|-----|-----|-----|----|-----|-----|----|------|------|-----|-------|----|----|-----|----|-------|------|----|-----|
| 13719   | KFD150/32<br>145GRPM | A   | 100 | 65  | 9    | 125 | 530 | 225 | 280 | NA  | 80  | 16 | 160 | 120 | NA | 400  | 315  | NA  | 370   | 18 | 15 | 110 | 42 | 110   | 45   | 12 | 140 |
| 13723   | KFD200/32            | A   | 125 | 80  | 9    | 125 | 530 | 250 | 315 | NA  | 80  | 16 | 160 | 120 | NA | 400  | 315  | NA  | 370   | 18 | 15 | 110 | 42 | 110   | 45   | 12 | 140 |
| 13724   | KFD250/40            | A   | 125 | 80  | 9    | 125 | 530 | 280 | 355 | NA  | 80  | 16 | 160 | 120 | NA | 435  | 355  | NA  | 370   | 18 | 15 | 110 | 42 | 110   | 45   | 12 | 140 |
| 13726   | KFD100/26            | A   | 125 | 100 | 9    | 140 | 530 | 225 | 280 | NA  | 80  | 16 | 160 | 120 | NA | 400  | 315  | NA  | 370   | 18 | 15 | 110 | 42 | 110   | 45   | 12 | 140 |
| 13727   | KFD100/32            | A   | 125 | 100 | 9    | 140 | 530 | 250 | 315 | NA  | 80  | 16 | 160 | 120 | NA | 400  | 315  | NA  | 370   | 18 | 15 | 110 | 42 | 110   | 45   | 12 | 140 |
| 13778   | KFD100/32N           | A   | 125 | 100 | 9    | 140 | 530 | 250 | 315 | NA  | 80  | 16 | 160 | 120 | NA | 400  | 315  | NA  | 370   | 18 | 15 | 110 | 42 | 110   | 45   | 12 | 140 |
| 13728   | KFD100/40            | A   | 125 | 100 | 9    | 140 | 530 | 280 | 355 | NA  | 100 | 16 | 200 | 150 | NA | 500  | 400  | NA  | 370   | 23 | 15 | 110 | 42 | 110   | 45   | 12 | 140 |
| 13729   | KFD150/26<br>145GRPM | A   | 150 | 125 | 9    | 140 | 530 | 250 | 355 | NA  | 80  | 16 | 160 | 120 | NA | 400  | 315  | NA  | 370   | 18 | 15 | 110 | 42 | 110   | 45   | 12 | 140 |
| 13730   | KFD125/32            | A   | 150 | 125 | 9    | 140 | 530 | 280 | 355 | NA  | 100 | 18 | 200 | 150 | NA | 500  | 400  | NA  | 370   | 23 | 15 | 110 | 42 | 110   | 45   | 12 | 140 |
| 13731   | KFD125/40            | A   | 150 | 125 | 9    | 140 | 530 | 315 | 400 | NA  | 100 | 18 | 200 | 150 | NA | 500  | 400  | NA  | 370   | 23 | 15 | 110 | 42 | 110   | 45   | 12 | 140 |
| 13732   | KFD150/32            | A   | 200 | 150 | 9    | 160 | 530 | 315 | 400 | NA  | 100 | 22 | 200 | 150 | NA | 500  | 450  | NA  | 370   | 23 | 15 | 110 | 42 | 110   | 45   | 12 | 140 |
| 13733   | KFD150/40            | A   | 200 | 150 | 9    | 160 | 530 | 315 | 450 | NA  | 100 | 18 | 200 | 150 | NA | 550  | 450  | NA  | 370   | 23 | 15 | 110 | 42 | 110   | 45   | 12 | 140 |
| 13740   | KFD150/32<br>290GRPM | A   | 100 | 65  | 9    | 125 | 530 | 225 | 280 | NA  | 80  | 16 | 160 | 120 | NA | 400  | 315  | NA  | 370   | 18 | 15 | 110 | 42 | 110   | 45   | 12 | 140 |
| 13744   | KFD150/32N           | A   | 200 | 150 | 9    | 160 | 530 | 315 | 400 | NA  | 100 | 22 | 200 | 150 | NA | 500  | 400  | NA  | 370   | 23 | 15 | 110 | 42 | 110   | 45   | 12 | 140 |
| 13758   | KFD200/40N           | A   | 125 | 80  | 9    | 125 | 530 | 280 | 355 | NA  | 80  | 16 | 160 | 120 | NA | 435  | 355  | NA  | 370   | 18 | 15 | 110 | 42 | 110   | 45   | 12 | 140 |
| 13759   | KFD125/40N           | A   | 150 | 125 | 9    | 140 | 530 | 315 | 400 | NA  | 100 | 18 | 200 | 150 | NA | 500  | 400  | NA  | 370   | 23 | 15 | 110 | 42 | 110   | 45   | 12 | 140 |
| 13762   | KFD250/43            | B   | 100 | 65  | 9    | 160 | 530 | 280 | 365 | NA  | 80  | 16 | 160 | 120 | 60 | 435  | 355  | NA  | 370   | 18 | 15 | 110 | 42 | 110   | 45   | 12 | 140 |
| 13771   | KFD125/20            | A   | 150 | 125 | 9    | 140 | 530 | 250 | 315 | NA  | 80  | 16 | 160 | 120 | NA | 400  | 315  | NA  | 370   | 18 | 15 | 110 | 42 | 110   | 45   | 12 | 140 |
| 13782   | KFD150/26            | A   | 200 | 150 | 9    | 160 | 530 | 280 | 375 | NA  | 100 | 20 | 200 | 150 | NA | 500  | 400  | NA  | 370   | 23 | 16 | 110 | 42 | 110   | 45   | 12 | 140 |
| 13761   | KFD125/45            | B   | 150 | 125 | 11   | 160 | 670 | 350 | 450 | NA  | 100 | 20 | 180 | 120 | 70 | 550  | 450  | NA  | 500   | 23 | 19 | 140 | 48 | 110   | 51.4 | 14 | 180 |
| 13764   | KFD150/43            | B   | 200 | 150 | 11   | 160 | 685 | 350 | 475 | NA  | 100 | 20 | 180 | 120 | 70 | 550  | 450  | NA  | 514   | 23 | 19 | 140 | 48 | 110   | 51.4 | 14 | 180 |
| 13767   | KFD200/32<br>290GRPM | A   | 150 | 125 | 11   | 140 | 670 | 250 | 355 | NA  | 80  | 16 | 160 | 120 | NA | 400  | 315  | NA  | 500   | 18 | 19 | 140 | 48 | 110   | 51.5 | 14 | 180 |
| 13768   | KFD200/40DV          | A   | 125 | 80  | 11   | 125 | 670 | 280 | 355 | NA  | 80  | 16 | 160 | 120 | NA | 435  | 355  | NA  | 500   | 18 | 19 | 140 | 48 | 110   | 51.5 | 14 | 180 |
| 13767   | KFD100/40D           | A   | 150 | 100 | 11   | 140 | 670 | 280 | 355 | NA  | 100 | 18 | 200 | 150 | NA | 500  | 400  | NA  | 500   | 23 | 19 | 140 | 48 | 110   | 51.5 | 14 | 180 |
| 13780   | KFD200/33            | C   | 200 | 200 | 11C  | 200 | 720 | 370 | 315 | NA  | 100 | 25 | 335 | 265 | NA | 530  | 560  | NA  | 550   | 27 | 19 | 140 | 48 | 110   | 51.5 | 14 | 180 |
| 13781   | KFD200/36            | C   | 200 | 200 | 11   | 200 | 718 | 350 | 300 | 250 | 110 | 25 | 280 | 200 | NA | 640  | 530  | 295 | 548   | 27 | 19 | 140 | 48 | 110   | 51.5 | 14 | 180 |
| 13781   | KFD125/32            | A   | 150 | 125 | 13   | 140 | 643 | 280 | 355 | NA  | 100 | 18 | 200 | 150 | NA | 500  | 400  | NA  | 457   | 23 | 15 | 140 | 60 | 110   | 64.4 | 18 | 180 |
| 13789   | KFD200/38M           | A   | 280 | 200 | 13   | 200 | 670 | 400 | 500 | NA  | 120 | 30 | 240 | 180 | NA | 550  | 430  | NA  | 483.5 | 27 | 19 | 140 | 60 | 110   | 64.4 | 18 | 180 |
| 13795   | KFD200/46            | A   | 250 | 200 | 13   | 200 | 670 | 425 | 550 | NA  | 120 | 30 | 240 | 180 | NA | 640  | 540  | NA  | 483   | 27 | 19 | 140 | 60 | 110   | 64.4 | 18 | 180 |
| 13760   | KFD150/32            | A   | 200 | 150 | 13   | 200 | 670 | 400 | 550 | NA  | 150 | 30 | 240 | 180 | NA | 650  | 530  | NA  | 483.5 | 27 | 19 | 140 | 60 | 110   | 64.4 | 18 | 180 |
| 137A1   | KFD150/28            | A   | 200 | 150 | 13   | 178 | 670 | 280 | 375 | NA  | 100 | 20 | 200 | 150 | NA | 500  | 400  | NA  | 484   | 27 | 19 | 140 | 60 | 123   | 64.4 | 18 | 180 |
| 13782   | KFD200/36            | C   | 200 | 200 | 13   | 200 | 680 | 370 | 315 | 282 | 100 | 25 | 335 | 265 | NA | 530  | 560  | NA  | 503.5 | 33 | 19 | 140 | 60 | 122.5 | 64.4 | 16 | 180 |
| 137C1   | KFD250/33A           | C   | 250 | 250 | 13   | 220 | 690 | 400 | 320 | 295 | 120 | 30 | 350 | 280 | NA | 750  | 630  | 350 | 503.5 | 33 | 19 | 140 | 60 | 123   | 64.4 | 18 | 180 |
| 137C2   | KFD250/38            | C   | 250 | 25  | 13   | 220 | 690 | 430 | 350 | 310 | 120 | 30 | 350 | 280 | NA | 800  | 680  | 380 | 504   | 33 | 19 | 140 | 60 | 123   | 64   | 18 | 180 |
| 137C3   | KFD250/50            | A   | 300 | 250 | 15   | 200 | 720 | 475 | 670 | NA  | 150 | 30 | 260 | 190 | NA | 800  | 670  | NA  | 515   | 28 | 19 | 140 | 60 | 130   | 64.4 | 18 | 180 |
| 137C4   | KFD250/40            | A   | 300 | 250 | 15   | 200 | 720 | 425 | 600 | NA  | 130 | 30 | 260 | 190 | NA | 800  | 670  | NA  | 515   | 28 | 19 | 140 | 60 | 130   | 64.4 | 18 | 180 |
| 137D2   | KFD150/56            | D   | 200 | 150 | 19   | 200 | 930 | 415 | 575 | NA  | 200 | 32 | 250 | 180 | NA | 900  | 750  | NA  | 710   | 28 | 18 | 140 | 75 | 147   | 79.9 | 20 | 260 |
| 137G1   | KFD350/40            | D   | 400 | 350 | 19   | 300 | 930 | 500 | 675 | NA  | 225 | 40 | 400 | 300 | NA | 1250 | 1170 | NA  | 710   | 28 | 18 | 140 | 75 | 147   | 79.9 | 20 | 315 |



| INTERCHANGEABILITY CHART OF KPDF, KPD CLM, KPDQF-J PUMPS...(DRIVING UNIT NO. KPD - 4) |  |                   |        |     |          |        |     |          |        |     |          |
|---|--|-------------------|--------|-----|----------|--------|-----|----------|--------|-----|----------|
| PART NO.  | PUMP SIZE<br><br>PART DESCRIPTION              | TOTAL NO.OF PARTS | 20/12  |     |          | 20/16  |     |          | 20/20  |     |          |
|   |  |                   | KPD-QF | CLM | KPD-QF-J | KPD-QF | CLM | KPD-QF-J | KPD-QF | CLM | KPD-QF-J |
| 105   | PUMP CASING FOOT MOUNTED                       | 3                 | 1      |     |          | 2      |     |          | 3      |     |          |
| 106   | PUMP CASING CENTRE LINE MOUNTED                | 3                 | 1      |     |          | 2      |     |          | 3      |     |          |
| 133   | SEMI OPEN IMPELLER                             | 3                 | 1      |     |          | 2      |     |          | 3      |     |          |
| 180.1   | PUMP SHAFT WITH DEEP GROOVE BRG.               | 1                 | 1      |     |          | 1      |     |          | 1      |     |          |
| 180.2   | PUMP SHAFT WITH REINFORCED BRG. ARRGT.         | 1                 | 1      |     |          | 1      |     |          | 1      |     |          |
| 190   | CASING WEAR RING (SUCTION)                     | NA                | NA     |     |          | NA     |     |          | NA     |     |          |
| 191   | CASING WEAR RING (DEL)                         | NA                | NA     |     |          | NA     |     |          | NA     |     |          |
| 192   | IMPELLER WEAR RING (SUC)                       | NA                | NA     |     |          | NA     |     |          | NA     |     |          |
| 193   | IMPELLER RING (DEL)                            | NA                | NA     |     |          | NA     |     |          | NA     |     |          |
| 209   | SPACER RING                                    | 1                 | 1      |     |          | 1      |     |          | 1      |     |          |
| 220   | CASING COVER                                   | 3                 | 1      |     |          | 2      |     |          | 3      |     |          |
| 226   | DRIF FAN                                       | 1                 | 1      |     |          | 1      |     |          | 1      |     |          |
| 227   | LANTERN RING                                   | 1                 | 1      |     |          | 1      |     |          | 1      |     |          |
| 229   | SPIT GLAND                                     | 1                 | 1      |     |          | 1      |     |          | 1      |     |          |
| 236   | LIQUID DEFLECTOR                               | 1                 | 1      |     |          | 1      |     |          | 1      |     |          |
| 240   | BEARING HOUSING (STD.)                         | 1                 | 1      |     |          | 1      |     |          | 1      |     |          |
| 241   | BEARING CARTRIDGE                              | 1                 | 1      |     |          | 1      |     |          | 1      |     |          |
| 252   | BEARING HOUSING (WITH COOLING)                 | 1                 | 1      |     |          | 1      |     |          | 1      |     |          |
| 251   | SUPPORT FOOT FOR FOOT MOUNTED                  | 3                 | 1      |     |          | 2      |     |          | 3      |     |          |
| 251   | SUPPORT FOOT FOR CENTRE LINE MOUNTED           | 3                 | 1      |     |          | 2      |     |          | 3      |     |          |
| 260.1,260.2   | DEEP GROOVE BALL BEARING D.S. & P.S.           | 1                 | 1      |     |          | 1      |     |          | 1      |     |          |
| 263   | ANGULAR CONTACT BALL BEARING                   | 1                 | 1      |     |          | 1      |     |          | 1      |     |          |
| 264   | CYLINDRICAL ROLLER BEARING                     | 1                 | 1      |     |          | 1      |     |          | 1      |     |          |
| 270   | BEARING COVER N.D.S.                           | 1                 | 1      |     |          | 1      |     |          | 1      |     |          |
| 311   | SHAFT SLEEVE                                   | 1                 | 1      |     |          | 1      |     |          | 1      |     |          |
| 330   | IMPELLER NUT                                   | NA                | NA     |     |          | NA     |     |          | NA     |     |          |
| 350   | ST. BOX BUSH                                   | 1                 | 1      |     |          | 1      |     |          | 1      |     |          |
| 367   | OIL WELL COVER FOR BRG.OIL COOLING             | 1                 | 1      |     |          | 1      |     |          | 1      |     |          |
| 430   | GLAND PACKING                                  | 1                 | 1      |     |          | 1      |     |          | 1      |     |          |
| 443   | CONSTANT LEVEL OILER                           | 1                 | 1      |     |          | 1      |     |          | 1      |     |          |
| 480   | WEAR PLATE SUC. SIDE                           | NA                | NA     |     |          | NA     |     |          | NA     |     |          |
| 511   | GASKET FOR CASING COVER                        | 3                 | 1      |     |          | 2      |     |          | 3      |     |          |
| 514   | GASKET FOR BRG.COVER D.S                       | 1                 | 1      |     |          | 1      |     |          | 1      |     |          |
| 515   | GASKET FOR SHAFT SLEEVE                        | 1                 | 1      |     |          | 1      |     |          | 1      |     |          |
| 523   | O-RING FOR BEARING HOUSING AND LANTERN BRACKET | 1                 | 1      |     |          | 1      |     |          | 1      |     |          |
| 523.1   | O' RING FOR CASING COVER                       | 1                 | 1      |     |          | 1      |     |          | 1      |     |          |
| 523.2   | O' RING FOR LANTERN BRACKET                    | 1                 | 1      |     |          | 1      |     |          | 1      |     |          |





**INTERCHANGEABILITY CHART OF KPD, KPDQF, KPD CLM, KPD-J, AND KPDQF-J PUMPS... (DRIVING UNIT NO. KPD - 5)**

| PART NO.     | PUMP SIZE | PART DESCRIPTION                       | TOTAL NO. OF PARTS | 32/13 |        | 40/13  |        | 50/13  |        | 65/13  |        | 25/16  |        | 32/16  |        | 40/16  |        | 50/16  |        | 32/20  |        | 40/20  |        | 50/20  |        |        |
|--------------|-----------|--|--------------------|-------|--------|--------|--------|--------|--------|--------|--------|--------|--------|--------|--------|--------|--------|--------|--------|--------|--------|--------|--------|--------|--------|--------|
|              |           |  |                    | KPD   | KPD-QF | KPD-QF | KPD-QF | KPD-QF | KPD-QF | KPD-QF | KPD-QF | KPD-QF | KPD-QF | KPD-QF | KPD-QF | KPD-QF | KPD-QF | KPD-QF | KPD-QF | KPD-QF | KPD-QF | KPD-QF | KPD-QF | KPD-QF | KPD-QF | KPD-QF |
| 105          |           | PUMP CASING FOOT MOUNTED               | 22                 | 1     | 1      | 2      | 3      | 3      | 4      | 5      | 5      | 6      | 7      | 7      | 8      | 9      | 9      | 10     | 11     | 11     | 12     | 13     | 13     | 14     | 15     | 15     |
| 106          |           | PUMP CASING CENTRE LINE MOUNTED        | 11                 | 1     | 1      | 1      | 2      | 2      | 2      | 2      | 2      | 2      | 2      | 2      | 2      | 2      | 2      | 2      | 2      | 2      | 2      | 2      | 2      | 2      | 2      |        |
| 151          |           | ENCLOSED IMPELLER                      | 10                 | 1     | 1      | 2      | 2      | 3      | 3      | 3      | 4      | 4      | 4      | 4      | 5      | 5      | 6      | 6      | 7      | 7      | 8      | 8      | 9      | 9      | 10     |        |
| 153          |           | SEMI OPEN IMPELLER                     | 11                 | 1     | 1      | 2      | 2      | 3      | 3      | 4      | 4      | 4      | 4      | 5      | 5      | 6      | 7      | 7      | 8      | 8      | 9      | 9      | 10     | 10     | 11     |        |
| 160.1        |           | PUMP SHAFT WITH DEEP GROOVE BRG.       | 1                  | 1     | 1      | 1      | 1      | 1      | 1      | 1      | 1      | 1      | 1      | 1      | 1      | 1      | 1      | 1      | 1      | 1      | 1      | 1      | 1      | 1      | 1      |        |
| 180.2        |           | PUMP SHAFT WITH REINFORCED DRG. ARRGT. | 1                  | 1     | 1      | 1      | 1      | 1      | 1      | 1      | 1      | 1      | 1      | 1      | 1      | 1      | 1      | 1      | 1      | 1      | 1      | 1      | 1      | 1      | 1      |        |
| 180          |           | CASING WEAR RING (SUCTION)             | 4                  | 1     | 1      | 1      | 2      | 2      | 3      | 3      | 3      | 4      | 4      | 4      | 4      | 4      | 4      | 4      | 4      | 4      | 4      | 4      | 4      | 4      | 4      |        |
| 191          |           | CASING WEAR RING (DEU)                 | NA                 |       |        |        |        |        |        |        |        |        |        |        |        |        |        |        |        |        |        |        |        |        |        |        |
| 192          |           | IMPELLER WEAR RING (SUC)               | 4                  | 1     | 1      | 1      | 2      | 2      | 3      | 3      | 3      | 4      | 4      | 4      | 4      | 4      | 4      | 4      | 4      | 4      | 4      | 4      | 4      | 4      | 4      |        |
| 193          |           | IMPELLER RING (DEU)                    | NA                 |       |        |        |        |        |        |        |        |        |        |        |        |        |        |        |        |        |        |        |        |        |        |        |
| 220          |           | CASING COVER                           | 18                 | 1     | 2      | 3      | 4      | 4      | 4      | 4      | 4      | 4      | 4      | 4      | 4      | 4      | 4      | 4      | 4      | 4      | 4      | 4      | 4      | 4      | 4      |        |
| 220          |           | DRIP PAN                               | 3                  | 1     | 1      | 1      | 1      | 1      | 1      | 1      | 1      | 1      | 1      | 1      | 1      | 1      | 1      | 1      | 1      | 1      | 1      | 1      | 1      | 1      | 1      |        |
| 227          |           | LANTERN RING                           | 1                  | 1     | 1      | 1      | 1      | 1      | 1      | 1      | 1      | 1      | 1      | 1      | 1      | 1      | 1      | 1      | 1      | 1      | 1      | 1      | 1      | 1      | 1      |        |
| 229          |           | SPT GLAND                              | 1                  | 1     | 1      | 1      | 1      | 1      | 1      | 1      | 1      | 1      | 1      | 1      | 1      | 1      | 1      | 1      | 1      | 1      | 1      | 1      | 1      | 1      | 1      |        |
| 236          |           | LIQUID DEFLECTOR                       | 1                  | 1     | 1      | 1      | 1      | 1      | 1      | 1      | 1      | 1      | 1      | 1      | 1      | 1      | 1      | 1      | 1      | 1      | 1      | 1      | 1      | 1      | 1      |        |
| 240          |           | BEARING HOUSING (STD)                  | 1                  | 1     | 1      | 1      | 1      | 1      | 1      | 1      | 1      | 1      | 1      | 1      | 1      | 1      | 1      | 1      | 1      | 1      | 1      | 1      | 1      | 1      | 1      |        |
| 241          |           | BEARING CARTRIDGE                      | 1                  | 1     | 1      | 1      | 1      | 1      | 1      | 1      | 1      | 1      | 1      | 1      | 1      | 1      | 1      | 1      | 1      | 1      | 1      | 1      | 1      | 1      | 1      |        |
| 252          |           | BEARING HOUSING WITH COOLING           | 1                  | 1     | 1      | 1      | 1      | 1      | 1      | 1      | 1      | 1      | 1      | 1      | 1      | 1      | 1      | 1      | 1      | 1      | 1      | 1      | 1      | 1      | 1      |        |
| 248          |           | LANTERN BRACKET                        | 3                  | 1     | 1      | 1      | 1      | 1      | 1      | 1      | 1      | 1      | 1      | 1      | 1      | 1      | 1      | 1      | 1      | 1      | 1      | 1      | 1      | 1      | 1      |        |
| 251          |           | SUPPORT FOOT FOR FOOT MOUNTED          | 3                  | 1     | 1      | 1      | 1      | 1      | 1      | 1      | 1      | 1      | 1      | 1      | 1      | 1      | 1      | 1      | 1      | 1      | 1      | 1      | 1      | 1      | 1      |        |
| 251          |           | SUPPORT FOOT FOR CENTRE LINE MOUNTED   | 1                  | 1     | 1      | 1      | 1      | 1      | 1      | 1      | 1      | 1      | 1      | 1      | 1      | 1      | 1      | 1      | 1      | 1      | 1      | 1      | 1      | 1      | 1      |        |
| 260.1, 260.2 |           | DEEP GROOVE BALL BEARING D.S. & P.S.   | 1                  | 1     | 1      | 1      | 1      | 1      | 1      | 1      | 1      | 1      | 1      | 1      | 1      | 1      | 1      | 1      | 1      | 1      | 1      | 1      | 1      | 1      | 1      |        |
| 263          |           | ANGULAR CONTACT BALL BEARING           | 1                  | 1     | 1      | 1      | 1      | 1      | 1      | 1      | 1      | 1      | 1      | 1      | 1      | 1      | 1      | 1      | 1      | 1      | 1      | 1      | 1      | 1      | 1      |        |
| 264          |           | CYLINDRICAL ROLLER BEARING             | 1                  | 1     | 1      | 1      | 1      | 1      | 1      | 1      | 1      | 1      | 1      | 1      | 1      | 1      | 1      | 1      | 1      | 1      | 1      | 1      | 1      | 1      | 1      |        |
| 270          |           | BEARING COVER D.S.                     | 1                  | 1     | 1      | 1      | 1      | 1      | 1      | 1      | 1      | 1      | 1      | 1      | 1      | 1      | 1      | 1      | 1      | 1      | 1      | 1      | 1      | 1      | 1      |        |
| 311          |           | SHAFT SLEEVE                           | 1                  | 1     | 1      | 1      | 1      | 1      | 1      | 1      | 1      | 1      | 1      | 1      | 1      | 1      | 1      | 1      | 1      | 1      | 1      | 1      | 1      | 1      | 1      |        |
| 330          |           | IMPELLER NUT                           | 1                  | 1     | 1      | 1      | 1      | 1      | 1      | 1      | 1      | 1      | 1      | 1      | 1      | 1      | 1      | 1      | 1      | 1      | 1      | 1      | 1      | 1      | 1      |        |
| 360          |           | ST. BOX BUSH                           | 1                  | 1     | 1      | 1      | 1      | 1      | 1      | 1      | 1      | 1      | 1      | 1      | 1      | 1      | 1      | 1      | 1      | 1      | 1      | 1      | 1      | 1      | 1      |        |
| 367          |           | OIL WELL COVER FOR BRG.OIL COOLING     | 1                  | 1     | 1      | 1      | 1      | 1      | 1      | 1      | 1      | 1      | 1      | 1      | 1      | 1      | 1      | 1      | 1      | 1      | 1      | 1      | 1      | 1      | 1      |        |
| 430          |           | GLAND PACKING                          | 1                  | 1     | 1      | 1      | 1      | 1      | 1      | 1      | 1      | 1      | 1      | 1      | 1      | 1      | 1      | 1      | 1      | 1      | 1      | 1      | 1      | 1      | 1      |        |
| 443          |           | CONSTANT LEVEL OILER                   | 1                  | 1     | 1      | 1      | 1      | 1      | 1      | 1      | 1      | 1      | 1      | 1      | 1      | 1      | 1      | 1      | 1      | 1      | 1      | 1      | 1      | 1      | 1      |        |
| 460          |           | WEAR RATE SUC. SIZE                    | 11                 | 1     | 1      | 2      | 2      | 3      | 3      | 3      | 4      | 4      | 4      | 4      | 5      | 5      | 6      | 6      | 6      | 6      | 6      | 6      | 6      | 6      | 6      |        |
| 511          |           | GASKET FOR CASING COVER                | 3                  | 1     | 1      | 1      | 1      | 1      | 1      | 1      | 1      | 1      | 1      | 1      | 1      | 1      | 1      | 1      | 1      | 1      | 1      | 1      | 1      | 1      | 1      |        |
| 514          |           | GASKET FOR BRG. COVER D.S.             | 1                  | 1     | 1      | 1      | 1      | 1      | 1      | 1      | 1      | 1      | 1      | 1      | 1      | 1      | 1      | 1      | 1      | 1      | 1      | 1      | 1      | 1      | 1      |        |
| 515          |           | GASKET FOR SHAFT SLEEVE                | 1                  | 1     | 1      | 1      | 1      | 1      | 1      | 1      | 1      | 1      | 1      | 1      | 1      | 1      | 1      | 1      | 1      | 1      | 1      | 1      | 1      | 1      | 1      |        |
| 525.1        |           | 'O' RING FOR CASING COVER              | 1                  | 1     | 1      | 1      | 1      | 1      | 1      | 1      | 1      | 1      | 1      | 1      | 1      | 1      | 1      | 1      | 1      | 1      | 1      | 1      | 1      | 1      | 1      |        |
| 525.2        |           | 'O' RING FOR LANTERN BRACKET           | 3                  | 1     | 1      | 1      | 1      | 1      | 1      | 1      | 1      | 1      | 1      | 1      | 1      | 1      | 1      | 1      | 1      | 1      | 1      | 1      | 1      | 1      | 1      |        |
| 662          |           | GASKET FOR IMPELLER NUT                | 1                  | 1     | 1      | 1      | 1      | 1      | 1      | 1      | 1      | 1      | 1      | 1      | 1      | 1      | 1      | 1      | 1      | 1      | 1      | 1      | 1      | 1      | 1      |        |



**INTERCHANGEABILITY CHART OF KPD, KPDOF, KPD CLM, KPD-J, AND KPDOF-J PUMPS... (DRIVING UNIT NO. KPD-7)**

| PART NO. | PUMP SIZE                               | TOTAL NO. OF |       |       |       |       |       |       |       |       |       |       |       |        |        |
|----------|---|--------------|-------|-------|-------|-------|-------|-------|-------|-------|-------|-------|-------|--------|--------|
|          |   | 25/26A       | 32/26 | 40/26 | 40/32 | 50/26 | 50/32 | 60/14 | 60/26 | 60/32 | 60/16 | 60/26 | 60/32 | 100/16 | 100/20 |
| 105      | PUMP CASING FOOT MOUNTED                | 28           | 1     | 1     | 1     | 1     | 1     | 1     | 1     | 1     | 1     | 1     | 1     | 1      | 1      |
| 106      | PUMP CASING CENTRE LINE MOUNTED         | 15           | 1     | 1     | 1     | 1     | 1     | 1     | 1     | 1     | 1     | 1     | 1     | 1      |        |
| 151      | ENCLOSED IMPELLER                       | 15           | 1     | 1     | 1     | 1     | 1     | 1     | 1     | 1     | 1     | 1     | 1     | 1      |        |
| 153      | SEMI OPEN IMPELLER                      | 12           | 1     | 1     | 1     | 1     | 1     | 1     | 1     | 1     | 1     | 1     | 1     | 1      |        |
| 180.1    | PUMP SHAFT WITH DEEP GROOVE BRG.        | 1            | 1     | 1     | 1     | 1     | 1     | 1     | 1     | 1     | 1     | 1     | 1     | 1      |        |
| 180.2    | PUMP SHAFT WITH REINFORCED DRG. ARREST. | 1            | 1     | 1     | 1     | 1     | 1     | 1     | 1     | 1     | 1     | 1     | 1     | 1      |        |
| 190      | CASING WEAR RING SUCTION                | 11           | 1     | 1     | 1     | 1     | 1     | 1     | 1     | 1     | 1     | 1     | 1     | 1      |        |
| 191      | CASING WEARING BEEL                     | 2            | 1     | 1     | 1     | 1     | 1     | 1     | 1     | 1     | 1     | 1     | 1     | 1      |        |
| 192      | IMPELLER WEAR RING (S&C)                | 11           | 1     | 1     | 1     | 1     | 1     | 1     | 1     | 1     | 1     | 1     | 1     | 1      |        |
| 193      | IMPELLER BRG BEEL                       | 2            | 1     | 1     | 1     | 1     | 1     | 1     | 1     | 1     | 1     | 1     | 1     | 1      |        |
| 220      | CASING COVER                            | 1            | 1     | 1     | 1     | 1     | 1     | 1     | 1     | 1     | 1     | 1     | 1     | 1      |        |
| 226      | DISP PAN                                | 3            | 1     | 1     | 1     | 1     | 1     | 1     | 1     | 1     | 1     | 1     | 1     | 1      |        |
| 227      | LANTERN RING                            | 1            | 1     | 1     | 1     | 1     | 1     | 1     | 1     | 1     | 1     | 1     | 1     | 1      |        |
| 229      | SPT GLAND                               | 1            | 1     | 1     | 1     | 1     | 1     | 1     | 1     | 1     | 1     | 1     | 1     | 1      |        |
| 236      | SOUND DETECTOR                          | 1            | 1     | 1     | 1     | 1     | 1     | 1     | 1     | 1     | 1     | 1     | 1     | 1      |        |
| 240      | BEARING HOUSING (STD.)                  | 2            | 1     | 1     | 1     | 1     | 1     | 1     | 1     | 1     | 1     | 1     | 1     | 1      |        |
| 241      | BEARING HOUSING (WITH COOLING)          | 1            | 1     | 1     | 1     | 1     | 1     | 1     | 1     | 1     | 1     | 1     | 1     | 1      |        |
| 248      | LANTERN BRACKET                         | 3            | 1     | 1     | 1     | 1     | 1     | 1     | 1     | 1     | 1     | 1     | 1     | 1      |        |
| 251      | SUPPORT FOOT FOR FOOT MOUNTED           | 5            | 1     | 1     | 1     | 1     | 1     | 1     | 1     | 1     | 1     | 1     | 1     | 1      |        |
| 251      | SUPPORT FOOT FOR CENTRE LINE MOUNTED    | 3            | 1     | 1     | 1     | 1     | 1     | 1     | 1     | 1     | 1     | 1     | 1     | 1      |        |
| 260      | DEEP GROOVE BALL BEARING D.S. & P.S.    | NA           | NA    | NA    | NA    | NA    | NA    | NA    | NA    | NA    | NA    | NA    | NA    | NA     |        |
| 263      | ANGULAR CONTACT BALL BEARING            | 1            | 1     | 1     | 1     | 1     | 1     | 1     | 1     | 1     | 1     | 1     | 1     | 1      |        |
| 264      | CYLINDRICAL ROLLER BEARING              | 1            | 1     | 1     | 1     | 1     | 1     | 1     | 1     | 1     | 1     | 1     | 1     | 1      |        |
| 270      | BEARING COVER D.S.                      | 1            | 1     | 1     | 1     | 1     | 1     | 1     | 1     | 1     | 1     | 1     | 1     | 1      |        |
| 311      | SHAFT SLEEVES                           | 1            | 1     | 1     | 1     | 1     | 1     | 1     | 1     | 1     | 1     | 1     | 1     | 1      |        |
| 330      | IMPELLER NUT                            | 1            | 1     | 1     | 1     | 1     | 1     | 1     | 1     | 1     | 1     | 1     | 1     | 1      |        |
| 360      | ST. BOX BUSH                            | 1            | 1     | 1     | 1     | 1     | 1     | 1     | 1     | 1     | 1     | 1     | 1     | 1      |        |
| 367      | OIL WELL COVER FOR BRG. OIL COOLING     | 1            | 1     | 1     | 1     | 1     | 1     | 1     | 1     | 1     | 1     | 1     | 1     | 1      |        |
| 430      | GLAND PACKING                           | 1            | 1     | 1     | 1     | 1     | 1     | 1     | 1     | 1     | 1     | 1     | 1     | 1      |        |
| 443      | CONSTANT LEVEL ORER                     | 1            | 1     | 1     | 1     | 1     | 1     | 1     | 1     | 1     | 1     | 1     | 1     | 1      |        |
| 460      | WEAR PLATE BUC. SIDE                    | 12           | NA    | 1     | 1     | 1     | 1     | 1     | 1     | 1     | 1     | 1     | 1     | 1      |        |
| 511      | BASKET FOR CASING COVER                 | 9            | 1     | 1     | 1     | 1     | 1     | 1     | 1     | 1     | 1     | 1     | 1     | 1      |        |
| 514      | BASKET FOR BRG. COVER D.S.              | 1            | 1     | 1     | 1     | 1     | 1     | 1     | 1     | 1     | 1     | 1     | 1     | 1      |        |
| 515      | BASKET FOR SHAFT SLEEVE                 | 1            | 1     | 1     | 1     | 1     | 1     | 1     | 1     | 1     | 1     | 1     | 1     | 1      |        |
| 525.1    | 'O' RING FOR CASING COVER               | 1            | 1     | 1     | 1     | 1     | 1     | 1     | 1     | 1     | 1     | 1     | 1     | 1      |        |
| 525.2    | 'O' RING FOR LANTERN BRACKET            | 1            | 1     | 1     | 1     | 1     | 1     | 1     | 1     | 1     | 1     | 1     | 1     | 1      |        |
| 682      | BASKET FOR IMPELLER NUT                 | 1            | 1     | 1     | 1     | 1     | 1     | 1     | 1     | 1     | 1     | 1     | 1     | 1      |        |



Enriching Lives

**INTERCHANGEABILITY CHART OF KPD, KPDOF, KPD C.M., KPD-J, AND KPDOF-J PUMPS ... (DRIVING UNIT NO. KPD - 9)**

| PART NO.    | PUMP SIZE                               | PART DESCRIPTION | TOTAL NO. OF |       |        |        |        |        |                |                |        |         |         |        |       |        |        |        |
|-------------|---|------------------|--------------|-------|--------|--------|--------|--------|----------------|----------------|--------|---------|---------|--------|-------|--------|--------|--------|
|             |   |                  | 85-22        | 80-60 | 80-90N | 100-26 | 100-32 | 100-40 | 120-26 1500RPM | 120-32 1500RPM | 125-60 | 125-90N | 150-32N | 150-60 | 80-32 | 150-20 | 150-26 | 150-32 |
| 105         | PUMP CASING FOOT MOUNTED                | 25               | 1            | 1     | 1      | 1      | 1      | 1      | 1              | 1              | 1      | 1       | 1       | 1      | 1     | 1      | 1      | 1      |
| 106         | PUMP CASING CENTRE LINE MOUNTED         | 14               | 1            | 1     | 1      | 1      | 1      | 1      | 1              | 1              | 1      | 1       | 1       | 1      | 1     | 1      | 1      | 1      |
| 191         | ENCLOSED IMPELLER                       | 17               | 1            | 1     | 1      | 1      | 1      | 1      | 1              | 1              | 1      | 1       | 1       | 1      | 1     | 1      | 1      | 1      |
| 193         | SEM OPEN IMPELLER                       | 10               | 1            | 1     | 1      | 1      | 1      | 1      | 1              | 1              | 1      | 1       | 1       | 1      | 1     | 1      | 1      | 1      |
| 180.1       | PUMP SHAFT WITH DEEP GROOVE BRG.        | 1                | 1            | 1     | 1      | 1      | 1      | 1      | 1              | 1              | 1      | 1       | 1       | 1      | 1     | 1      | 1      | 1      |
| 180.2       | PUMP SHAFT WITH REINFORCED DRG. APPROX. | 1                | 1            | 1     | 1      | 1      | 1      | 1      | 1              | 1              | 1      | 1       | 1       | 1      | 1     | 1      | 1      | 1      |
| 190         | CASING WEAR RING (BUCTION)              | 9                | 1            | 1     | 1      | 1      | 1      | 1      | 1              | 1              | 1      | 1       | 1       | 1      | 1     | 1      | 1      | 1      |
| 191         | CASING WEAR RING (D.B.)                 | 8                | 1            | 1     | 1      | 1      | 1      | 1      | 1              | 1              | 1      | 1       | 1       | 1      | 1     | 1      | 1      | 1      |
| 192         | IMPELLER WEARING RING (B.O.)            | 9                | 1            | 1     | 1      | 1      | 1      | 1      | 1              | 1              | 1      | 1       | 1       | 1      | 1     | 1      | 1      | 1      |
| 193         | IMPELLER WEARING RING (D.B.)            | 4                | 1            | 1     | 1      | 1      | 1      | 1      | 1              | 1              | 1      | 1       | 1       | 1      | 1     | 1      | 1      | 1      |
| 220         | CASING COVER                            | 13               | 1            | 1     | 1      | 1      | 1      | 1      | 1              | 1              | 1      | 1       | 1       | 1      | 1     | 1      | 1      | 1      |
| 226         | IMPELLER NUT                            | 2                | 1            | 1     | 1      | 1      | 1      | 1      | 1              | 1              | 1      | 1       | 1       | 1      | 1     | 1      | 1      | 1      |
| 227         | LANTERN RING                            | 1                | 1            | 1     | 1      | 1      | 1      | 1      | 1              | 1              | 1      | 1       | 1       | 1      | 1     | 1      | 1      | 1      |
| 229         | IMPELLER NUT                            | 1                | 1            | 1     | 1      | 1      | 1      | 1      | 1              | 1              | 1      | 1       | 1       | 1      | 1     | 1      | 1      | 1      |
| 236         | LIQUID DEFLECTOR                        | 2                | 1            | 1     | 1      | 1      | 1      | 1      | 1              | 1              | 1      | 1       | 1       | 1      | 1     | 1      | 1      | 1      |
| 240         | BEARING HOUSING (B.T.O.)                | 2                | 1            | 1     | 1      | 1      | 1      | 1      | 1              | 1              | 1      | 1       | 1       | 1      | 1     | 1      | 1      | 1      |
| 241         | BEARING CARTRIDGE                       | 1                | 1            | 1     | 1      | 1      | 1      | 1      | 1              | 1              | 1      | 1       | 1       | 1      | 1     | 1      | 1      | 1      |
| 252         | BEARING HOUSING WITH COOLING            | 1                | 1            | 1     | 1      | 1      | 1      | 1      | 1              | 1              | 1      | 1       | 1       | 1      | 1     | 1      | 1      | 1      |
| 246         | LANTERN BRACKET                         | 3                | 1            | 1     | 1      | 1      | 1      | 1      | 1              | 1              | 1      | 1       | 1       | 1      | 1     | 1      | 1      | 1      |
| 248         | SUPPORT FOOT FOR FOOT MOUNTED           | 4                | 1            | 1     | 1      | 1      | 1      | 1      | 1              | 1              | 1      | 1       | 1       | 1      | 1     | 1      | 1      | 1      |
| 251         | SUPPORT FOOT FOR CENTRE LINE MOUNTED    | 4                | 1            | 1     | 1      | 1      | 1      | 1      | 1              | 1              | 1      | 1       | 1       | 1      | 1     | 1      | 1      | 1      |
| 260.1,260.2 | DEEP GROOVE BALL BEARING D.S. & P.S.L.  | 1                | 1            | 1     | 1      | 1      | 1      | 1      | 1              | 1              | 1      | 1       | 1       | 1      | 1     | 1      | 1      | 1      |
| 263         | ANGULAR CONTACT BALL BEARING            | 1                | 1            | 1     | 1      | 1      | 1      | 1      | 1              | 1              | 1      | 1       | 1       | 1      | 1     | 1      | 1      | 1      |
| 264         | CYRINDRICAL ROLLER BEARING              | 1                | 1            | 1     | 1      | 1      | 1      | 1      | 1              | 1              | 1      | 1       | 1       | 1      | 1     | 1      | 1      | 1      |
| 270         | BEARING COVER D.S.                      | 1                | 1            | 1     | 1      | 1      | 1      | 1      | 1              | 1              | 1      | 1       | 1       | 1      | 1     | 1      | 1      | 1      |
| 311         | SHAFT SLEEVE                            | 2                | 1            | 1     | 1      | 1      | 1      | 1      | 1              | 1              | 1      | 1       | 1       | 1      | 1     | 1      | 1      | 1      |
| 330         | IMPELLER NUT                            | 1                | 1            | 1     | 1      | 1      | 1      | 1      | 1              | 1              | 1      | 1       | 1       | 1      | 1     | 1      | 1      | 1      |
| 350         | ST. BOX BUSH                            | 1                | 1            | 1     | 1      | 1      | 1      | 1      | 1              | 1              | 1      | 1       | 1       | 1      | 1     | 1      | 1      | 1      |
| 367         | SH. WEL COVER FOR BRG. & COOLING        | 1                | 1            | 1     | 1      | 1      | 1      | 1      | 1              | 1              | 1      | 1       | 1       | 1      | 1     | 1      | 1      | 1      |
| 430         | ISLAND PACKING                          | 1                | 1            | 1     | 1      | 1      | 1      | 1      | 1              | 1              | 1      | 1       | 1       | 1      | 1     | 1      | 1      | 1      |
| 443         | CONSTANT LEVEL LOWER                    | 1                | 1            | 1     | 1      | 1      | 1      | 1      | 1              | 1              | 1      | 1       | 1       | 1      | 1     | 1      | 1      | 1      |
| 460         | WEAR PLATE S.U.C. SIDE                  | 10               | 1            | 1     | 1      | 1      | 1      | 1      | 1              | 1              | 1      | 1       | 1       | 1      | 1     | 1      | 1      | 1      |
| 511         | GASKET FOR CASING COVER                 | 9                | 1            | 1     | 1      | 1      | 1      | 1      | 1              | 1              | 1      | 1       | 1       | 1      | 1     | 1      | 1      | 1      |
| 514         | GASKET FOR IMPELLER D.S.                | 1                | 1            | 1     | 1      | 1      | 1      | 1      | 1              | 1              | 1      | 1       | 1       | 1      | 1     | 1      | 1      | 1      |
| 515         | GASKET FOR IMPELLER P.S.L.              | 1                | 1            | 1     | 1      | 1      | 1      | 1      | 1              | 1              | 1      | 1       | 1       | 1      | 1     | 1      | 1      | 1      |
| 526.1       | O-RING FOR CASING COVER                 | 1                | 1            | 1     | 1      | 1      | 1      | 1      | 1              | 1              | 1      | 1       | 1       | 1      | 1     | 1      | 1      | 1      |
| 526.2       | O-RING FOR IMPELLER BRACKET             | 1                | 1            | 1     | 1      | 1      | 1      | 1      | 1              | 1              | 1      | 1       | 1       | 1      | 1     | 1      | 1      | 1      |
| 662         | GASKET FOR IMPELLER NUT                 | 1                | 1            | 1     | 1      | 1      | 1      | 1      | 1              | 1              | 1      | 1       | 1       | 1      | 1     | 1      | 1      | 1      |



| INTERCHANGEABILITY CHART OF KPD, KPD CLM, KPD-J PUMPS...(DRIVING UNIT NO. KPD - 11) |           |  |              |         |     |       |          |     |       |                |     |       |        |     |       |        |     |       |        |     |       |
|---|-----------|--|--------------|---------|-----|-------|----------|-----|-------|----------------|-----|-------|--------|-----|-------|--------|-----|-------|--------|-----|-------|
| PART NO.  | PUMP SIZE | PART DESCRIPTION                       | TOTAL NO. OF | 80+40CV |     |       | 100+40CV |     |       | 125 99-2900RPM |     |       | 125+45 |     |       | 150+48 |     |       | 200 03 |     |       |
|   |           |  |              | KPD     | CLM | KPD-J | KPD      | CLM | KPD-J | KPD            | CLM | KPD-J | KPD    | CLM | KPD-J | KPD    | CLM | KPD-J | KPD    | CLM | KPD-J |
| 105   |           | PUMP CASING FOOT MOUNTED               | 12           | 1       | 1   | 2     | 1        | 1   | 4     | 1              | 1   | 1     | 1      | 1   | 1     | 1      | 1   | 1     | 1      | 1   |       |
| 106   |           | PUMP CASING CENTRE LINE MOUNTED        | 0            | -       | -   | -     | -        | -   | -     | -              | -   | -     | -      | -   | -     | -      | -   | -     | -      |     |       |
| 151   |           | ENCLOSED IMPELLER                      | 0            | 1       |     | 2     |          | 2   |       | 4              |     | 5     |        | 6   |       |        |     |       |        |     |       |
| 180.1   |           | PUMP SHAFT WITH DEEP GROOVE BRG.       | 4            | 1       |     | 1     |          | 1   |       | 2              |     | 3     |        | 4   |       |        |     |       |        |     |       |
| 180.2   |           | PUMP SHAFT WITH REINFORCED DRG. AXKIT. | 4            | 1       |     | 1     |          | 1   |       | 2              |     | 3     |        | 4   |       |        |     |       |        |     |       |
| 190   |           | CASING WEAR RING (BUCTION)             | 5            | 1       |     | 1     |          | 2   |       | 3              |     | 4     |        | 5   |       |        |     |       |        |     |       |
| 191   |           | CASING WEAR RING (DIL)                 | 4            | 1       |     | 1     |          | NA  |       | 2              |     | 3     |        | 4   |       |        |     |       |        |     |       |
| 192   |           | IMPELLER WEAR RING (BUC)               | 5            | 1       |     | 1     |          | 2   |       | 3              |     | 4     |        | 5   |       |        |     |       |        |     |       |
| 193   |           | IMPELLER RING (DIL)                    | 4            | 1       |     | 1     |          | NA  |       | 2              |     | 3     |        | 4   |       |        |     |       |        |     |       |
| 220   |           | CASING COVER                           | 5            | 1       |     | 1     |          | 2   |       | 3              |     | 4     |        | 5   |       |        |     |       |        |     |       |
| 226   |           | DEP PAN                                | 1            | 1       |     | 1     |          | 1   |       | 1              |     | 1     |        | 1   |       |        |     |       |        |     |       |
| 227   |           | LANTERN RING                           | 1            | 1       |     | 1     |          | 1   |       | 1              |     | 1     |        | 1   |       |        |     |       |        |     |       |
| 229   |           | BRIT GLAND                             | 1            | 1       |     | 1     |          | 1   |       | 1              |     | 1     |        | 1   |       |        |     |       |        |     |       |
| 236   |           | LIQUID DEFLECTOR                       | 2            | 1       |     | 1     |          | 1   |       | 2              |     | 2     |        | 2   |       |        |     |       |        |     |       |
| 240   |           | BEARING HOUSING (STD.)                 | 2            | NA      |     | NA    |          | 1   |       | 2              |     | 2     |        | 2   |       |        |     |       |        |     |       |
| 252   |           | BEARING HOUSING (WITH COOLING)         | 2            | 1       |     | 1     |          | 1   |       | 2              |     | 2     |        | 2   |       |        |     |       |        |     |       |
| 248   |           | LANTERN BRACKET                        | 2            | 1       |     | 1     |          | 1   |       | 2              |     | 2     |        | 2   |       |        |     |       |        |     |       |
| 251   |           | SUPPORT FOOT FOR FOOT MOUNTED          | 4            | 1       |     | 1     |          | 2   |       | 3              |     | 3     |        | 4   |       |        |     |       |        |     |       |
| 251   |           | SUPPORT FOOT FOR CENTRE LINE MOUNTED   | 2            | 1       |     | 1     |          | 2   |       | 3              |     | 3     |        | 3   |       |        |     |       |        |     |       |
| 260.1,260.2   |           | DEP GROOVE BALL BEARING D.S. & P.S.    | NA           | NA      |     | NA    |          | NA  |       | NA             |     | NA    |        | NA  |       |        |     |       |        |     |       |
| 263   |           | ANGULAR CONTACT BALL BEARING           | 2            | 1       |     | 1     |          | 1   |       | 2              |     | 2     |        | 2   |       |        |     |       |        |     |       |
| 264   |           | CYLINDRICAL ROLLER BEARING             | 1            | 1       |     | 1     |          | 1   |       | 1              |     | 1     |        | 1   |       |        |     |       |        |     |       |
| 270   |           | BEARING COVER D.S.                     | 1            | 1       |     | 1     |          | 1   |       | 1              |     | 1     |        | 1   |       |        |     |       |        |     |       |
| 311   |           | SHAFT SLEEVE                           | 3            | 1       |     | 1     |          | 1   |       | 2              |     | 3     |        | 3   |       |        |     |       |        |     |       |
| 330   |           | IMPELLER NUT                           | 1            | 1       |     | 1     |          | 1   |       | 1              |     | 1     |        | 1   |       |        |     |       |        |     |       |
| 350   |           | ST. BOX BUSH                           | 2            | 1       |     | 1     |          | 1   |       | 1              |     | 2     |        | 2   |       |        |     |       |        |     |       |
| 387   |           | OIL WELL COVER FOR BRG/OIL COOLING     | 1            | 1       |     | 1     |          | 1   |       | 1              |     | 1     |        | 1   |       |        |     |       |        |     |       |
| 430   |           | GLAND PACKING                          | 1            | 1       |     | 1     |          | 1   |       | 1              |     | 1     |        | 1   |       |        |     |       |        |     |       |
| 440   |           | CONSTANT LEVEL GLER                    | 1            | 1       |     | 1     |          | 1   |       | 1              |     | 1     |        | 1   |       |        |     |       |        |     |       |
| 511   |           | BASKET FOR CASING COVER                | 4            | 1       |     | 1     |          | 2   |       | 3              |     | 3     |        | 4   |       |        |     |       |        |     |       |
| 514   |           | BASKET FOR BRG COVER D.S               | 1            | 1       |     | 1     |          | 1   |       | 1              |     | 1     |        | 1   |       |        |     |       |        |     |       |
| 515   |           | BASKET FOR SHAFT SLEEVE                | 1            | 1       |     | 1     |          | 2   |       | 2              |     | 2     |        | 2   |       |        |     |       |        |     |       |
| 525.1   |           | O-RING FOR CASING COVER                | 1            | 1       |     | 1     |          | 1   |       | 1              |     | 1     |        | 1   |       |        |     |       |        |     |       |
| 525.2   |           | O-RING FOR LANTERN BRACKET             | 1            | 1       |     | 1     |          | 1   |       | 1              |     | 1     |        | 1   |       |        |     |       |        |     |       |
| 882   |           | BASKET FOR IMPELLER NUT                | 2            | 1       |     | 1     |          | 1   |       | 2              |     | 2     |        | 2   |       |        |     |       |        |     |       |



| INTERCHANGEABILITY CHART OF KPD,KPD CLM, KPD-J PUMPS...(DRIVING UNIT NO. KPD - 12) |   |              |       |     |       |       |     |       |       |     |       |                         |     |       |        |     |       |        |     |       |         |     |       |         |     |       |
|--|---|--------------|-------|-----|-------|-------|-----|-------|-------|-----|-------|-------------------------|-----|-------|--------|-----|-------|--------|-----|-------|---------|-----|-------|---------|-----|-------|
| PART NO.   | PUMP SIZE                               | TOTAL NO. OF | 2000B |     |       | 2004B |     |       | 1946B |     |       | 125/30M<br>(2800 R.P.M) |     |       | 150/28 |     |       | 200/38 |     |       | 250/38A |     |       | 250/39B |     |       |
|  |   |              | FFD   | CLM | EPD/J | FFD   | CLM | EPD/J | FFD   | CLM | EPD/J | FFD                     | CLM | EPD/J | FFD    | CLM | EPD/J | FFD    | CLM | EPD/J | FFD     | CLM | EPD/J | FFD     | CLM | EPD/J |
|  |   |              |       |     |       |       |     |       |       |     |       |                         |     |       |        |     |       |        |     |       |         |     |       |         |     |       |
| 109  | PUMP CASING FOOT MOUNTED                | 10           | 1     | -   | 2     | 3     | -   | 4     | 5     | -   | 6     | 7                       | -   | 8     | 9      | -   | 10    | 11     | -   | 12    | 13      | -   | 14    | 15      | -   | 16    |
| 109  | PUMP CASING CENTRE LINE MOUNTED         | 8            | -     | 1   | -     | -     | 2   | -     | -     | 3   | -     | -                       | 4   | -     | -      | 5   | -     | -      | 6   | -     | -       | 7   | -     | -       | 8   | -     |
| 151  | ENCLOSED IMPELLER                       | 6            | 1     |     |       | 2     |     |       | 3     |     |       | 4                       |     |       | 5      |     |       | 6      |     |       | 7       |     |       | 8       |     |       |
| 153  | SEMI OPEN IMPELLER                      | NA           | NA    |     |       | NA    |     |       | NA    |     |       | NA                      |     |       | NA     |     |       | NA     |     |       | NA      |     |       | NA      |     |       |
| 162.1  | PUMP SHAFT WITH DEEP GROOVE BRG.        | 1            | 1     |     |       | 1     |     |       | 1     |     |       | 2                       |     |       | 1      |     |       | 1      |     |       | 1       |     |       | 1       |     |       |
| 162.2  | PUMP SHAFT WITH REINFORCED DRG. AIRSHT. | 1            | 1     |     |       | 1     |     |       | 1     |     |       | 2                       |     |       | 1      |     |       | 1      |     |       | 1       |     |       | 1       |     |       |
| 160  | CASING WEAR RING (SUCTION)              | 6            | 1     |     |       | 1     |     |       | 2     |     |       | 3                       |     |       | 4      |     |       | 5      |     |       | 6       |     |       | 6       |     |       |
| 161  | CASING WEAR RING (DEL.)                 | 5            | 1     |     |       | 1     |     |       | 2     |     |       | 3                       |     |       | NA     |     |       | 4      |     |       | 5       |     |       | 5       |     |       |
| 160  | IMPELLER WEAR RING (SUC.)               | 6            | 1     |     |       | 1     |     |       | 2     |     |       | 3                       |     |       | 4      |     |       | 5      |     |       | 6       |     |       | 6       |     |       |
| 160  | IMPELLER RING (DEL.)                    | 5            | 1     |     |       | 1     |     |       | 2     |     |       | 3                       |     |       | NA     |     |       | 4      |     |       | 5       |     |       | 5       |     |       |
| 200  | CASING COVER                            | 7            | 1     |     |       | 2     |     |       | 3     |     |       | 4                       |     |       | 5      |     |       | 6      |     |       | 7       |     |       | 7       |     |       |
| 226  | DEEP RING                               | 3            | 1     |     |       | 1     |     |       | 1     |     |       | 1                       |     |       | 2      |     |       | 3      |     |       | 3       |     |       | 3       |     |       |
| 227  | LANTERN RING                            | 2            | 1     |     |       | 1     |     |       | 1     |     |       | 2                       |     |       | 1      |     |       | 1      |     |       | 1       |     |       | 1       |     |       |
| 229  | ENT GUARD                               | 2            | 1     |     |       | 1     |     |       | 1     |     |       | 2                       |     |       | 1      |     |       | 1      |     |       | 1       |     |       | 1       |     |       |
| 208  | LIQUID DEFLECTOR                        | 3            | 1     |     |       | 1     |     |       | 2     |     |       | 3                       |     |       | 1      |     |       | 1      |     |       | 1       |     |       | 1       |     |       |
| 240  | BEARING HOUSING (STD.)                  | 1            | 1     |     |       | 1     |     |       | 1     |     |       | NA                      |     |       | 1      |     |       | 1      |     |       | 1       |     |       | 1       |     |       |
| 262  | BEARING HOUSING (WITH COOLING)          | 1            | 1     |     |       | 1     |     |       | 1     |     |       | 1                       |     |       | 1      |     |       | 1      |     |       | 1       |     |       | 1       |     |       |
| 246  | LANTERN BRACKET                         | 5            | 1     |     |       | 1     |     |       | 1     |     |       | 2                       |     |       | 3      |     |       | 4      |     |       | 5       |     |       | 5       |     |       |
| 261  | SUPPORT FOOT FOR FOOT MOUNTED           | 7            | 1     |     |       | 2     |     |       | 3     |     |       | 4                       |     |       | 5      |     |       | 6      |     |       | 7       |     |       | 7       |     |       |
| 261  | SUPPORT FOOT FOR CENTRE LINE MOUNTED    | 6            | 1     |     |       | 2     |     |       | 3     |     |       | 4                       |     |       | 5      |     |       | 6      |     |       | 7       |     |       | 6       |     |       |
| 280.1,280.2  | DEEP GROOVE BALL BEARING D.S. & P.S.    | NA           | NA    |     |       | NA    |     |       | NA    |     |       | NA                      |     |       | NA     |     |       | NA     |     |       | NA      |     |       | NA      |     |       |
| 263  | ANGULAR CONTACT BALL BEARING            | 1            | 1     |     |       | 1     |     |       | 1     |     |       | 1                       |     |       | 1      |     |       | 1      |     |       | 1       |     |       | 1       |     |       |
| 264  | CYLINDRICAL ROLLER BEARING              | 1            | 1     |     |       | 1     |     |       | 1     |     |       | 1                       |     |       | 1      |     |       | 1      |     |       | 1       |     |       | 1       |     |       |
| 270  | BEARING COVER D.S.                      | 1            | 1     |     |       | 1     |     |       | 1     |     |       | 1                       |     |       | 1      |     |       | 1      |     |       | 1       |     |       | 1       |     |       |
| 311  | SHAFT SLEEVE                            | 3            | 1     |     |       | 1     |     |       | 2     |     |       | 3                       |     |       | 1      |     |       | 1      |     |       | 1       |     |       | 1       |     |       |
| 300  | IMPELLER NUT                            | 2            | 1     |     |       | 1     |     |       | 1     |     |       | 2                       |     |       | 1      |     |       | 1      |     |       | 1       |     |       | 1       |     |       |
| 360  | ST. BOX WRENCH                          | 2            | 1     |     |       | 1     |     |       | 1     |     |       | 2                       |     |       | 1      |     |       | 1      |     |       | 1       |     |       | 1       |     |       |
| 367  | OIL WELL COVER FOR BRG.OIL COOLING      | 1            | 1     |     |       | 1     |     |       | 1     |     |       | 1                       |     |       | 1      |     |       | 1      |     |       | 1       |     |       | 1       |     |       |
| 400  | GLAND PACKING                           | 2            | 1     |     |       | 1     |     |       | 1     |     |       | 2                       |     |       | 1      |     |       | 1      |     |       | 1       |     |       | 1       |     |       |
| 443  | CONSTANT LEVEL GLASS                    | 1            | 1     |     |       | 1     |     |       | 1     |     |       | 1                       |     |       | 1      |     |       | 1      |     |       | 1       |     |       | 1       |     |       |
| 460  | WEAR PLATE SUC. SIDE                    | NA           | NA    |     |       | NA    |     |       | NA    |     |       | NA                      |     |       | NA     |     |       | NA     |     |       | NA      |     |       | NA      |     |       |
| 511  | BAKSET FOR CASING COVER                 | 7            | 1     |     |       | 2     |     |       | 3     |     |       | 4                       |     |       | 5      |     |       | 6      |     |       | 7       |     |       | 7       |     |       |
| 514  | BAKSET FOR BRG.COVER D.S                | 1            | 1     |     |       | 1     |     |       | 1     |     |       | 1                       |     |       | 1      |     |       | 1      |     |       | 1       |     |       | 1       |     |       |
| 515  | BAKSET FOR SHAFT SLEEVE                 | 3            | 1     |     |       | 1     |     |       | 1     |     |       | 2                       |     |       | 1      |     |       | 1      |     |       | 1       |     |       | 1       |     |       |
| 525.1  | TO RING FOR CASING COVER                | 2            | 1     |     |       | 1     |     |       | 1     |     |       | 2                       |     |       | 1      |     |       | 1      |     |       | 1       |     |       | 1       |     |       |
| 525.2  | OY RING FOR LANTERN BRACKET             | 3            | 1     |     |       | 1     |     |       | 1     |     |       | 2                       |     |       | 3      |     |       | 1      |     |       | 1       |     |       | 1       |     |       |
| 660  | BAKSET FOR IMPELLER NUT                 | 1            | 1     |     |       | 1     |     |       | 1     |     |       | 1                       |     |       | 1      |     |       | 1      |     |       | 1       |     |       | 1       |     |       |



Enriching Lives

# **KIRLOSKAR PUMP TYPE – KPDQF (DRIVING UNIT – 4)**

## **1.0 KPD – 4 PUMPS – TAPPING CONNECTIONS CHART**

(See separate chart)

## **2.0 TECHNICAL DATA**

### **2.1 Direction of rotation:**

The direction of rotation is clockwise when viewed from driving end.

### **2.2 Specifications of oil seal and quantity of oil**



| Part No. | Description   | size  | Remark     |
|----------|---|---|------------|
| 50001    | Oil seal D.S.<br><br>Quantity of oil in bearing housing (Approx.) | Unit no.4<br>18X 35 X7 thick<br><br>0.1 liter | Std supply |

### 2.3 Bearing:

- Bearings of SKF make or equivalent and with C3 clearance are used. Bearings are oil lubricated. Oil level in the bearing housing should be maintained with the help of constant level oiler. Constant level oiler is a standard scope of supply.
- Maximum allowable temperature of bearings: 80°C
- In case of pumping liquids above 180° C, cooling of lubricant oil shall be necessary. Bearing housing cooling arrangement provided, quantity of cooling water required is 0.25 m<sup>3</sup>/hr at 6 kg/cm<sup>2</sup>.
- In case of new bearings, renew the oil after about 200 hours and then about once a year, if the bearing temperature is always below 50°C and there is only small risk of contamination. If the bearing temperature is upto 80°C and if there is danger of contamination, the oil should be renewed about every six months.

| Driving unit | Speed n rpm | Bearing arrangement | Bearing at DE  | Bearing at NDE    | Remarks         |
|--------------|-------------|---------------------|--|-------------------|-----------------|
| 4            | 3000        | Standard            | SKF 6304 C3 or equi. 1 No. and SKF 7304 B or equi. 1 No. | SKF 6304 C3 1 No. | Standard supply |

#### Note:

- Above bearing arrangement is suitable for a pump operating on suction pressure is less than 5 kg/cm<sup>2</sup>.
- Applications involving suction pressure more than 5 kg/cm<sup>2</sup> should be referred to head office at Pune.
- Axial running clearance shall be less than 0.45 mm for the above bearing arrangement.
- Bearing should be lubricated with lubricating oil as indicated below:

| Manufacturer                      | Speed 1450 rpm             | Speed 2900 rpm             |
|-----------------------------------|----------------------------|----------------------------|
| Indian oil<br>Hindustan Petroleum | Servosystem 81<br>Enklo 57 | Servosystem 57<br>Enklo 53 |

### 2.4 Specification for stuffing box packing, gaskets, & 'O' rings for KPD-4 pumps.



| Part  | Description  | KPD 20/13 QF           | KPD 20/16 QF             | KPD 20/20 QF           |
|-------|--|------------------------|--------------------------|------------------------|
|       | Packing arrangement with Lantern ring                      | 2 + L + 3              | 2 + L + 3                | 2 + L + 3              |
| 43000 | Gland packing size(ODxIDxT) straight length of one packing | 44x28x8<br>115 mm      | 44x28x8<br>115 mm        | 44x28x8<br>115 mm      |
| 51100 | Gasket for casing & casing cover (ODxIDxT)                 | 152 OD x141 IDx1 Thick | 188 OD x176 ID x 1 Thick | 230 Odx216 ID x1 Thick |
| 51400 | Gasket for bearing cover (ODxIDxT)                         | 85 OD x52 IDx1 Thick   | 85 OD x52 IDx1 Thick     | 85 OD x52 IDx1 Thick   |
| 51600 | Gasket for Mech. Seal cover (ODxIDxT)                      | 60 OD x50 ldx2 Thick   | 60 OD x50 ldx2 Thick     | 60 OD x50 ldx2 Thick   |
| 87500 | Gasket for oil well cover (ODxIDxT)                        | 128x85x1.5 T           | 128x85x1.5 T             | 128x85x1.5 T           |
| 57500 | Gasket for impeller & shaft sleeve                         | 230 OD x17 ldx1 Thick  | 230 OD x17 ldx1 Thick    | 230 OD x17 ldx1 Thick  |
| 52510 | 'O' ring for casing cover                                  | 96 ID x3 T             | 96 ID x3 T               | 96 ID x3 T             |
| 52310 | 'O' ring for bearing housing                               | 142 ID x3T             | 142 ID x3T               | 142 ID x3T             |
| 52300 | 'O' ring for bearing cartridge                             | 60 ID x3T              | 60 ID x3T                | 60 ID x3T              |

**Note:**

1. Correct liquid specification should be informed to us to recommend a suitable grade of gland packing.
2. All dimensions are in mm.

## 2.5 Cooling of stuffing box, bearing housing and pump pads.

2.5.1 Cool the packed stuffing box when pumping liquid temperature is above 105° C.

2.5.2 Cool the mechanical seal, stuffing box when pumping liquid temperature is above 140° C. this limit is subject to change as per seal manufacturer's recommendations.

2.5.3 Quantity of stuffing box cooling water w. r. t. temperature and nominal impeller diameter in cms.

| Full nominal dia. in | Cooling water quantity at various pumping liquid temperature |        |        |        |        |
|----------------------|--|--------|--------|--------|--------|
|                      | 110° C   | 150° C | 200° C | 250° C | 300° C |
| cms.                 |  |        |        |        |        |
| 13                   | 0.16   | 0.18   | 0.24   | 0.31   | 0.43   |
| 16                   | 0.16   | 0.18   | 0.24   | 0.31   | 0.43   |
| 20                   | 0.16   | 0.18   | 0.24   | 0.31   | 0.43   |

Cooling water quantities mentioned in m<sup>3</sup> /hour.





Maximum temperature of cooling water at outlet -50° C.  
Maximum permissible cooling water pressure- 6.0 kg/cm<sup>2</sup>.

2.5.4 Cooling of pump pads

Centerline mounted pumps are supported on pads through which cooling water should be circulated. Centerline mounted pumps are recommended for pumping liquid temperature above 180° C. pump with centerline mounted delivery casing is optional.

Quantity of cooling water to pad – 0.2 to 0.3 m<sup>3</sup> /hour.

Maximum pressure - 6 kg/cm<sup>2</sup>.

2.6 Clearance between impeller vanes and wear face on pump casing suction side should be 0.3 to 0.5 mm.

2.7 Interchangeability

Parts standardization is optimized utilizing interchangeable components to cover a very wide range of requirement. This unique feature enables the customer to have a very low spare parts inventory even though he may have many sizes of these pumps. Interchangeability chart is given in 2.7.1

**3.0 Maintenance :**

Preventive maintenance schedule is the periodical check and precautions by which possibilities of failure and breakdowns are minimized.

3.1 Daily checks:

Same as that for other KPD pumps. (i.e. Repeat 5.3.1.1 to 5.3.1.3 of KPD data)

3.2 Periodical checks:

Same as that for other KPD pumps. (i.e. repeat 5.3.2.1 to 5.3.2.6)

3.3 Annual checks :

3.3.1 The pump should be over hauled completely to check the clearance and to replace worn out parts. Clearance between impeller vanes and pump casing wear face, shaft sleeve and stuffing box bush, lantern ring and shaft sleeve etc. are very important. The bearing should be cleaned thoroughly and lubricated. The stuffing box should be repacked by correctly locating the lantern ring. Other check points are same as that of KPD pumps.

**4.0 MECHANICAL SEAL IN KPD –4 PUMPS**

Same as that for other KPD pumps. ( i.e. refer 5.3.4)

**5.0 OVERHAULING**

**PROCEDURE FOR DISMANTLING AND RE-ASSEMBLING**

While dismantling and re assembling, the cross-sectional assembly drawing and list should be referred.

5.1 Dismantling:

5.1.1 to 5.1.9 Same as that for other KPD pumps. (Repeat 5.2.1.1.1 to 5.2.1.1.9)



- 5.1.10 Remove the hex nuts from casing studs holding the bearing housing (24000) in case of KPD 20/13 QF pump. Remove the hex nuts from casing studs holding the casing cover (22000) in case of KPD 20/16 QF and KPD 20/20 QF pumps.
- 5.1.11 Screw the release bolts provided in the casing cover. Turn the bolts evenly through a quarter turn at both sides.
- 5.1.12 Slightly pull out the driving unit, till impeller (15300) clears the pump casing (10500/10600).
- 5.1.13 Place this rotating unit on a table or clear place for further dismantling.
- 5.1.14 Remove casing gasket (51101).
- 5.1.15 Unscrew the impeller (15300). Remove the gasket between impeller and shaft sleeve (51500) after taking out the impeller from pump shaft (18000).
- 5.1.16 Removal of stuffing box with gland packing:  
For this, following steps should be taken:
  - a. Remove the split gland (22900) by taking out the bolts for clamping of the split positions.
  - b. Take out the casing cover (22000) along with stuffing box bush (35000), gland packing (43000), and lantern ring (22700), 'O' ring (52501) will also come out along with it.
  - c. Take out 'O' ring (52502) for bearing housing.
  - d. Unscrew the hex socketted screw clamping stuffing box bush (35000) to casing cover (22000) and remove the stuffing box bush (35000).
  - e. Remove gland packing rings (43000) and lantern ring (22700).
  - f. Remove shaft sleeve (31100) and key(32000) along with liquid deflector (23600).
- 5.1.17 Removal of stuffing box with mechanical seal.  
(Applicable for single and double mechanical seals). Follow the steps given below:
  - a. Unscrew the hex socketted cap screw clamping the stuffing box bush (35000) to the casing cover (22000) and remove the stuffing box bush.
  - b. Seal seat will come out along with the throat bush (35000) in case of double mechanical seal.
  - c. Pull shaft sleeve under mechanical seal (31500). Use the groove on the shaft sleeve for pulling it out. Be careful while removing shaft sleeve since sleeve comes out alongwith rotating unit of the mechanical seal.
  - d. Remove the mechanical seal from the shaft sleeve and keep it in a clean place.
  - e. Remove hex nuts from casing cover (22000) studs, for 20/16 QF and 20/20 QF pumps. For 20/13 QF pump no necessity of studs is there because the casing cover is of sandwich type.
  - f. Take out the casing cover (22000) along with the mechanical seal cover taking care of mating ring face. 'O' ring for casing cover (52501) will also come out along with it.
  - g. Unscrew the nuts of mechanical seal cover studs and remove mechanical seal cover studs and remove mechanical seal covers (23100) from casing cover (22000).



- h. In case of externally mounted mechanical seals, similar procedure should be followed only with the change that casing cover (22000) should be removed before removing shaft sleeve (31500) along with mechanical seal.
- 5.1.18 Loosen the grub screw holding the liquid deflector (23601). Take out the liquid deflector.
- 5.1.19 Take out "O" ring for bearing housing (52502) carefully.
- 5.1.20 Remove the pump half coupling (39700) carefully, after unscrewing the grub screw.

**Caution**

Coupling half should be removed with the help of suitable extraction device. To avoid damage to the bearings, the coupling half should not be knocked off the shaft.

- 5.1.21 Take out the coupling key (32100).
- 5.1.22 Loosen the hex screws for bearing cover (NDE) (27100). Remove carefully the bearing cover (27100) and packing (51400).
- 5.1.23 Loosen the nuts (58600) from bearing housing studs (59300) receiving bearing cartridge (24100).
- 5.1.24 Force the shaft (18020) out carefully in the direction of the driving end. Shaft will come out with bearings and bearing cartridge (24100).
- 5.1.25 Remove circlip (48500), remove the bearing cartridge (24100) with the help of a suitable puller.
- 5.1.26 Unlock the washer (41500) and remove lock nut (33600).
- 5.1.27 Take out the driving end groove ball bearing (26000) with the help of puller.
- 5.1.28 Take out spacer ring (20900) between the DE bearings.
- 5.1.29 Take out driving end angular contact ball bearing (26300) with the help puller.
- 5.1.30 Take out shoulder ring (19900) for driving end bearings.
- 5.1.31 Take out the non-driving end ball bearing (26000) with the help of a suitable puller.
- 5.1.32 Take out the non-driving end shoulder ring (19900).

**Caution**

Steps 5.1.24 to 5.1.30 are to be followed only if bearings are damaged and to be replaced.

- 5.1.33 Oil seal in the bearing cartridge (50010) should be removed if the seal lips are worn out or spring has lost tension.
- 5.1.34 Remove the 'O' ring for bearing cartridge (52310) from it. For pumps with bearing cooling arrangement, following steps should be followed to dismantle the cooling arrangement.
- 5.1.35 Take out cover for bearing housing cooling arrangement (36700).
- 5.1.36 Take out the packing (68500).

**5.2 REASSEMBLY**



This procedure covers re-assembly of pump after complete dismantling of the pump. Before re-assembly, all the parts should be thoroughly cleaned in kerosene, petrol or benzene to remove the dust, rust etc. After cleaning the necessary parts should be replaced.

- 5.2.1 Mount the shoulder ring (19900), angular contact ball bearing (26300), spacer ring (20900) and deep groove ball bearing (26000) at the driving end in the order stated above. (Refer fig. For Brg. arrangement).
- 5.2.2 Mount the non-driving end deep groove ball bearing (26000).

### **Caution**

Same as given under 5.2.1.2.1 of KPD pump manual.

- 5.2.3 Same clause as that of 5.2.1.2.3 of KPD pump manual except the sentence in bracket.
- 5.2.4 Fit the oil seal (50010) in the bearing cartridge (24100) and 'O' ring (52300) on the cartridge.
- 5.2.5 Insert the circlip (48500) in the groove provided for it.
- 5.2.6 Insert shaft (18000) along with bearings and cartridge into the bearing housing from driving end and tighten the hex. nut for studs on bearing housing for bearing cartridge till the gap between cartridge and housing is 3 mm.
- 5.2.7 Put the packing (54000) at non - driving end and tighten the bearing cover (271) with the help of hex. screws.
- 5.2.8 Place 'O' ring (52510) on bearing housing. Lubricate the ring with grease or other suitable 'O' ring lubricant before placing it on the bearing housing.
- 5.2.9 Put the drip pan (22600) (if applicable) & if it was removed from bearing housing.
- 5.2.10 For pumps with gland packing arrangements, follow the instructions given below.
  - a) Apply some oil or grease on the shaft at sleeve position. Mount the key for shaft sleeve (32000) on shaft and insert shaft sleeve (31100) along with deflector (23600) mounted on it.
  - b) Place 'O' ring (52510) on casing cover after lubricating it properly for Hot Models only.
  - c) Insert casing cover (22000) with 'O' ring (51510) and drip plate (21900) in proper positions.
  - d) Tighten the nuts on studs of casing cover in case of pump types KPD 20/16 QF and KPD20/20 QF. For KPD 20/13 QF pump, casing cover (22000) is guided on bearing housing (24000) steps.
  - e) Fit stuffing box bush (35000) into the casing cover and tighten the hex. socketted screws.
  - f) Put the gasket for shaft sleeve and impeller (51500) on shaft sleeve (31100) step.
  - g) Fix the impeller on the shaft with heli-coil-mid-grip insert by screwing it on the shaft. Refer to figure for impeller fixing arrangement and heli-coil-mid-grip insert.
  - h) Tighten the grub screws on the labyrinth type deflector.



- 5.2.11 For pumps with mechanical seal arrangement, follow the instructions given below. (Applicable for internally fitted seals only).
- a) Mount the deflector (23610) on shaft.
  - b) Replace the bush for mechanical seal cover (36000) (Throttle bush) if it is worn out.
  - c) Place the mechanical seal cover (23100) along with stationary seal seat/insert/mating ring and gasket (51600) and tighten the nuts on studs for mechanical seal cover on casing cover evenly.
  - d) Remove location plates with the help of Allen screws.
  - e) Place 'O' ring (52501) on casing cover (22000) after lubricating it properly.
  - f) Insert the casing cover (22000) with 'O' rings (52501 and 52502) in proper positions, in brg. housing. Tighten the nuts on the studs of casing cover in case of KPD 20/16 QF and KPD 20/20 QF pumps. For KPD 20/13 QF pump, guide the casing cover on the steps of bearing housing.
  - g) Mount rotating part of mechanical seal on shaft sleeve (31500) after applying oil on it.
  - h) Tighten grub screws provided in rotating element of mechanical seal after resting seal against step on sleeve.
  - i) Mount shaft sleeve key (32000) on shaft and push the sleeve (31500) along with mechanical seal with care till the face of rotating part touches the stationary seal/seat/insert/mating ring.
  - j) Fit stuffing box bush (35000) into casing cover. In case of double mechanical seal fit mechanical seal seat/insert mating ring of seal towards impeller end in stuffing box bush (35000) and then fit it in casing cover. Tighten the hex. socketed grub screws.
  - k) Put gasket (51500) on shaft sleeve step in proper position.
  - l) Fix the impeller on the shaft along with the helicoil mid-grip insert avg. gradually tighten it.
  - m) Tighten the grub screw on the labyrinth deflector (23610) after resting its shoulder against shaft sleeve shoulder.

This will complete back pull out assembly.

For the external mechanical seals, follow similar assembling procedure with following changes.

- a. Insert shaft sleeve into shaft before fitting casing cover (22000) on to the bearing housing (24000).
- b. Rotating part of the mechanical sleeve should be mounted on the shaft sleeve (31500) such that working length of the mechanical seal given on cross sectional drawing supplied to you against particular pump is maintained.

For re-assembly of the bearing housing cooling arrangement, follow steps below:

- a. Fit the cover for bearing housing cooling arrangement (36700) with packing (68500) and tighten the screws.

## 5.2.12 Rotating unit - General assembly procedure for pumps



- a) Slide complete, back pull out assembly into pump casing. (10500/10600)
- b) Tighten all the nuts on casing studs firmly and evenly.

### **Caution**

The clearance between the wear face on pump casing suction side and impeller vanes is recommended to be 0.3 to 0.5 mm. Hydraulic performance of pump depends upon this clearance. If clearance is more, Head-Capacity of pump drops down. Hence the clearance should be adjusted by using the telescopic shaft arrangement. The procedure is mentioned below:

- a) The clearance between the bearing cartridge (24100) and bearing housing (24000) face at driving end, is 3 mm in normal condition. So while reassembling the back-pull out assembly, keep the hex screws (63500) in loose condition and tighten the casing cover to the screws (63500) in loose condition and tighten the casing cover to the casing for KPD 20/16 QF and KPD 20/20 QF pumps.

For KPD 20/13 QF pump, tighten the bearing housing to the casing keeping hex screws (63500) for bearing housing in loose condition.

- b) Tighten the axial gap bearing cartridge (58600) so that the impeller just touches pump casing wear face.
- c) Measure the hex nuts for bearing cartridge (24100) and bearing housing (24000) faces at driving end.
- d) Normally, when the impeller touches the wear face, this gap should be 2.5 mm as the clearance between the impeller and wear face is 0.5 mm. Therefore if the casing or impeller and is worn, then it is necessary to adjust the clearance between the impeller and casing wear face to 0.5 mm. For this, loosen the bearing cartridge nuts (58600) and tighten the hex screws for bearing cartridge (63500) to create the necessary clearance between the casing wear face and impeller. This can be checked by rotating the shaft by hand. The hex screws should be tightened evenly till the shaft rotates freely.
- e) Tighten the bearing cartridge nuts (58600) to maintain the shaft position.
- f) For mechanical shaft fitted pumps, more care is required to be taken. It is required to adjust the spring compression between the stationary mating ring and rotary seal ring as it is disturbed and lessened of shaft movement.

For this, following procedure should be followed-

- ii) Loosen the back-pull-out assembly from pump casing. Remove it.
- iii) Remove the impeller (15300) from the shaft(18020)
- iv) Remove stuffing box bush (35000) from casing cover (22000).
- v) Remove the shaft sleeve with rotary unit of the mechanical seal.
- vi) Loosen the grub screws of rotary unit and retighten the unit at a distance of 1.0 mm towards driving end side of the shaft sleeve from its original position.
- vii) Fit the shaft sleeve along with the mechanical seal rotary unit.
- viii) Fit the stuffing box bush (35000).
- ix) Fit the impeller (15300) on the shaft.
- x) Tighten the back-pull-out assembly to the pump casing by tightening casing nuts (58100).



- 5.2.13 In case of pump with gland packing, insert gland packing (43000) and lantern ring (22700) in order of 2 rings first and then lantern ring and finally 3 rings. Joints should be staggered.
- 5.2.14 Put gland in two halves (22900), clamp them with gland bolts (57400). Tighten gland stud nuts.
- 5.2.15 Fit constant level oiler (44300), Breather cap (44400) & support foot (25100) to bearing housing.
- 5.2.16 Fit pump half coupling (39700).
- 5.2.17 Rotate shaft by hand and ensure free rotation.
- 5.2.18 Fit all accessories such as sealing water, flushing water, cooling water connection, hot water/ steam circulation etc.
- 5.2.19 Fit support foot (25100) to bearing housing.
- 5.2.20 Fit coupling spacer between pump half and motor half coupling in case of spacer type flexible couplings.
- 5.2.21 Mount motor on the base in case of standard flexible coupling and align the unit.
- 5.2.22 Fit coupling guard.

1. KPD 20/13QF



Enriching Lives

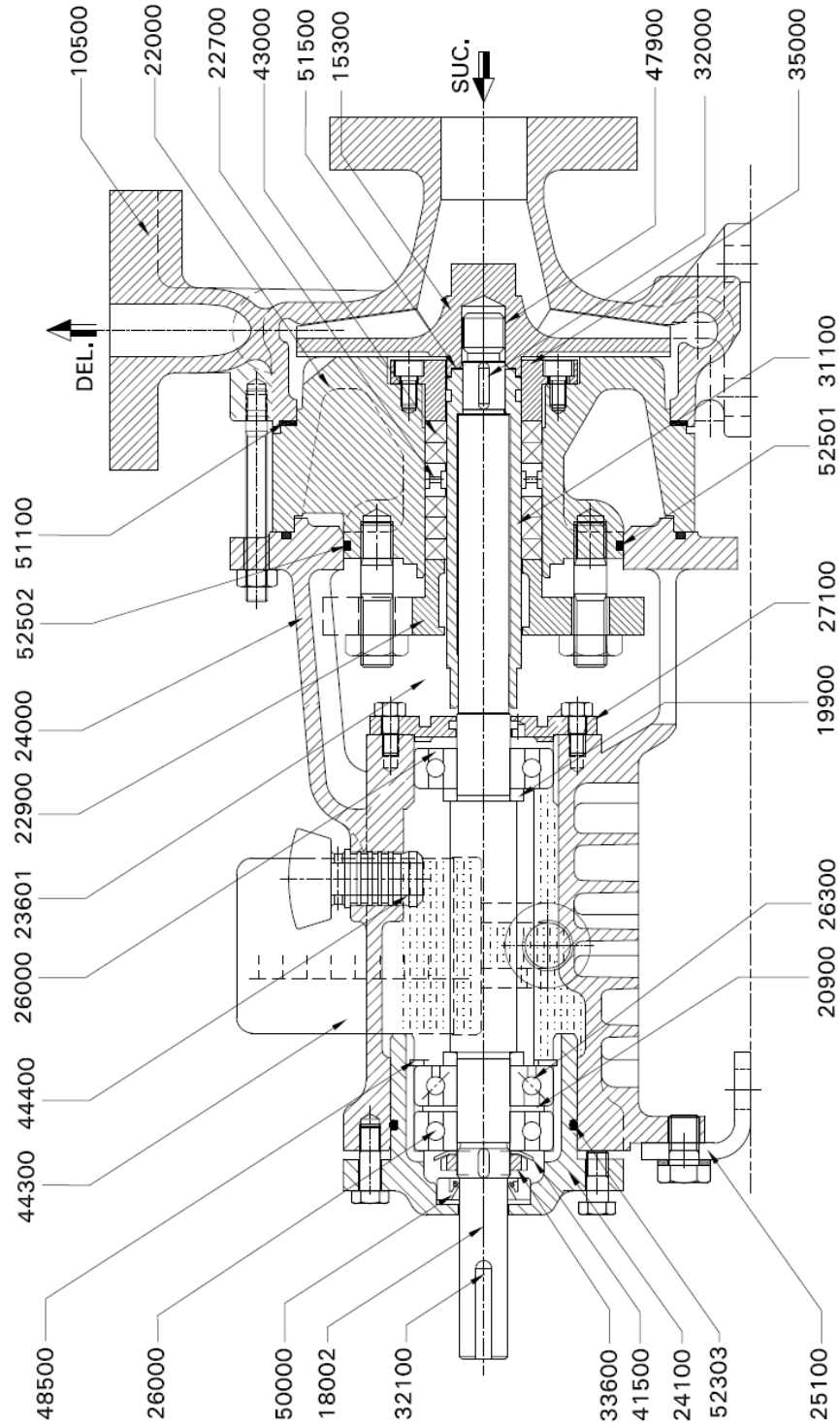

## 2. KPD 20/16, 20/20QF





Enriching Lives

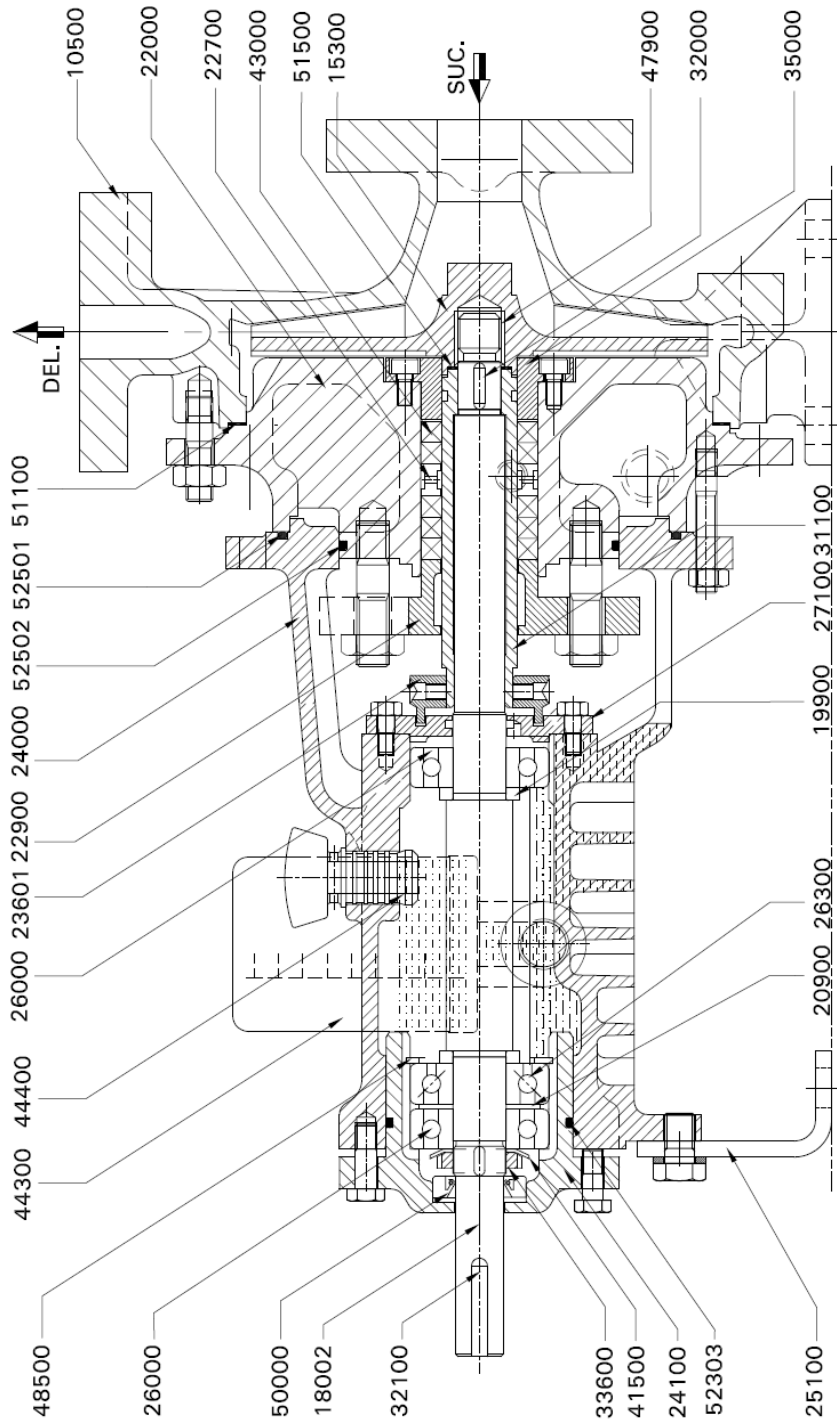



# Partial assembly of telescopic arrangement

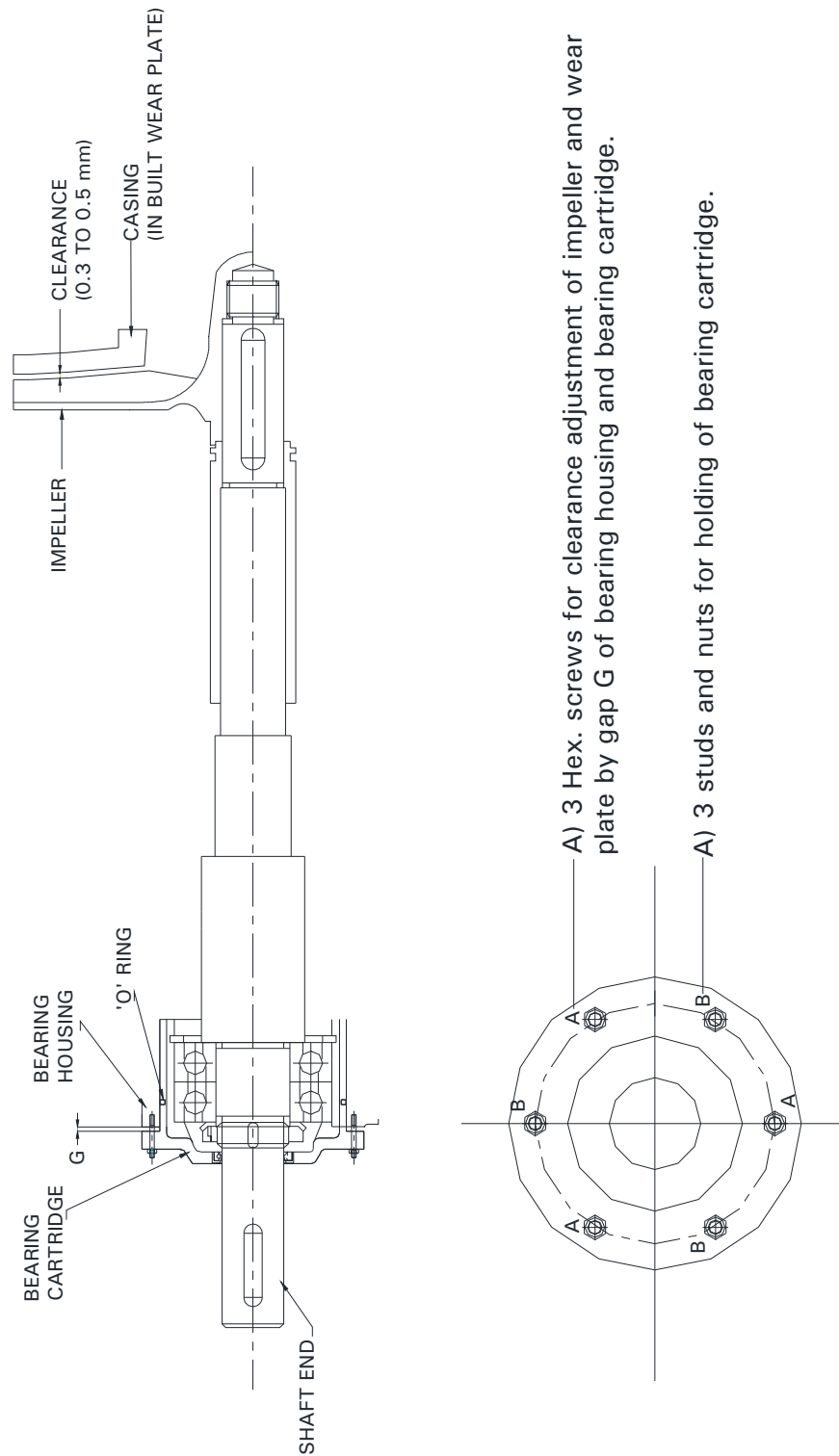

## GENERAL INFORMATION & SAFETY INSTRUCTIONS

View from shaft end of bearing cartridge.



- 1.0 The products supplied by KBL have been designed with safety in mind. Where hazards cannot be eliminated, the risk has been minimized by the use of guards and other design features. Some hazards cannot be guarded against and the instructions below **MUST BE COMPLIED WITH** for safe operation. These instructions cannot cover all circumstances. Installation, operation and maintenance personnel must use safe working practices at all the times.
- 1.1 KBL products are designed for installation in designated areas, which are to be kept clean and free of obstructions that may restrict safe access to the controls and maintenance access points.  
A pump duty nameplate is fitted to each unit and must not be removed. Loss of this plate could make identification impossible. This in turn could affect safety and cause difficulty in obtaining spare parts. If accidental loss or damage occurs, contact KBL immediately.
- 1.2 Access to the equipment should be restricted to the person net responsible for installation, operation and maintenance and they must be trained, adequately qualified and supplied with appropriate tools for their respective tasks.
- 1.3 Most accidents involving product operation, maintenance and repair are caused by failure to observe safety rules or precautions. An accident can often be avoided by recognizing potentially situations before an accident occurs. A person must be aware of potential hazard associated in activities of installation, operation and maintenance of equipments.
- 1.4 KBL requires that, all personnel that are responsible for installation, operation or maintenance of the equipment, have access to and study the product instruction manual **BEFORE** any work is done and that they will comply with all local and industry based safety instructions and regulations.
- 1.5 Ear defenders should be worn where the specified equipment noise level exceeds locally defined safe levels. Safety glasses or goggles or face



shield should be worn where working with pressurized systems and hazardous substances. Other personal protection equipment must be worn where local rules apply. Wear safety shoes, helmets and cotton overall [Apron] when you enter pump house. Noise level should not exceed 90 dbA and 110 dbA for motor driven and engine driven pumps, respectively.

- 1.6 Do not wear loose clothing or jewelry, which could catch on the controls or become trapped in the equipment.
- 1.7 Read the instruction manual before installation, operation or maintenance of the equipment. Check and confirm that you are referring relevant copy of the manual by comparing pump type on the nameplate and with that on the manual.
- 1.8 Note the "Limits of product application permissible use" specified in the manual. Operation of the equipment beyond these limits will increase the risk from hazards noted below and may lead to premature and hazardous pump failure.
- 1.9 Clear and easy access to all controls, gauges and dials etc must be maintained at all times. Hazardous or flammable materials must not be stored in pump rooms unless safe areas or racking and suitable container have been provided.
- 1.10 Use suitable earthing and tripping devices for electrical equipments.

**2. IMPROPER INSTALLATION, OPERATION, MAINTENANCE, LUBRICATION, REPAIR OF THIS KBL PRODUCT COULD RESULT IN INJURY OR DEATH.**

If any tool, procedure, work method and operation technique is not recommended by KIRLOSKAR BROTHERS LIMITED is used or followed, it



should be ensured that it is a safe for personnel around and others. It should also be ensured that the product will not be damaged or made unsafe by the operation, lubrication and maintenance or repair procedures you choose.

### **3. SAFETY INSTRUCTIONS WHILE HANDLING AND STORAGE**

When lifting the pump, use the lifting points specified on general arrangement drawing, if provided. Use lifting equipment having a safe working load rating suitable for the weight specified. Use suitable slings for lifting pump, which is not provided, with lifting points. The use of forklift truck and chain crane sling equipment is recommended but locally approved equipment of suitable rating may be used. While lifting, the equipment adjusts the center of gravity, so that it is balanced properly.

Do not place fingers or hands etc into the suction or discharge pipe outlets and do not touch the impeller, if rotated this may cause severe injury. To prevent ingress of any objects, retain the protection covers or packaging in place until removal is necessary for installation. If the packaging or suction and discharge covers are removed for inspection purposes, replace afterwards to protect the pump and maintain safety.

### **4. SAFETY INSTRUCTIONS WHILE ASSEMBLY & INSTALLATION**

Shaft alignment must be checked again after the final positioning of the pump unit and connection to pipework as this may have disturbed the pump or motor mounting positions. If hot liquids [above 80°C] are being pumped, alignment should be checked and reset with the pump and motor at their normal operating temperature. If this is not possible, KBL can supply estimated initial offset figures to suit extreme operating temperatures.

Failure to support suction and delivery pipework may result in distortion of the pump casing, with the possibility of early pump failure.

### **5. SAFETY INSTRUCTIONS WHILE COMMISSIONING & OPERATION**



Never attempt adjustments while the pump is running, unless otherwise specified in the operation, maintenance manual.

Do not touch any moving or rotating parts. Guards are provided to prevent access to these parts, where they have been removed for maintenance they must be replaced before operating the equipment.

Check that pump is primed. Pump should never be run dry as the pumped liquid acts as lubricant for the close running fits surrounding impeller and damage will be incurred.

Failure to supply the stuffing box or mechanical seal with cooling of flush water may result in damage and premature failure of the pump.

Do not touch surfaces, which during normal running will be sufficiently hot to cause injury. Note that these surfaces remain hot after the pump has stopped, allow sufficient time for cooling before maintenance. Be cautious and note that other parts of the pump may become hot if a fault is developing.

Do not operate water pumps in temperatures below freezing point, without first checking that the pumped fluid is not frozen and the pump is free to turn. Pumps in these environments should be drained down during inactivity and re-primed before starting.

In addition to local or site regulations for noise protection, KBL recommend the use of personal ear protection equipment in all enclosed pump rooms and particularly those containing diesel engines. Care must be taken to ensure that any audible alarm or warning signal can be heard with ear defenders worn.

Be aware of the hazards relating to the pump fluid, especially the danger from inhalation of noxious and toxic gases, skin and eye contact or penetration. Obtain and understand the hazardous substance data sheets



relating to the pumped fluid and note the recommended emergency and first aid procedures.

## **6. SAFETY INSTRUCTIONS WHILE MAINTENANCE & SERVICING**

Do not attempt repairs of the pump or its accessories which you do not know. Use proper tools.

Before attempting any maintenance on a pump particularly if it has been handling any form of hazardous liquid, it should be ensured that the unit is safe to work on. The pump must be flushed thoroughly with suitable cleaner to purge away any of the product left in the pump components.

This should be carried out by the plant operator and a certificate of cleanliness obtained before starting work. To avoid any risk to health it is also advisable to wear protective clothing as recommended by the site safety officer especially when removing old packing, which may be contaminated.

Isolate the equipment before any maintenance work is done. Switch off the main supply, remove fuses, apply lockouts where applicable and affix suitable isolation warning signs to prevent inadvertent reconnection. In order to avoid the possibility of maintenance personnel inhaling dangerous fumes or vapours locations by removal of bearing housing and shaft assembly to a suitable maintenance area.

Check and ensure that the pump operates at below the maximum working pressure specified in the manual or on the pump nameplate and before maintenance, ensure that the pump is drained down.

Wear a suitable mask or respirator when working with packing and gasket contain fibrous material, as these can be hazardous when the fibrous dust is inhaled. Be cautious, if other supplier's components have been substituted for genuine KBL parts, these may then contain hazardous materials.

Store all oily rags or other flammable material in a protective container in a safe place. Do not weld or flame cut on pipes/tubes that contents flammable



Enriching Lives

fluids. Clean them thoroughly with nonflammable solvent before welding or flame cutting on them. Use solvent/chemical resistant gloves for hand protection.

**Dispose of all wastes like gaskets, gland packing, oil, batteries, packing material etc in accordance with local regulations. Normally this would involve incineration of liquid waste and controlled landfill of polymerized material.**

Adequacy of suitable crane should be checked before lifting the pump/pump components. Also condition of pulleys, chain and lifting shackles should be checked before use.





# GENERAL INSTRUCTIONS FOR INSTALLATION, OPERATION & MAINTENANCE OF KIRLOSKAR CENTRIFUGAL PUMPS

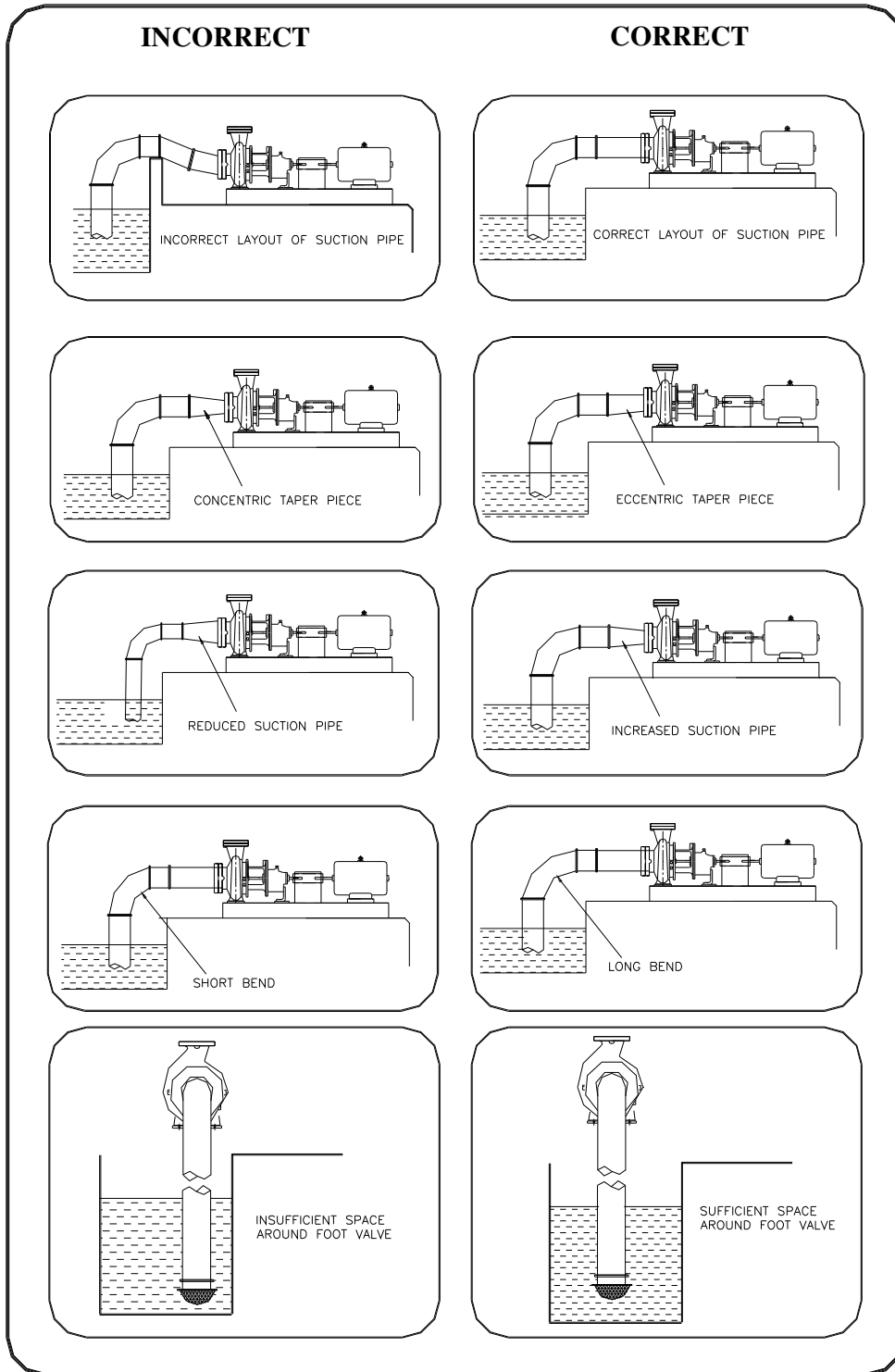

# GENERAL INSTRUCTIONS FOR INSTALLATION, OPERATION & MAINTENANCE OF



## **KIRLOSKAR CENTRIFUGAL PUMPS**

### **WARNING**

The equipment supplied is designed for specific capacity, speed pressure and temperature. Do not use the equipment beyond the capacities for which it is manufactured. The equipment manufactured is also shop tested for satisfactory performance and if it is operated in excess of the conditions for which it is manufactured, the equipment is subjected to excessive stresses and strains.

### **LOCATION**

The pump should be located as near the liquid source as possible. This will minimize suction lift and pump will give better performance.

Ample space should be provided on all the sides so that the pump can be inspected while in operation and can be serviced whenever required.

### **FOUNDATION**

The foundation should be sufficiently substantial to sustain any vibrations and to form a permanent rigid support for the base plate. This is important in maintaining the alignment of a directly connected unit. A concrete foundation on a solid base is advisable. Foundation bolts of the proper size should be embedded in the concrete located by a drawing or template. A pipe sleeve of two and one half diameter larger than the bolt should be used to allow movement for the final position of the foundation bolts. Earthing is required to be provided to the base plate.

### **ALIGNMENT**

Pumps and the drivers supplied by the manufacturers, mounted on a common base plate are accurately aligned before dispatch. However as the alignments are likely to be disturbed during transit to some extent and hence must not be relied upon to maintain the factory alignment. Re-alignment is necessary after the complete unit has been leveled on the foundation and again after the grout has been set and foundation bolts have been tightened. The alignment must be checked after the unit is piped up and re-check periodically.

### **FLEXIBLE COUPLING**

A flexible coupling will not compensate for the misalignment of the pump and driver shafts. The purpose of the flexible coupling is to compensate for temperature changes and to permit the movement of the shafts without interference with each other while transmitting power from the driver to the pump. There are two types of misalignments.

- 1) Angular misalignment – shaft with axis concentric, but not parallel.  
Maximum allowable misalignment is 1°

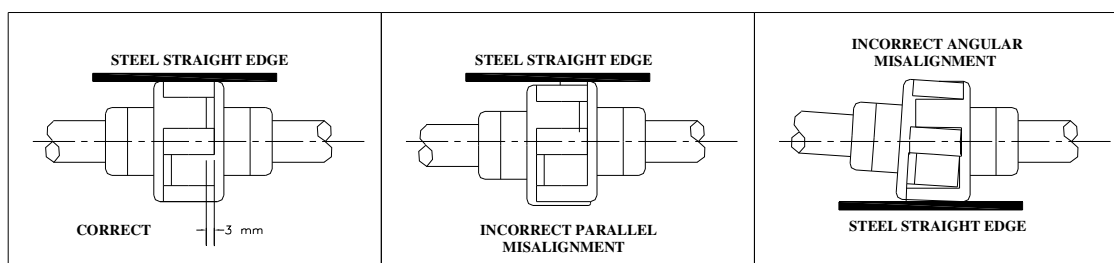

- 2) Parallel misalignment – shaft with axis parallel, but not concentric.  
Maximum allowable misalignment is 0.2 mm

### LEVELING THE UNIT

When the unit is received with the pump and driver mounted on the base plate, it should be placed on the foundation and the coupling halves disconnected. The coupling should not be reconnected until all misalignment operations have been completed. The base plate must be supported evenly on wedges inserted under the four corners so that it will not be distorted or sprung by the uneven distribution of the weight. Adjust the wedges until the shafts of the pump and the driver are in level. Check the coupling faces, suction and discharge flanges for the horizontal and vertical position by means of spirit level.

### FLEXIBLE COUPLING ALIGNMENT

The two halves of the coupling should be at least 3 mm apart so that they cannot touch each other when the driver shaft is rotated. Necessary tools for approximately checking are straight edge or an outside caliper. A check for parallel misalignment is made by placing a straight edge across both coupling periphery at the top, bottom and both the sides. The unit will be in parallel alignment when the straight edge rests evenly on the coupling periphery at all the positions. Care must be taken that the straight edge must be parallel to the axis of the shaft.

### GROUTING

When the alignment is correct, the foundation bolts should be tightened evenly but not too firmly. The unit can then be grouted by working soft concrete under the edges. Foundation bolts should not be fully tightened until the grout is hardened, usually 48 hours after pouring.

### FACTORS THAT MAY DISTURB ALIGNMENT

The unit should be periodically checked for alignment. If the unit does not stay in line after being properly installed, the following are possible causes:

1. Setting, seasoning of the foundation.
2. Pipe strains distorting or shifting the machines.
3. Wear of the bearing.

### PIPING

Both suction and delivery pipes and accessories should be independently supported near the pump, so that when the flanges, bolts are tightened no strains will be transmitted to the pump casing. It is usually advisable to increase the size



of both the suction and delivery pipe at the pump nozzles in order to decrease the loss of head due to friction and for the same reason piping should be arranged with minimum possible bends as possible, or it should be made with long radius wherever possible. The pipe lines should be free from scales, welding residuals etc., and have to be mounted in such a way that they can be connected to suction and delivery flanges without any stress on the pump. It can be achieved by supporting the pipelines at appropriate locations.

### **SUCTION PIPE**

The suction pipe should be as short as possible. This can be achieved by placing the pump near the liquid to be pumped. The suction pipe must be kept free from air leakages. This is particularly important when the suction lift is high. A horizontal suction line must have a gradual rise to the pump. Any high point in the pipe will be filled with air and thus prevent proper operation of the pocket in the top of the reducer and the pipe. Use an eccentric piece instead.

The end of the suction pipe must be well submerged to avoid whirlpools and ingress of air but must be kept clear of any deposits of mud, silt grit etc. The pipe must be away from any side of the wall by 450 mm. the end of the strainer must be provided with a strainer of sufficient open area.

### **DELIVERY PIPE**

A check (non return) valve and a gate or sluice valve (regulating valve) should be installed in the discharge line. The check valve placed between the pump and the gate valve is to protect the pump from excessive pressure and to prevent water running back through the pump in case of failure of the driving machine.

Discharge piping should be provided with a sluice valve adjacent to the delivery flange to control the discharge if required.

### **VACUUM EQUALIZING LINE (AND LIQUID LINE)**

If the pump draws from a system under vacuum an equalizing pipe must be carried from the highest point of the suction line, however as close to the suction flange of the pump as possible, to the top of the feed tank to keep gas bubbles that might have been entrapped in the flow from entering the pump. The line should be fitted with an isolating valve which should be closed only for maintenance work on the pumpset.

Apply sealing liquid (external sealing) to the shaft seal cage to prevent entry of air in the case of the pumps with packed stuffing box. It is convenient to tap the sealing liquid from the delivery line above the non-return valve.

### **FOOT-VALVE**

It is advisable to install a foot-valve to facilitate priming. The foot-valve should have sufficient clear passage for water. Care must be taken to prevent foreign matter from being drawn in to the pump or chocking the foot-valve and for this purpose an efficient strainer should be provided.

### **STUFFING BOXES AND PACKING (only for gland packed pump)**



Stuffing boxes should be carefully cleaned and packing placed in them. Be sure that sufficient packing is placed at the back of the water seal cage. If the water to be pumped is dirty or gritty, sealing water should be piped to the stuffing boxes from clean outside source of supply in order to prevent damage to the packing and shaft. In placing the packing, each packing ring should be cut to the proper length so that ends come together but don't overlap. The succeeding rings of packing should not be pressed too tight, as it may result in burning the packing and cutting the shaft. If the stuffing box is not properly packed, friction in stuffing box prevents turning the rotor by hand. On starting the pump it is well to have the packing slightly loose without causing an air leak, and if it seems to leak, instead of putting too much pressure on the gland, put some heavy oil in the stuffing box until the pump works properly and then gradually tighten up the gland. The packing should be occasionally changed.

### **BALL BEARINGS**

Correct maintenance of ball bearings is essential. The bearing manufacturers give the following as a guide to re-lubrication periods under normal condition.

Three monthly when on continuous duty.

Six monthly when on eight hour per day duty.

The bearings and housings should be completely cleaned and recharged with fresh grease after 2500 hrs. or the nearest pump overhaul time.

### **PRIMING**

No pumping action occurs unless the pump casing is filled with the liquid. Pump casing and suction pipe must therefore be completely filled with liquid and thus all air removed before the pump is started. Several different priming methods can be used depending on the kind of installation and service involved.

- 1) Liquid level above pump level.  
Pump is set below liquid level of source of supply, so that liquid always flows to pump under positive head.
  - 2) Priming with foot-valve.
    - a. When pump is installed on suction lift with foot valve at the end of suction line, fill pump with water from some outside source till all air is expelled and water flows through the air vent.
    - b. When there is liquid under some pressure in the discharge pipe, priming can be effected by bypassing the pressured liquid around the check and gate valve. Of course, the initial priming must be effected from some outside source.
- Note:** In this case, the foot-valve must be capable of withstanding pump pressure and possible surge.
- 3) Priming by ejector  
An ejector operated by steam, compressed air or water under pressure and connected to air vent at the top of casing can be used to remove air from pump and prime the pump on suction lift installations.
  - 4) Priming by dry vacuum pump  
A hand or power pump sucks in all the air from the casing and the suction pipe, and thus primes the system.



**STARTING**

The pump must not be started without being primed. Be sure that the driver rotates in the proper direction as indicated by a direction arrow on the pump casing.

**RUNNING**

On account of its simple construction, the centrifugal pump requires practically no attention while running. Lubrication at the bearings and manipulation of the glands are the only things that need attention from the operator.

**STOPPING**

Before stopping the pump; close the gate valve. This will prevent water hammer on the check valve.

**STUFFING BOXES (only for gland packed pump)**

Do not tighten the glands excessively. A slight dripping of water from the stuffing boxes when pump is running keeps packing in good condition.

**CASING RINGS**

Casing rings are fitted in the casing to reduce the quantity of water leaking back from the high pressure side to the suction side. These casing rings are fitted to maintain a small clearance and depend on the water in the pump for lubrication. When the rings are worn out, the clearance becomes greater and more water passes back into the suction side. The rings must be replaced from time to time to restore the pump efficiency to its normal value.

**SPARE PARTS**

A set of ball bearings, a set of casing rings and a set of gland packing rings / mechanical seal must always be kept at hand to ensure uninterrupted service from the pump. While ordering for spare parts, always give type, size and serial number of the pump as stamped on the number plate.

**PUMP TROUBLE**

When investigating trouble with Kirloskar pumps, always remember that pumps have been tested at the factory and are mechanically correct when sent out. Discounting the possibility of damage during transit, most of the trouble in the field is due to faulty installation. Investigation shows that the majority of troubles with centrifugal pumps result from faulty conditions on the suction side.

**BREAK DOWN-CAUSE-CHECK POINTS**

In case of breakdown we recommend the location of the fault by using the following table.

**BREAKDOWN CHECK POINTS**

|                                   |   |
|-----------------------------------|---|
| Pump does not deliver             | 1 7 8 9 10 11 12 14 15 17 18 19 23 25 26 56<br>57 58              |
| Pump delivers at reduced capacity | 1 2 3 4 5 6 7 8 9 10 11 12 13 14 15 17 18 19<br>20 21 22 56 57 58 |



|   |   |
|---|---|
| Delivery performance deteriorates             | 1 3 7 9 10 11 12 13 14 19 20 21 22 23 24 53<br>57 62                                |
| Pump delivers too much                        | 16 56 57 58   |
| Delivery is interrupted                       | 1 3 6 7 8 9 10 11 12 13 14 15 16 19 22 23<br>25 26 56 57 58 62                      |
| After stopping pump runs in reverse direction | 52  |
| Very noisy                                    | 1 2 5 6 7 8 11 12 13 15 19 20 22 54 55 56<br>57 62                                  |
| Unsteady running of pump                      | 19 20 22 31 32 33 35 36 37 38 39 40 43 44<br>47 48 49 50 51 54 55 58                |
| Stuffing box leaks excessively                | 24 27 28 29 30 31 47 48 49 53   |
| Fumes from stuffing box                       | 22 23 24 25 26 27 28 29 30 41 42 43   |
| Pump rotor locked in standstill position      | 22 45 46 50   |
| Pump is heating up and seizing                | 23 24 25 26 27 28 29 30 40 41 42 45 47 48<br>49 50 54                               |
| Bearing temperature increases                 | 19 20 21 22 31 32 33 34 35 36 37 38 39 40<br>41 42 43 44 45 46 47 48 49 51 54 55 58 |
| Motor will not start                          | 14 22 60  |
| Motor gets hot or burns out                   | 14 22 27 28 40 43 50 55 56 57 58 59 60 61   |
| Motor is difficult to start                   | 14 22 27 28 45 46 50 58 59 60   |

**CHECK POINTS**

1. Suction pipe, foot valve choked.
2. Nominal diameter of suction line too small.
3. Suction pipe not sufficiently submerged.
4. Too many bends in the suction line.
5. Clearance around suction inlet not sufficient.
6. Shut off valve in the suction line in unfavorable position.
7. Incorrect layout of suction line (formation of air pockets).
8. Valve in the suction line not fully open.
9. Joints in the suction line not leak-proof.
10. Air leaking through the suction line and stuffing box etc.
11. Suction lift too high.
12. Suction head too low (difference between pressure at suction connection and vapor pressure too low).
13. Delivery liquid contains too much gas and/or air.
14. Delivery liquid too viscous.



15. Insufficient venting.
16. Number of revolutions too high.
17. Number of revolutions too low.
18. Incorrect direction of rotation (electric motor incorrectly connected, leads of phases on the terminal block interchanged).
19. Impeller clogged.
20. Impeller damaged.
21. Casing rings worn out.
22. Separation of crystals from the flow of pumping liquid (falling below the temperature limit/equilibrium temp).
23. Sealing liquid line obstructed.
24. Sealing liquid contaminated.
25. Lantern ring in the stuffing box is not positioned below the sealing liquid Inlet.
26. Sealing liquid omitted.
27. Packing incorrectly fitted.
28. Gland tightened too much/slanted.
29. Packing not suitable for operating conditions.
30. Shaft sleeve worn in the region of the packing.
31. Bearing worn out.
32. Specified oil level not maintained.
33. Insufficient lubrication of bearings.
34. Ball bearings over-lubricated.
35. Oil/Grease quality unsuitable.
36. Ball bearing incorrectly fitted.
37. Axial stress on ball bearings (no axial clearance for rotor).
38. Bearings dirty.
39. Bearings rusty (corroded).
40. Axial thrust too great because of worn casing rings, relief holes obstructed.
41. Insufficient cooling water supply to stuffing box cooling.
42. Sediment in the cooling water chamber of the stuffing box cooling.
43. Alignment of coupling faulty or coupling loose.
44. Elastic element of coupling worn.
45. Pump casing under stress.
46. Pipeline under stress.
47. Shaft runs untrue.
48. Shaft bent.
49. Rotor parts insufficiently balanced.
50. Rotor parts touching the casing.
51. Vibration of pipe work.
52. Non-return valve gets caught.
53. Contaminated delivery liquid.
54. Obstruction in delivery line.
55. Delivery flow too great.
56. Pump unsuitable for parallel operation.
57. Type of pump unsuitable.
58. Incorrect choice of pump for existing operating conditions.
59. Voltage too low/power supply overloaded.





Enriching Lives

60. Short circuit in the motor.
61. Setting of starter of motor too high.
62. Temperature of delivery liquid too high.