

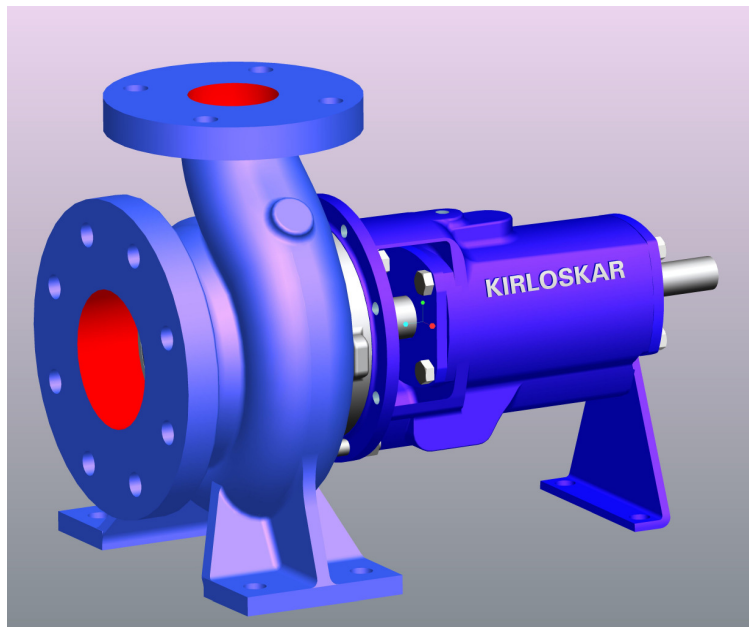

Enriching Lives

**INSTRUCTIONS ON
INSTALLATION,
OPERATION AND
MAINTENANCE FOR
KIRLOSKAR PUMP
TYPE i-CP**



KIRLOSKAR BROTHERS LIMITED

REGD. AND HEAD OFFICE UDYOG BHAVAN, TILAK ROAD PUNE-411002

WARRANTY

We warrant that the pump supplied from us is free from defective material and faulty workmanship. This warranty holds good for a period of 12 months from the date of commissioning the equipment or 18 months from the date of dispatch from our factory, whichever is earlier. Our liability in respect of any complaint is limited to replacing part/parts free of charge ex-works or repairs of the defective part/parts only to the extent that such replacement / repairs are attributable or arise solely from faulty workmanship or defective material.

This warranty holds good only for the products manufactured by us.

KIRLOSKAR BROTHERS LIMITED

CONTENTS:

1. GENERAL
2. SAFETY INSTRUCTIONS
3. EQUIPMENT SCHEDULE
4. TECHNICAL DATA
5. OPERATION
6. MAINTENANCE MANUAL.
7. SPARE PARTS LIST AND CROSS SECTIONAL DRAWINGS.

Note: A copy of **General instructions for installation, operation & maintenance of 'Kirloskar pumps'** is attached at the end of this manual.

1. GENERAL

1.1 The booklet covers instructions for following models of i-CP Pumps

UNIT-30	UNIT-40A	UNIT- 40B	UNIT- 50
40/130	65/160	50/320	65/320
65/130	50/200		80/400
32/160	40/260		
40/160	50/260		
50/160			
32/200			
40/200			

1.2 KIRLOSKAR i-CP pumps are of back pull out design which enables to remove the rotating unit of pump for inspection and repairs without disturbing suction and delivery pipe connections.

1.3 The complete range of i-CP pump is covered by four driving units thereby reducing inventory and achieving interchangeability of parts.

1.4 Pumps when properly installed & given due care in operation & maintenance should operate satisfactorily for a long period.

1.5 When the pump is received, sometime before the actual use of pump, it should be inspected & located in dry place. The shaft should be rotated once in a month to prevent pitting of bearing surfaces.

2 Safety Instructions:

2.1: General Information

Please read the manual thoroughly prior to installation, the Health and Safety instructions shall be read and fully understood. The instructions in this document shall also be read and fully understood.

Whenever the equipment is operated, maintained or used in any way, the procedures detailed these instructions shall be followed. The pump supplied by **Kirloskar Brothers Limited (KBL)** has been designed with safety in mind, where hazards cannot be eliminated; the risk has been minimized by the use of guards and other design features. Some hazards cannot be guarded against and the instructions below **MUST BE COMPLIED WITH** for safe operation. These instructions cannot cover all circumstances. It is the responsibility of the user of the equipment for maintaining safe working practices at all times.

2.1.1 KBL products are designed for installation in designated areas, which are to be kept clean and free of obstructions that may restrict safe access to the controls and maintenance access points.

Pump nameplate is fitted to each unit and must not be removed. Loss of this plate could make identification impossible. This in turn could affect safety and cause difficulty in obtaining spare parts. Such accidental loss or damage if occur, contact KBL immediately.

2.1.2 Access to the equipment should be restricted to the personnel responsible for installation, operation and maintenance and they must be qualified, adequately trained and supplied with the appropriate tools for their respective tasks.

2.1.3 KBL firmly insists that all personnel responsible for installation, operation and maintenance of the equipment must read the manual before any work is done.

2.1.4 Ear defenders should be worn where the specified equipment noise level exceeds locally defined safe levels. Safety glasses or goggles should be worn where working with pressurized systems and hazardous substances. Other personal protection equipment must be worn where local rules apply.

2.2 *DO NOT* wear loose or frayed clothing or jewellery, which could catch on the controls or becomes trapped in the equipment.

2.3 Operation of the equipment for the application other than for which it is supplied can increase the risk from hazards. Please consult KBL before making such change in the application of the equipment.

2.4 Improper installation, operation and maintenance of the product supplied by KBL could result in injury or death.

2.5 Within the manual, safety instructions are marked with safety symbols.

Hazard.



This symbol refers to general mechanical aspects of safety.

Hazard.



This symbol refers to electrical safety.

2.6: Transport handling and storage instructions:

2.6.1 : Transport.

Pumps are dispatched in duly assembled condition. Pumps are protected against corrosion and packed for transport by normal road, rail and sea carriers.

2.6.2: Handling



Crushing hazard.

When lifting the pump or pump set, use lifting equipment having a safe working load rating suitable for the weight specified. Use suitable slings for lifting the pump which is not provided with lifting points.

The use of suitable forklift truck and four chain crane sling equipment is recommended but locally approved equipment rating may be used.

Pump should be slung as shown.

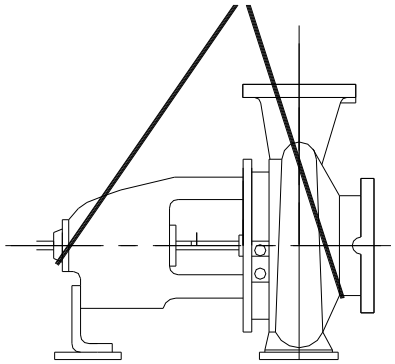

Pump set must be lifted from the lifting holes provided using suitable Four chain lifting equipment.

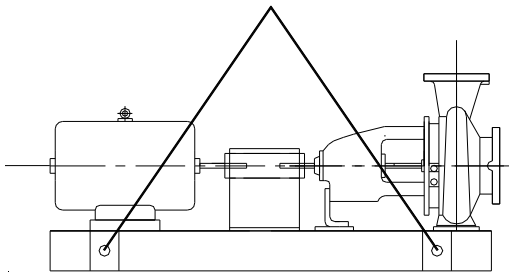

2.6.3: Storage.

2.6.3.1: Temporary storage for up to six weeks.

If the pump unit is not be used immediately it should be stored carefully in a horizontal position, in a sheltered, dry location. Additional rust preventive should be applied to all unpainted carbon steel or cast iron parts, and should not be removed until final installation.

2.6.3.2: Long Term Storage. Do not remove the protection covers or packaging in place until removal is necessary for installation. If the packaging or suction and discharge covers are removed for inspection purposes, cover it

by suitable means afterwards to protect the pump and maintain the safety.



Shearing Hazard.

Do NOT place fingers or hands etc. into the suction or discharge pipe outlets and do NOT touch impeller, if rotated this may cause severe injury.

2.6.3.3: Exposed or Extreme Conditions Storage.

For exposed storage or extreme variants in atmospheric or environmental conditions, please refer to KBL for instructions to suit the conditions acceptable.

3. Equipment schedule:

3.1 Installation:

3.1.2 For location, preparing foundation, installation, alignment, piping, general maintenance, trouble shooting etc. the instructions given in our publication - 'GENERAL INSTRUCTIONS FOR INSTALLATION OPERATION AND MAINTENANCE OF KIRLOSKAR CENTRIFUGAL PUMPS' which is also printed along this booklet must be followed very carefully.

3.1.3 MOUNTING AND ALIGNMENT

A spacer type flexible coupling is used to connect pump shaft to the driver. By using spacer type of coupling, the complete rotating unit can be removed from the volute without removing pump casing or rotor and without disconnecting piping connections. This also avoids any realignment of pump and motor after re-assembly of rotating unit.

3.1.4 ALIGNMENT

ALWAYS REMEMBER “A FLEXIBLE COUPLING IS NOT A UNIVERSAL JOINT”

Correct alignment is essential for the smooth operation of the pump. There are two types of misalignment between the pump shaft and the drive shaft, which are:

- 1) Angular misalignment – shaft with axis concentric, but not parallel in Horizontal as well as Vertical plane.
- 2) Parallel misalignment – shaft with axis parallel, but not concentric, in Horizontal as well as Vertical plane.

This misalignment is checked by using a straight edge as shown in figure given below or by using dial gauge before commissioning the pump set, Alignment must be in 50 microns. Please ensure:

- 1) The pipe connections are flushed and tightened properly.
- 2) Alignment is proper.
- 3) Please ensure stuffing box & suction side connection is intact.

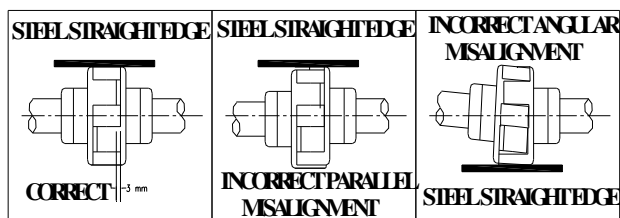

4.0 TECHNICAL DATA:

4.1: Models:

'i-CP' types of pumps are available in models as referred to in 1.1. Only four (driving units) are used for complete range of 'i-CP' pumps. The models covered under individual shaft units are given in interchangeability chart.

i-CP pumps are suitable for clean liquids having temp -10 to +95 deg C.

4.2 INTERCHANGEABILITY CHART

Please see Page No.15

4.3 Direction of rotation:

The direction of rotation is clockwise when viewed from driving end.

4.4 Bearings:

The shaft is supplied with antifriction ball bearing at driving end and non-driving end. The bearing specifications are given below. The designations of bearings are as per SKF catalogue. However, equivalent bearing in type, capacity and dimensions are also used.

Driving Unit	Max. speed (rpm)	Deep Groove Ball Bearing size	
		Driving End	Non Driving End
30	2900	6306-2RS1	6306-2RS1
40A & 40B	2900	6308-2RS1	6308-2RS1
50	1750	6310-2RS1	6310-2RS1

Bearing temperature:

- a) Maximum allowable temperature of bearings: 80°C or 40°C above ambient.
- b) Bearing details:

Both Driving & Non driving end similar bearings are used with C3 clearance.

4.5 Lubrication:

4.5.1 Bearings are factory pre lubricated. Hence no need of any lubrication while operation. Replace bearings after 3 years or 25000 running hours whichever earlier after installation at site. DO NOT APPLY LUBRICANT either in running or standstill condition.

4.6 Stuffing box:

4.6.1 No sealing required -

Stuffing box of the pump is fitted with special design expeller and fluid arrester. With this innovative idea pump will always run without gland packing and without mechanical seal. With innovative design of sleeve allow very small amount of liquid in the stuffing box, practically it repels water back into the pump casing. Very small amount of liquid get entered in the stuffing box and is repelled back in a suction chamber by special design expeller. On back side of expeller fluid arrester arrest the fluid if any. It does not allow the liquid (if any) to go out side. At the same time this fluid arrester will not allow the air to enter into the stuffing box and thus prevent depriming of pump. Hence for this pump no stuffing box sealing or flushing arrangement is required. Only fluid return line must be connected to suction.

5 Operation.

5.1 EQUIPMENT DESCRIPTION:

End suction centrifugal pump type i-CP is from KBL manufactured pump series which conforms to ISO 2858. Pump is meant for catering applications from Lower End Process segments.

The mechanical assembly comprises a rigid shaft, supported deep groove rubber shield ball bearings with a double shrouded impeller mounted in a removable bearing housing assembly. This is attached to an end suction volute casing fitted with wear rings. The bearing housing, shaft and impeller assembly can be withdrawn from the volute for maintenance without disconnection of pipe work.

The discharge branch is positioned vertically upwards while suction branch is horizontal and is at 90° to discharge nozzle. An additional mounting foot is fitted at the outer bearing position for stability.

The complete assembly is of rigid construction, being intended for mounting on suitable base plate with electric motor. A suitable coupling is provided to transmit the rotational drive between pump and motor. A spacer coupling must be used to allow the removal of the pump rotating assembly without disconnecting suction pipe, discharge pipe and motor.

Pump is with unique feature of zero leakage & without gland packing & mechanical seal.

5.2 EQUIPMENT OPERATION.

5.2.1 Before starting the pump check the following:

- 1) The pump rotates freely by hand.
 - 2) The direction of rotation of driver. It should correspond to the direction of rotation of pump.
 - 3) The pump casing and the suction pipeline is fully primed with the liquid.
 - 4) Valve on delivery side is closed.
- The cock for pressure gauge connection is closed.

5.2.2 Starting the pump

- 1) While starting the pump ensure delivery valve is closed. Let the prime mover pickup it s full speed.
- 2) Open the valve on delivery line gradually.
- 3) Regulate the required flow by adjusting the delivery valve.
- 4) Open the cock for pressure gauge connection.

5.2.3 During running the pump check the following things and regulate if needed

- 1) The pump is running smooth.
- 2) The bearings are not getting abnormally hot.
- 3) Head and capacity developed by the pump is as specified.
- 4) Power consumption is within limit.
- 5) Ensure that there is no mechanical friction in the pipe.
- 6) Stop the pump immediately, if any defects are detected.

5.2.4 During stopping the pump

- 1) Close the valve on the delivery line.
 - 2) Stop the motor.
 - 3) If the pump is not required to be operated for a long time, drain the casing completely. If the pump is required to be stored for a long time, the bearing housing should be dried internally with hot air and should be flushed with moisture free protective such as light oil or kerosene
- Be aware of the hazards relating to the pumped fluid, especially the danger from inhalation from noxious and toxic gases, skin and eye contact or penetration.



Electric shock and accidental starting hazard:

Isolate the equipment before any maintenance work is done. Switch off the mains supply, remove fuses, apply

lockouts where applicable and affix suitable isolation warning signs to prevent inadvertent re-connection.

In order to avoid the possibility of maintenance personnel inhaling dangerous fumes or vapours, it is recommended that maintenance work be carried out away from the pump location by removal of the rotating unit assembly to a suitable maintenance area.

Specific maintenance data:

6.2. Overhauling:

Procedure for dismantling and re-assembly

While dismantling and re-assembling, the cross-sectional assembly drawing and specification part list should be referred.

6.2.1 Dismantling:

Follow the following simple steps to dismantle the pump.

6.2.1.1 Isolate power supply to motor.

6.2.1.2 Shut off valves controlling flow to and from the pump.

6.2.1.3 Drain the liquid from pump by removing the drain plug, or open the pump casing drain cock.

6.2.1.4 We recommend matching the punch mark of the coupling halves.

6.2.1.6 In case of the pumps with spacer type flexible couplings, disconnect coupling (pump half and motor half) from the coupling spacer and remove coupling spacer. In case of ordinary flexible couplings, remove the motor from the base.

6.2.1.7 Remove the support foot hold down bolts.

6.2.1.8 Adjust string or chain tension to support the weight of the back pull out assembly.

6.2.1.9 Remove the hexagonal nuts from casing stud holding the bearing housing (24000) to pump casing (10500).

6.2.1.10 Screw the release bolts provided in casing cover. Turn bolts evenly through a quarter turn at both sides.

6.2.1.11 Slightly pull out the driving unit till impeller (15100) clears the pump casing (10500).

6.2.1.12 Place this rotating unit on a table or clear place for further Dismantling.

6.2.1.13 Remove casing gasket (51100).

6.2.1.14 Unscrew the impeller nut (33000).

6.2.1.15 Take out the impeller (15100) from pump shaft (18000). Remove the Gasket between impeller and shaft sleeve (51501).

6.2.1.16 Removal of stuffing box:
For this following steps should be taken: Loosen the cover plate (23100) by taking out allen headed cap screws used for clamping of the cover plate. Take out the casing cover (22000) along with stuffing box bush (35000).

a) Clamped casing cover units – The following pumps have this type of construction.

40/130	65/130
	65/160

b) Bolted casing cover units – The following pumps have this type of construction.

32/160	40/160	50/160	
32/200	40/200	50/200	
40/260	50/260		
	50/320	65/320	
			80/400

- 1) Remove the stuffing box bush (35000) from Casing cover.
- 2) Remove the shaft sleeve (31000) from the shaft alongwith expeller.
- 3) Loosen the grub screw of the expeller (which will be for holding with sleeve) & then remove the expeller (16300).
- 4) Remove cover plate (23100) which is fitted with fluid arrester.

6.2.1.17 Remove the nuts holding the pump casing/casing cover (10500/22000) and bearing housing (24000).

6.2.1.18 Take out bearing housing (24000).

6.2.1.19 Remove pump half coupling after unscrewing grub screw.

Caution:

Coupling half should be removed with the help of suitable extraction device. To avoid damage to the bearings, coupling half should not be knocked out of shaft.

6.2.1.20 Take out coupling key (32100).

6.2.1.21 Loosen the bolts holding bearing cover (27000) (driving end) Remove carefully bearing cover.

6.2.1.22 Remove screws for bearing cover draw DE bearing cover (27000) out of bearing housing (24000) and off of shaft.

6.2.1.23 Carefully remove the bearing housing circlips ring (48500)

6.2.1.24 The second bearing housing circlip ring (48600) can now be removed.

6.2.1.25 Force shaft (18000) carefully in the direction of driving end. Shaft will come out along with the bearings.

6.2.1.26 The pump shaft (18000) can now be carefully driven from its bearing housing (24000), in the direction of the

drive end, for the DE bearing (26000) to just clear the bearing housing (24000).

6.2.1.27 The NDE bearing (26000) can be pressed through the end of the bearing housing. Care must be taken to ensure the bearing passes centrally through the bore of bearing housing.

6.2.1.28 Take out the driving end bearing (26001) with the help of puller. DE bearing (26000) can be pressed off drive end of shaft (18000), after the careful removal of the shaft circlip ring.

6.2.1.29 NDE bearing (26000) can be pressed off impeller end of shaft (18000).

Caution:

- 1) Push the sleeve on arbour press with uniform pressure.
- 2) Steps 6.2.1.28 to 6.2.1.29 are to be followed only if bearings are damaged and to be replaced.

During and after dismantling:

1. Renew bearings if they do not rotate smoothly with no sign of jamming and freely but with slackness.
2. Mount shaft between point centres or on rollers and place stem of dial indicator in contact with the shaft. Set the indicator dial at zero and turn the shaft slowly by hand. Reading at any point must not vary more than 0.05mm.
3. Examine shaft sleeve for wear and check for true. It is important that the surface of the sleeve, which runs in the stuffing box, against Fluid arrester is concentric and not scored or damaged. If true of shaft is satisfactory, remount the shaft as in 2 above, but with the sleeve fitted and check for true with dial indicator. Indicator readings must not vary more than 0.08mm.

6.2.2 Re-assembly:

This procedure covers re-assembly of pump after complete dismantling of the pump. Before re-assembly, all the parts except cover plate (which is fitted with fluid arrester) should be thoroughly cleaned in kerosene, petrol or benzene to remove the dust, rust etc. After cleaning the necessary parts should be replaced.

6.2.2.1 The assembly of the pump unit is carried out in the reverse order of dismantling.

6.2.2.2 Handle fluid arrester assembly i.e. alongwith cover plate carefully. While reassembly ensure that there is no scratch or dent on sleeve especially below fluid arrester. Do not remove spring from the fluid arrester.

Caution:

Use arbour press while fitting the bearings.

c) Maintenance tools required:

No special tools are required for dismantling and reassembling. Toolbox containing a general set of tools such as different size ring spanners, torque wrenches, open ended spanners, light ball peen hammer, wooden mallet, various sizes Allen keys etc serves the purpose. It is important to ensure that the suitable lifting equipment is available and that the work is carried out in clean area.

6.3 PREVENTIVE MAINTENANCE:

Preventive maintenance schedule is the periodical checks and precautions by which possibilities of failures and breakdowns are minimized.

6.3.1 Daily checks:

6.3.1.1 Hourly record of suction and delivery pressure, discharge quantity input to the pump driver should be maintained.

6.3.1.2 Bearing temperature.

6.3.1.3 Noise and vibrations are the first signs of impending troubles like cavitation, air lock, bearing failure, choking of impeller or casing and such other operating troubles. The pump performance should therefore be checked for noise and vibrations.

6.3.2 Periodical checks:

6.3.2.1 The temperature of the bearing should be measured by thermometer. Safe maximum working temperature of the bearing is 80°C.

6.3.2.2 The alignment of the pump unit should be checked. Due to operational vibrations, atmospheric temperature or stress induced by the weight of the piping, the alignment may get disturbed.

6.3.2.3 Calibrate the measuring instrument.

6.3.3 Annual checks:

6.3.3.1 The pump should be overhauled completely to check the clearance and to replace worn-out parts. Clearance between impeller and casing rings, shaft sleeves and stuffing box bush and shaft sleeve etc are very important.

6.3.3.2 The effects of liquid handled on pump components should be checked. If abnormal corrosion, erosion is observed, the component should be replaced with that of suitable material.

6.3.3.3 The auxiliary pipelines and functioning of the auxiliary system should be checked. The main pipe also should be checked for scaling, leakage etc.

6.3.3.4 The measuring instruments, gauges etc should be recalibrated.

6.3.3.5 Full running test may be carried out to check whether there is any fault in the performance, in comparison with original performance.

6.3.3.6 Piping supports should be checked so that the pipes do not induce unwanted stresses on the pump.

6.3.4 CORRECTIVE MAINTENANCE

PUMP TROUBLE

When investigating trouble with Kirloskar pumps, always remember that pumps have been tested at the factory and are mechanically correct when sent out. Discounting the possibility of damage during transit, most of the trouble in the field is due to faulty installation. Investigation shows that the majority of troubles with centrifugal pumps result from faulty conditions on the suction side.

BREAK DOWN-CAUSE-CHECK POINTS

In case of breakdown we recommend the location of the fault by referring the table for 'Break Down Check Points' given at the end of this manual.

GENERAL INFORMATION & SAFETY REQUIREMENTS:-

1.0 The products supplied by KBL have been designed with safety in mind. Where hazards cannot be eliminated, the risk has been minimized by the use of guards and other design features. Some hazards cannot be guarded against and the instructions below **MUST BE COMPLIED**

WITH for safe operation. These instructions cannot cover all circumstances; YOU are responsible for using safe working practices at all times.

- 1.1 KBL products are designed for installation in designated area, which are to be kept clean and free of obstructions that may restrict safe access to the controls and maintenance access points.

A Pump Duty Nameplate is fitted to each unit and must not be removed. Loss of this plate could make identification impossible. This in turn could affect safety and cause difficulty in obtaining spare parts. If accidental loss or damage occurs, contact KBL immediately.

- 1.2 Access to the equipment should be restricted to the personnel responsible for installation, operation and maintenance and they must be trained, adequately qualified and supplied with appropriate tools for their respective tasks.

- 1.3 Most accidents involving product operation, maintenance and repair are caused by failure to observe safety rules or precautions. An accident can often be avoided by recognizing potentially situations before an accident occurs. A person must be aware of potential hazard associated in activities of installation, operation and maintenance.

- 1.4 KBL requires that, all personnel that are responsible for installation, operation or maintenance of the equipment, have access to and study the product instruction manual BEFORE any work is done and that they will comply with all local and industry based safety instructions and regulations.

- 1.5 Ear defenders should be worn where the specified equipment noise level exceeds locally defined safe levels. Safety glasses

or goggles should be worn where working with pressurized systems and hazardous substances. Other personnel protection equipment must be worn where local rules apply. Wear safety shoes, helmets and cotton overalls (apron) when you enter pump house. Noise level should not exceed 90dbA and 110 dbA for motor driven and engine driven pumps respectively.

- 1.6 Do not wear loose clothing or jewellery which could catch on the controls or become trapped in the equipment.

- 1.7 Read the instruction manual before installation, operation and maintenance of the equipment. Check and confirm that the manual is relevant copy by comparing pump type on the nameplate and with that on the manual.

- 1.8 Note the 'Limits of product application – permissible use' specified in the manual. Operation of the equipment beyond these limits will increase the risk from hazards noted below and may lead to premature and hazardous pump failure.

- 1.9 Clear and easy access to all controls, gauges and dials etc. must be maintained at all times. Hazardous or flammable materials must not be stored in pump rooms unless safe areas or racking and suitable containers have been provided.

- 1.10 Use suitable earthing and tripping devices for electrical equipments.

1.11 IMPROPER INSTALLATION, OPERATION OR MAINTENANCE OF THIS KBL PRODUCT COULD RESULT IN INJURY OR DEATH.

If tool, procedure work method or operating technique not specifically

recommended by KIRLOSKAR BROTHERS LIMITED is used, it should be ensured that it is a safe for personnel around and others. It should also be ensured that the product will not be damaged or made unsafe by the operation or repair procedures you choose.

2.0 SAFETY INSTRUCTIONS WHILE HANDLING AND STORAGE

When lifting the pump, use the lifting points specified on general arrangement drawing. Use lifting equipment having a safe working load rating suitable for the weight specified. Use suitable slings for lifting pump which is not provided with lifting points. The use of fork-lift truck and chain crane sling equipment is recommended but locally approved equipment of suitable rating may be used.

Do not place fingers or hands etc. into the suction or discharge pipe outlets and do not touch the impeller, if rotated this may cause severe injury. To prevent ingress of any objects, retain the protection covers or packaging in place until removal is necessary for installation. If the packaging or suction and discharge covers are removed for inspection purposes, replace afterwards to protect the pump and maintain safety.

3.0 SAFETY INSTRUCTIONS WHILE ASSEMBLY & INSTALLATION

Shaft alignment must be checked again after the final positioning of the pump unit and connection to pipe work as this may have disturbed the pump or motor mounting positions. If hot liquids (above 80°C) are being pumped, alignment should be checked and reset with the pump and motor at their normal operating temperature. If this is not possible, KBL can supply estimated initial offset figures

to suit extreme operating temperatures. Failure to support suction and delivery pipe work may result in distortion of the pump casing, with the possibility of early pump failure.

4.0 SAFETY INSTRUCTIONS WHILE COMMISSIONING & OPERATION.

Never attempt adjustments while the pump is running, unless otherwise specified in the operation, maintenance manual.

Do not touch any moving or rotating parts. Guards are provided to prevent access to these parts, where they have been removed for maintenance they must be replaced before operating the equipment.

Check that the pump is primed. Pump should never be run dry as the pumped liquid acts, as lubricant for the close running fits surrounding impeller and damage will be incurred.

Do not touch surfaces which during normal running will be sufficiently hot to cause injury. Note that these surfaces will remain hot after the pump has stopped, allow sufficient time for cooling before maintenance. Be cautious and note that other parts of the pump may become hot if a fault is developing.

Do not operate pumps in temperatures below freezing point of liquid, without first checking that the pumped fluid is not frozen and the pump is free to turn. Pumps in these environments should be drained down during inactivity and re-primed before starting.

In addition to local or site regulations for noise protection, KBL recommend the use

of personal ear protection equipment in all enclosed pump rooms and particularly those containing diesel engines. Care must be taken to ensure that any audible alarm or warning signal can be heard with ear defenders worn.

Be aware of the hazards relating to the pumped fluid, especially the danger from inhalation of noxious and toxic gases, skin and eye contact or penetration. Obtain and understand the hazardous substance data sheets relating to the pumped fluid and note the recommended emergency and first aid procedures.

5.0 SAFETY INSTRUCTIONS WHILE MAINTENANCE & SERVICING

Do not attempt repairs, you do not understand. Use proper tools.

Before attempting any maintenance on a pump particularly if it has been handling any form of hazardous liquid, it should be ensured that the unit is safe to work on. The pump must be flushed thoroughly with suitable cleaner to purge away any of the product left in the pump components.

This should be carried out by the plant operator and a certificate of cleanliness obtained before starting work. To avoid any risk to health it is also advisable to wear protective clothing as recommended by the site safety officer especially when removing old packing which may be contaminated.

Isolate the equipment before any maintenance work is done. Switch off the main supply, remove fuses, apply lockouts where applicable and affix suitable isolation warning signs to prevent inadvertent reconnection. In order to avoid the possibility of maintenance

personnel inhaling dangerous fumes or vapors locations by removal of bearing housing and shaft assembly to a suitable maintenance area.

Check and ensure that the pump operates at below the maximum working pressure specified in the manual or on the pump nameplate and before maintenance, ensure that the pump is drained down.

Wear a suitable mask or respirator when working with packing and gasket components which contain fibrous material, as these can be hazardous when the fibrous dust is inhaled. Be cautious, if other supplier's components have been substituted for genuine KBL parts, these may then contain hazardous materials.

Store all oily rags or other flammable material in a protective container in a safe place. Do not weld or flame cut on pipes/tubes that contents flammable fluids. Clean them thoroughly with nonflammable solvent before welding or flame cutting on them. Use solvent/chemical resistant gloves for hand protection.

Dispose of all wastes like gaskets, Batteries, packing material etc. in accordance with local regulations. Normally this would involve incineration of liquid waste and controlled landfill of polymerized material.

Adequacy of suitable crane should be checked before lifting the pump/pump components. Also condition of pulleys, chain and lifting shackles should be checked before use.

INTERCHANGEABILITY CHART OF i-CP PUMP COMPONENTS

PART CODE NO.	PART DESCRIPTION	QTY	PUMP SIZE													
			DRIVING UNIT - 30							DRIVING UNIT - 40A				40B	UNIT 50	
			40/130	65/130	32/160	40/160	50/160	32/200	40/200	65/160	50/200	50/260	40/260	50/320	65/320	80/400
105	PUMP CASING.	1	1	2	3	4	5	6	7	8	9	10	11	12	13	14
151	IMPELLER.	1	1	2	3	4	5	6	7	8	9	10	11	12	13	14
220	CASING COVER.	1	1	1	2	2	2	3	3	4	5	6	6	7	8	9
190	WEARING RING [SUCTION].	1	1	2	3	4	5	6	7	8	9	10	11	12	13	14
191	WEARING RING [ST.BOX].	1	--	--	--	--	--	--	--	--	--	--	--	1	2	3
251	SUPPORT FOOT.	1	1	2	3	3	2	2	2	4	4	5	5	6	7	8
311	SHAFT SLEEVE.	1	1	1	1	1	1	1	1	2	2	2	2	2	3	3
240	BEARING HOUSING.	1	1	1	1	1	1	1	1	2	2	2	2	3	4	4
270	BEARING COVER [DE].	1	1	1	1	1	1	1	1	2	2	2	2	2	3	3
271	BEARING COVER [NDE].	1	1	1	1	1	1	1	1	2	2	2	2	2	3	3
260	BALL BEARING [DE]	1	1	1	1	1	1	1	1	2	2	2	2	2	3	3
260	BALL BEARING [NDE].	1	1	1	1	1	1	1	1	2	2	2	2	2	3	3
180	PUMP SHAFT.	1	1	1	1	1	1	1	1	2	2	2	2	2	3	3
330	IMPELLER NUT.	1	1	1	1	1	1	1	1	2	2	2	2	2	3	3
320	KEY FOR IMPELLER.	1	1	1	1	1	1	1	1	2	2	2	2	2	3	3
321	KEY FOR COUPLING.	1	1	1	1	1	1	1	1	2	2	2	2	2	3	3
163	EXPELLER	1	1	1	1	1	1	1	1	2	2	2	2	2	3	3
500	FLUID ARRESTER	1	1	1	1	1	1	1	1	2	2	2	2	2	3	3
231	COVER PLATE	1	1	1	1	1	1	1	1	2	2	2	2	2	3	3
350	STUFFING BOX BUSH	1	1	2	1	1	2	1	1	3	3	3	3	3	4	4

Tapping connections chart:

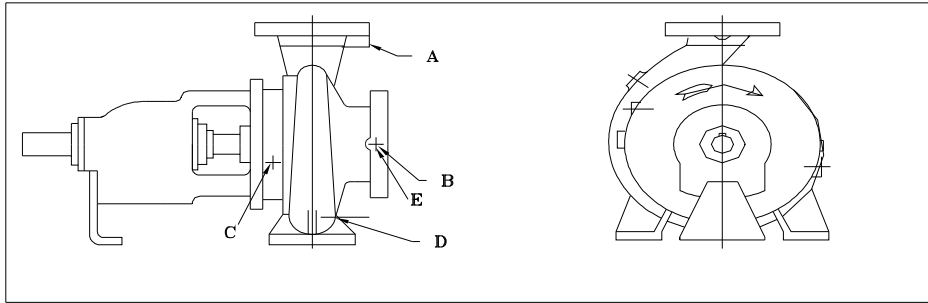

Sr no	Code of pipe conn.	Description	Size of connections		
			i-CP – 30	i-CP – 40	i-CP – 50
			BSP	BSP	BSP
1	A	Gauge connection discharge side	1/4	1/4	1/4
2	B	*Suc. gauge / vacuum equalizing connection			
3	C	Recirculation conn. from stuffing box (casing cover)	1/4	1/4	1/4
4	E	Recirculation conn. to pump casing	1/4	1/4	1/4
5	D	Casing Drain	1/2	1/2	1/2

* Or Suction gauge should be given in suction piping at site.

7.0 SPARE PARTS LIST AND CROSS SECTIONAL DRAWINGS

105	PUMP CASING	* 320	KEY FOR IMPELLER
* 151	ENCLOSED IMPELLER	321	KEY FOR COUPLING
* 163	EXPELLER	330	IMPELLER NUT
* 180	PUMP SHAFT	* 350	STUFFING BOX BUSH
* 190	CASING WEAR RING (SUC)	* 479	HELICOIL INSERT
* 191	CASING WEAR RING (DEL)	485	INTERNAL CIRCLIP
220	CASING COVER	486	EXTERNAL CIRCLIP
* 231	COVER PLATE	* 511	GASKET FOR CASING COVER
* 500	FLUID ARRESTER	* 515	GASKET FOR SHAFT SLEEVE & IMPELLER
240	BEARING HOUSING	* 516	GASKET FOR COVER PLATE
251	SUPPORT FOOT	532	RECIRCULATION PIPE
260	DEEP GROOVE BALL BEARING	* 682	GASKET FOR IMPELLER & IMPELLER NUT
270	BEARING COVER		
* 310	SHAFT SLEEVE		



GENERAL OUTLINE DIMENSIONS DRAWING OF 'i-CP' PUMPS

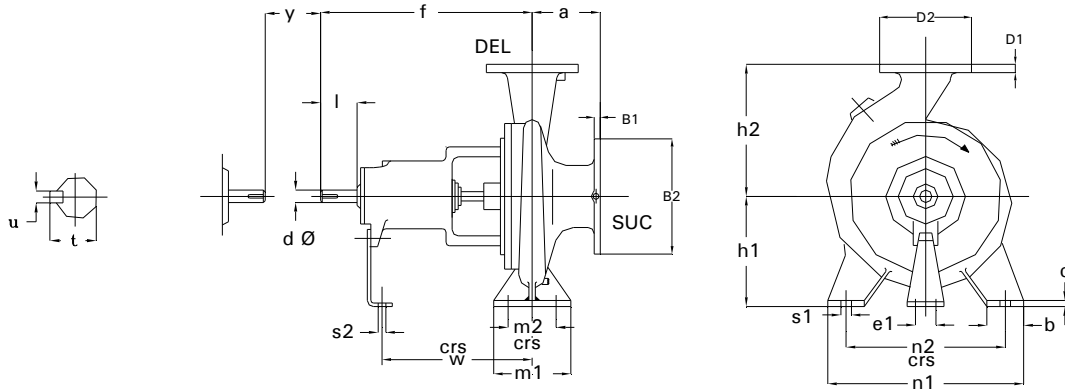

FLANGE DRILLING AS PER DIN EN 1092.2 PN16 STANDARD.

PUMP SIZE	DRIVING UNIT	PUMP DIMENSIONS										FOOT DIMENSIONS								SHAFT END											
		DEL	SUC	a	f	h1	h2	B1	B2	D1	D2	b	c	m1	m2	n1	n2	w	s1	s2	e1	d	l	t	u	y					
32/160	30	32	50	80	385	132	160	22	165	20	140	50	14	100	70	240	190	285	14	15	110	24	50	27	8	100					
32/200						160	180	22	165	20	140					210	160														
40/130		40	65			100	112	140	24	185	20					150	265										212				
40/160							132	160	24	185	20					150	265										212				
40/200							160	180	24	185	20					150	265										212				
50/160		50	80			100	160	160	180	24	200					22	165										65	125	95	280	212
65/130		65	100					160	180	26	220					24	185														
40/260	40A	40	65	100	500	180	225	24	185	20	150	65	14	125	95	320	250	370	14	15	110	32	80	35	10	140					
50/200						50	80	125	160	200	24	200		22	165	50	100										70	265	212		
50/260		180	225						24	200	22	165	65	125	95	320	250														
65/160		65	100			100	160	200	26	220	24	185				280	212														
50/320	40B	50	80	125	500	225	280	24	200	22	165	65	14	125	95	345	280	370	14	15	110	32	80	35	10	140					
65/320	50	65	100	125	530	225	280	26	220	24	185	80	16	160	120	400	315	370	18	15	110	42	110	45	12	140					
80/400						80	125	280	355	28	250					24	200										435	355			

TC19110007-0

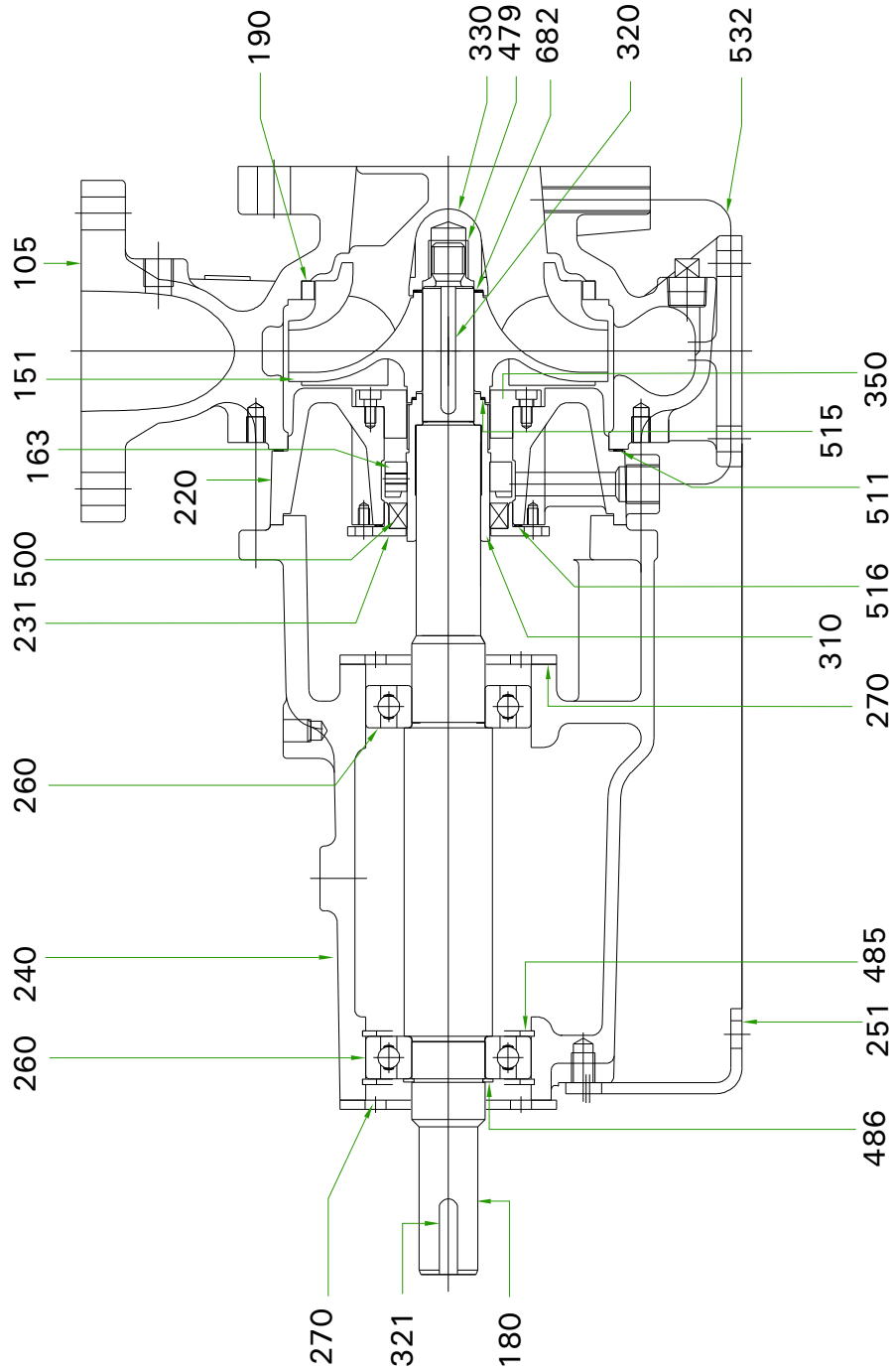

CROSS SECTIONAL ASSEMBLY OF i-CP 40/130, 65/130, 65/160 PUMP

TC19110009-0

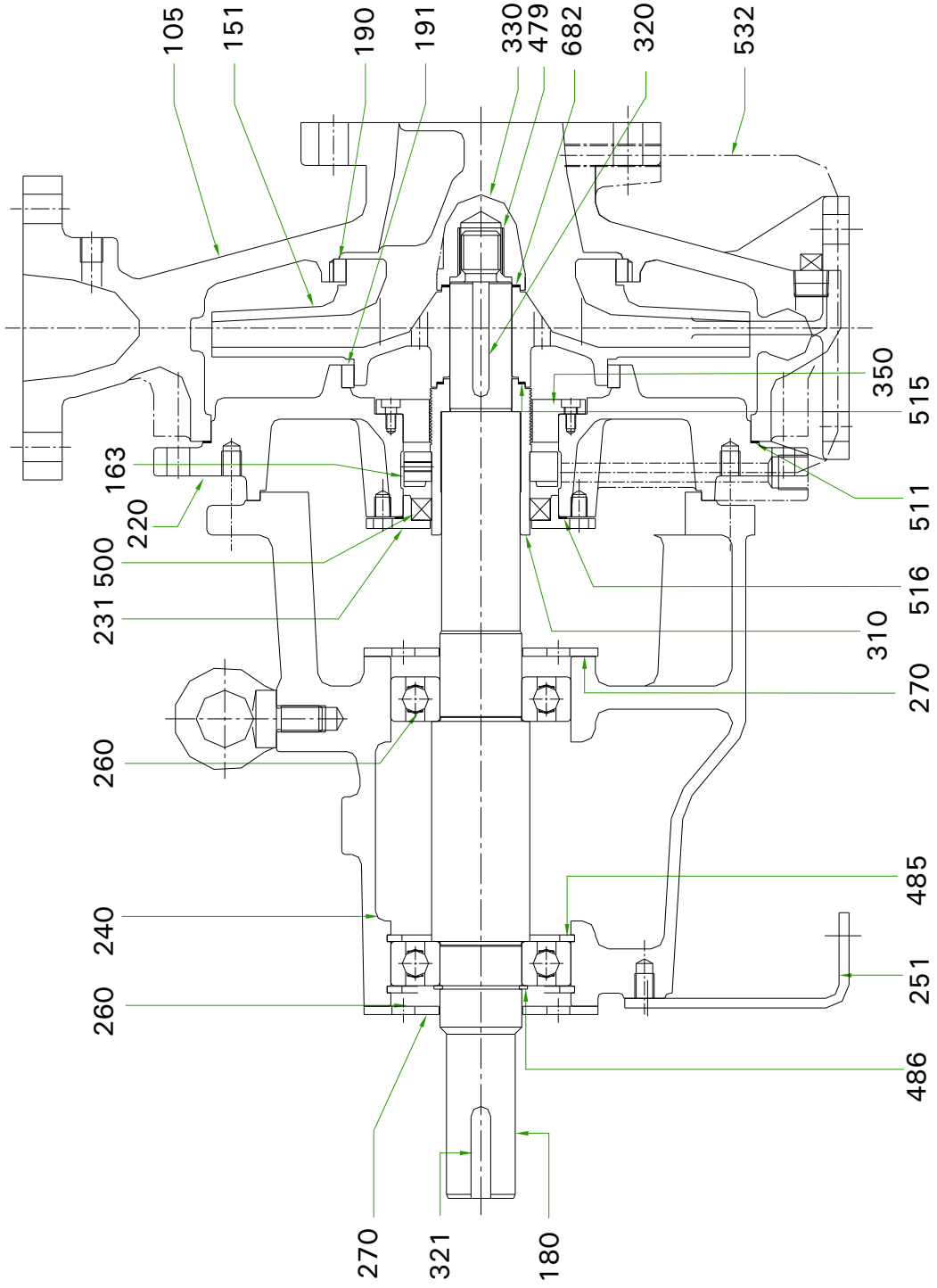

CROSS SECTIONAL ASSEMBLY OF i-CP 65/320, 80/400 PUMP

GENERAL INSTRUCTIONS FOR MAINTENANCE, OPERATION & MAINTENANCE OF KIRLOSKAR CENTRIFUGAL PUMPS

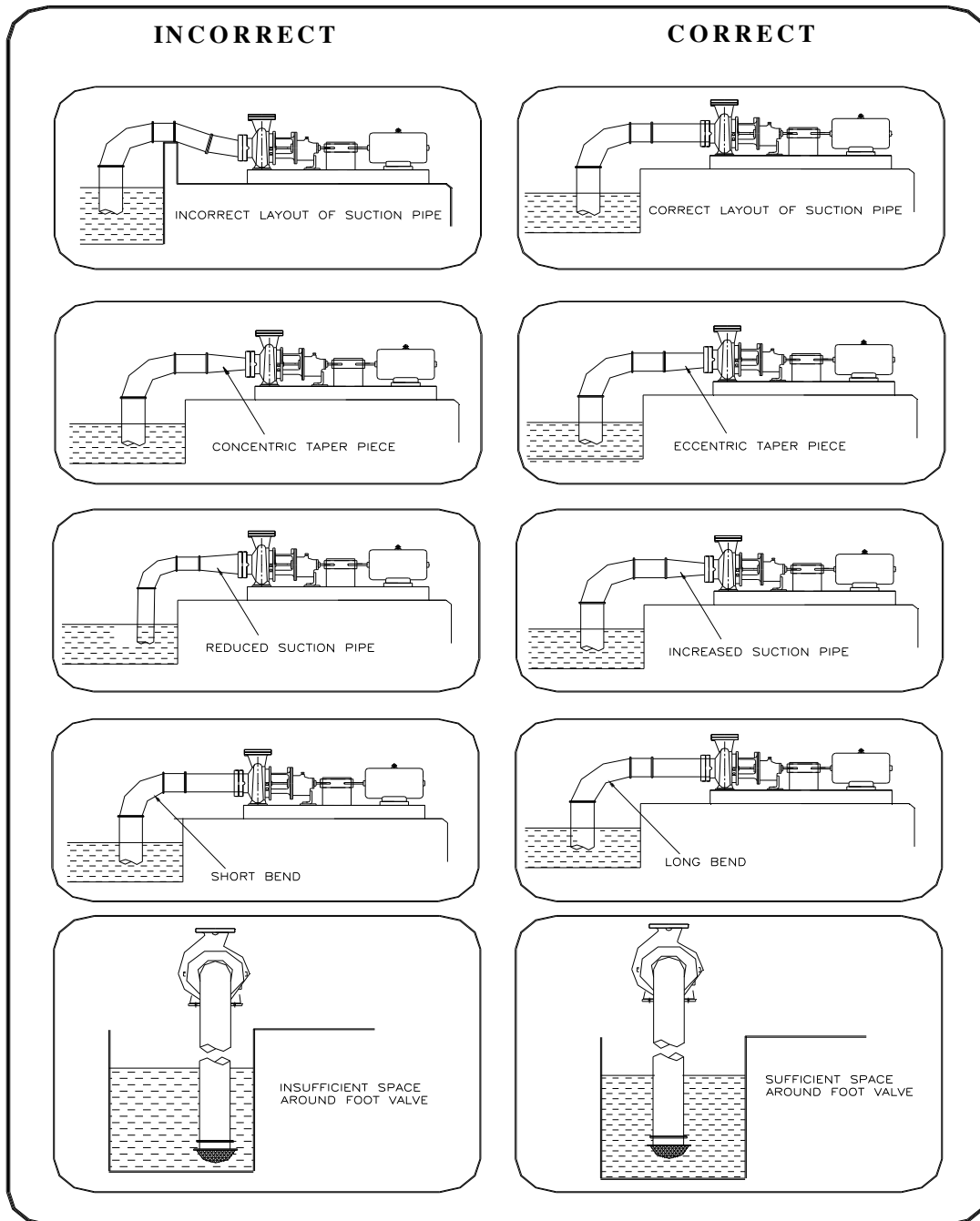

GENERAL INSTRUCTIONS FOR MAINTENANCE, OPERATION & MAINTENANCE OF KIRLOSKAR CENTRIFUGAL PUMPS

WARNING

The equipment supplied is designed for specific capacity, speed pressure and temperature. Do not use the equipment beyond the capacities for which it is manufactured. The equipment manufactured is also shop tested for satisfactory performance and if it is operated in excess of the conditions for which it is manufactured, the equipment is subjected to excessive stresses and strains.

LOCATION

The pump should be located as near the liquid source as possible. This will minimize suction lift and pump will give better performance.

Ample space should be provided on all the sides so that the pump can be inspected while in operation and can be serviced whenever required.

FOUNDATION

The foundation should be sufficiently substantial to sustain any vibrations and to form a permanent rigid support for the base plate. This is important in maintaining the alignment of a directly connected unit. A concrete foundation on a solid base is advisable. Foundation bolts of the proper size should be embedded in the concrete located by a drawing or template. A pipe sleeve of two and one half diameter larger than the bolt should

be used to allow movement for the final position of the foundation bolts.

ALIGNMENT

Pumps and the drivers supplied by the manufacturers, mounted on a common base plate are accurately aligned before dispatch. However as the alignments are likely to be disturbed during transit to some extent and hence must not be relied upon to maintain the factory alignment. Re-alignment is necessary after the complete unit is been leveled on the foundation and again after the grout has been set and foundation bolts have been tightened. The alignment must be checked after the unit is piped up and re-check periodically.

FLEXIBLE COUPLING

A flexible coupling will not compensate for the misalignment of the pump and driver shafts. The purpose of the flexible coupling is to compensate for temperature changes and to permit the movement of the shafts without interference with each other while transmitting power from the driver to the pump. There are two types of misalignments.

- 1) Angular misalignment – shaft with axis concentric, but not parallel.
- 2) Parallel misalignment – shaft with axis parallel, but not concentric.

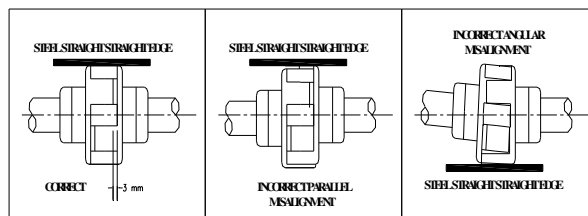

LEVELING THE UNIT

When the unit is received with the pump and driver mounted on the base plate, it should be placed on the foundation and the coupling halves disconnected. The coupling should not be reconnected until all misalignment operations have been completed. The base plate must be supported evenly on wedges inserted under the four corners so that it will not be distorted or sprung by the uneven distribution of the weight. Adjust the wedges until the shafts of the pump and the driver are in level. Check the coupling faces, suction and discharge flanges for the horizontal and vertical position by means of spirit level.

FLEXIBLE COUPLING ALIGNMENT

The two halves of the coupling should be at least 3 mm apart so that they cannot touch each other when the driver shaft is rotated. Necessary tools for approximately checking are straight edge or an outside caliper. A check for parallel misalignment is made by placing a straight edge across both coupling periphery at the top, bottom and both the sides. The unit will be in parallel alignment when the straight edge rests evenly on the coupling periphery at all the positions. Care must be taken that the straight edge must be parallel to the axis of the shaft.

GROUTING

When the alignment is correct, the foundation bolts should be tightened evenly but not too firmly. The unit can then be grouted by working soft concrete under the edges. Foundation bolts should not be fully tightened until the grout is hardened, usually 48 hours after pouring.

FACTORS THAT MAY DISTURB ALIGNMENT

The unit should be periodically checked for alignment. If the unit does not stay in

line after being properly installed, the following are possible causes:

- a) Setting, seasoning of the foundation.
- b) Pipe strains distorting or shifting the machines.
- c) Wear of the bearing.

PIPING

Both suction and delivery pipes and accessories should be independently supported near the pump, so that when the flanges, bolts are tightened no strains will be transmitted to the pump casing. It is usually advisable to increase the size of both the suction and delivery pipe at the pump nozzles in order to decrease the loss of head due to friction and for the same reason piping should be arranged with minimum possible bends as possible, or it should be made with long radius wherever possible. The pipe lines should be free from scales, welding residuals etc., and have to be mounted in such a way that they can be connected to suction and delivery flanges without any stress on the pump. It can be achieved by supporting the pipelines at appropriate locations.

SUCTION PIPE

The suction pipe should be as short as possible. This can be achieved by placing the pump near the liquid to be pumped. The suction pipe must be kept free from air leakages. This is particularly important when the suction lift is high. A horizontal suction line must have a gradual rise to the pump. Any high point in the pipe will be filled with air and thus prevent proper operation of the pocket in the top of the reducer and the pipe. Use an eccentric piece instead.

The end of the suction pipe must be well submerged to avoid whirlpools and ingress of air but must be kept clear of any deposits of mud, silt grit etc. The pipe must be away from any side of the wall by 450 mm. the end of the strainer

must be provided with a strainer of sufficient open area.

DELIVERY PIPE

A check (non return) valve and a gate of sluice valve (regulating valve) should be installed in the discharge line. The check valve placed between the pump and the gate valve is to protect the pump from excessive pressure and to prevent water running back through the pump in case of failure of the driving machine.

Discharge piping should be provided with a sluice valve adjacent to the delivery flange to control the discharge if required.

VACUUM EQUALIZING LINE (AND LIQUID LINE)

If the pump draws from a system under vacuum an equalizing pipe must be carried from the highest point of the suction line, however as close to the suction flange of the pump as possible, to the top of the feed tank to keep gas bubbles that might have been entrapped in the flow from entering the pump. The line should be fitted with an isolating valve which should be closed only for maintenance work on the pump set.

Apply sealing liquid (external sealing) to the shaft seal cage to prevent entry of air in the case of the pumps with packed stuffing box. It is convenient to tap the sealing liquid from the delivery line above the non-return valve.

FOOT-VALVE

It is advisable to install a foot-valve to facilitate priming. The foot-valve should have sufficient clear passage for water. Care must be taken to prevent foreign matter from being drawn in to the pump or chocking the foot-valve and for this purpose an efficient strainer should be provided.

STUFFING BOXES AND PACKING (only for gland packed pump)

Stuffing boxes should be carefully cleaned and packing placed in them. Be sure that sufficient packing is placed at

the back of the water seal cage. If the water to be pumped is dirty or gritty, sealing water should be piped to the stuffing boxes from clean outside source of supply in order to prevent damage to the packing and shaft. In placing the packing, each packing ring should be cut to the proper length so that ends come together but don't overlap. The succeeding rings of packing should not be pressed too tight, as it may result in burning the packing and cutting the shaft. If the stuffing box is not properly packed, friction in stuffing box prevents turning the rotor by hand. On starting the pump it is well to have the packing slightly loose without causing an air leak, and if it seems to leak, instead of putting too much pressure on the gland, put some heavy oil in the stuffing box until the pump works properly and then gradually tighten up the gland. The packing should be occasionally changed.

BALL BEARINGS

Correct maintenance of ball bearings is essential. The bearing manufacturers give the following as a guide to re-lubrication periods under normal condition.

Three monthly when on continuous duty.
Six monthly when on eight hour per day duty.

The bearings and housings should be completely cleaned and recharged with fresh grease after 2500 hrs. or the nearest pump overhaul time.

PRIMING

No pumping action occurs unless the pump casing is filled with the liquid. Pump casing and suction pipe must therefore be completely filled with liquid and thus all air removed before the pump is started. Several different priming methods can be used depending on the kind of installation and service involved.

- 1) Liquid level above pump level.

Pump is set below liquid level of source of supply, so that liquid always flows to pump under positive head.

2) Priming with foot-valve.

a. When pump is installed on suction lift with foot valve at the end of suction line, fill pump with water from some outside source till all air is expelled and water flows through the air vent.

b. When there is liquid under some pressure in the discharge pipe, priming can be effected by bypassing the pressured liquid around the check and gate valve. Of course, the initial priming must be affected from some outside source.

Note: In this case, the foot-valve must be capable of withstanding pump pressure and possible surge.

Priming by ejector

An ejector operated by steam, compressed air or water under pressure and connected to air vent at the top of casing can be used to remove air from pump and prime the pump on suction lift installations.

Priming by dry vacuum pump

A hand or power pump sucks in all the air from the casing and the suction pipe, and thus primes the system.

STARTING

The pump must not be started without being primed. Be sure that the driver rotates in the proper direction as indicated by a direction arrow on the pump casing.

RUNNING

On account of its simple construction, the centrifugal pump requires practically no attention while running. Lubrication at the bearings and manipulation of the glands are the only things that need attention from the operator.

STOPPING

Before stopping the pump; close the gate valve. This will prevent water hammer on the check valve.

STUFFING BOXES (only for gland packed pump)

Do not tighten the glands excessively. A slight dipping of water from the stuffing boxes when pump is running keeps packing in good condition.

CASING RINGS

Casing rings are fitted in the casing to reduce the quantity of water leaking back from the high pressure side to the suction side. These casing rings are fitted to maintain a small clearance and depend on the water in the pump for lubrication. When the rings are worn out, the clearance becomes greater and more water passes back into the suction side. The rings must be replaced from time to time to restore the pump efficiency to its normal value.

SPARE PARTS

A set of ball bearings, a set of casing rings and a set of gland packing rings / mechanical seal must always be kept at hand to ensure uninterrupted service from the pump. While ordering for spare parts, always give type, size and serial number of the pump as stamped on the number plate.

PUMP TROUBLE

When investigating trouble with Kirloskar pumps, always remember that pumps have been tested at the factory and are mechanically correct when sent out. Discounting the possibility of damage during transit, most of the trouble in the field is due to faulty installation. Investigation shows that the majority of troubles with centrifugal pumps result from faulty conditions on the suction side.

BREAK DOWN-CAUSE-CHECK POINTS

In case of breakdown we recommend the location of the fault by using the following table.

BREAKDOWN CHECK POINTS

CHECK POINTS

1. Suction pipe, foot valve choked.
2. Nominal diameter of suction line too small.
3. Suction pipe not sufficiently submerged.
4. Too many bends in the suction line.
5. Clearance around suction inlet not sufficient.
6. Shut off valve in the suction line in unfavorable position.
7. Incorrect layout of suction line (formation of air pockets).
8. Valve in the suction line not fully open.
9. Joints in the suction line not leak-proof.
10. Air leaking through the suction line and stuffing box etc.
11. Suction lift too high.
12. Suction head too low (difference between pressure at suction connection and vapor pressure too low).
13. Delivery liquid contains too much gas and/or air.
14. Delivery liquid too viscous.
15. Insufficient venting.
16. Number of revolutions too high.
17. Number of revolutions too low.
18. Incorrect direction of rotation (electric motor incorrectly connected, leads of phases on the terminal block interchanged).
19. Impeller clogged.
20. Impeller damaged.
21. Casing rings worn out.
22. Separation of crystals from the flow of pumping liquid (falling below the temperature limit/equilibrium temp).
23. Connection line from stuffing box to casing obstructed.
24. Fluid arrester not suitable for operating conditions.
25. Shaft sleeve worn in the region of the Fluid arrester.
26. Bearings worn out.
27. Ball bearings incorrectly fitted.
28. Axial stress on ball bearings (no axial clearance for rotor).
29. Axial thrust too great because of worn casing rings, relief holes obstructed.
30. Alignment of coupling faulty or coupling loose.
31. Elastic element of coupling worn.
32. Pump casing under stress.
33. Pipeline under stress.
34. Shaft runs untrue.
35. Shaft bent.
36. Rotor parts insufficiently balanced.
37. Rotor parts touching the casing.
38. Vibration of pipe work.
39. Non-return valve gets caught.
40. Contaminated delivery liquid.
41. Obstruction in delivery line.
42. Delivery flow too great.
43. Pump unsuitable for parallel operation.
44. Type of pump unsuitable.
45. Incorrect choice of pump for existing operating conditions.
46. Voltage too low/power supply overloaded.
47. Short circuit in the motor.
48. Setting of starter of motor too high.
49. Temperature delivery liquid too high.

Pump does not deliver	1 7 8 9 10 11 12 14 15 17 18 19 43 44 45
Pump delivers at reduced capacity	1 2 3 4 5 6 7 8 9 10 11 12 13 14 15 17 18 19 20 21 22 43 44 45
Delivery performance deteriorates	1 3 7 9 10 11 12 13 14 19 20 21 22 40 44 49
Pump delivers too much	16 43 44 45
Delivery is interrupted	1 3 6 7 8 9 10 11 12 13 14 15 16 19 22 39 43 44 45 49
After stopping pump runs in reverse direction	39
Very noisy	1 2 5 6 7 8 11 12 13 15 19 20 22 41 42 43 44 49
Unsteady running of pump	19 20 22 26 27 28 29 30 31 34 35 36 37 38 41 42 45
Stuffing box leaks	23 24 25 26 34 35 36 40
Fumes from stuffing box	22 23 24 25 30
Pump rotor locked in standstill position	22 32 33 37
Pump is heating up and seizing	23 24 25 29 32 34 35 36 37 41
Bearing temperature increases	19 20 21 22 26 27 28 29 30 31 32 33 34 35 36 38 41 42 45
Motor will not start	14 22 47
Motor gets hot or burns out	14 22 29 30 37 42 43 44 45 46 47 48
Motor is difficult to start	14 22 32 33 37 45 46 47