

# Valvcon™

V-Series electric actuators

115 VAC and 230 VAC

with Iso/Readback board installed  
(Option "U")

## Installation, maintenance and operating instructions

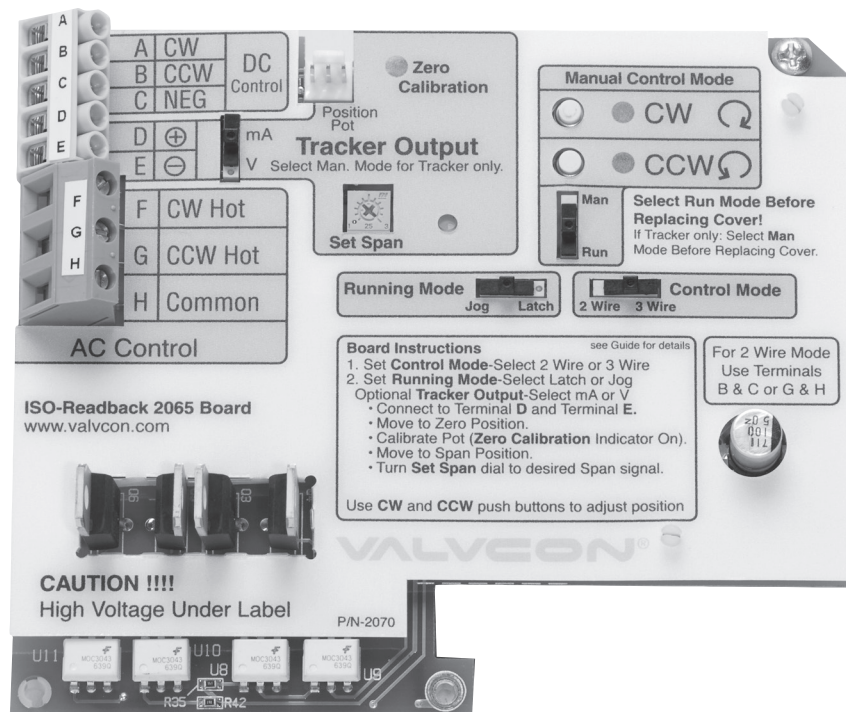

# Table of contents

<b>GENERAL</b>	<b>3</b>	<b>GENERAL OPERATING INFORMATION</b>	<b>10</b>
Scope of the Manual	3	Enclosure Ratings and Product Certifications	10
Actuator Markings	3	Wiring	10
Safety Precautions	3	Duty Cycle and Motor Protection	10
<b>TRANSPORTATION AND STORAGE</b>	<b>3</b>	Operating Temperature Limits	10
<b>GENERAL INSTALLATION INFORMATION</b>	<b>3</b>	Actuator Mounting	11
Description of Iso/Readback Board	3	Manual Override	11
Operation	4	Lubrication	11
Operation for ON/OFF or Jogging Applications (Motor Board only)	6	Problem Prevention	11
Board Installation	7	Warranty	11
Tools Required	7	Repair Service/Spare Parts	11
<b>V-SERIES STANDARD OPTIONS</b>	<b>8</b>	<b>SPECIFICATIONS &amp; TECHNICAL INFORMATION</b>	<b>12</b>
Option "H" – Tropical Heater and Thermostat P/N VC099716, VC099723	8	Dimensions	13
Option Codes "I1", "I2", "I3", and "I4" - ISO 5211 Metric Output	9	Exploded View	14
Option "K" – Mechanical Brake P/N VC099715	9	<b>V-SERIES ACTUATORS BY MODEL NUMBER</b>	<b>15</b>
Option "P" – Feedback Potentiometer P/N VC099200	9	<b>DECLARATION OF CONFORMITY</b>	<b>16</b>
Option "S2" – Two Auxiliary Limit Switches P/N VC099000	9	<b>ADDITIONAL ACTUATOR PRODUCTS AND ACCESSORIES FROM NELES</b>	<b>17</b>
Option "T" – Heater and Thermostat P/N VC099515, P/N VC099523	9		
Option Codes "Y1", "Y2", and "Y3" - Keyed Output	10		
Option "Z" – Handwheel Override P/N VC009097, P/N VC009098	10		
Voltage	10		

**READ THESE INSTRUCTIONS FIRST!**

These instructions provide information about safe handling and operation of the valve.

If you require additional assistance, please contact the manufacturer or manufacturer's representative.

**SAVE THESE INSTRUCTIONS!**

Addresses and phone numbers are printed on the back cover.

# 1. GENERAL

## 1.1 SCOPE OF THE MANUAL

This instruction manual contains important information regarding the installation, operation and maintenance of the Valvcon™ V-Series electric actuator. Please read these instructions carefully and save them for future reference.

## 1.2 ACTUATOR MARKINGS

### WARNING

AS THE USE OF THE ACTUATOR IS APPLICATION SPECIFIC, A NUMBER OF FACTORS SHOULD BE TAKEN INTO ACCOUNT WHEN SELECTING AN ACTUATOR FOR A GIVEN APPLICATION. THEREFORE, SOME OF THE SITUATIONS IN WHICH THE ACTUATORS ARE USED ARE OUTSIDE THE SCOPE OF THIS MANUAL.

IF YOU HAVE ANY QUESTIONS CONCERNING THE USE, APPLICATION OR COMPATIBILITY OF THE ACTUATOR WITH THE INTENDED SERVICE, CONTACT NELES FOR MORE INFORMATION.

The actuator has an identification nameplate label attached to the base casting (see **Figure 1**).

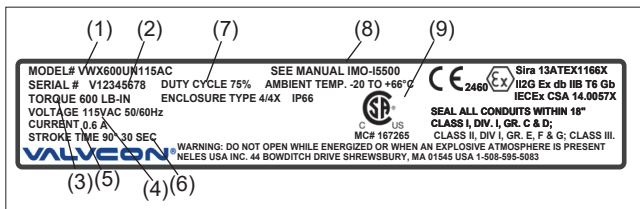

Figure 1. Identification nameplate label

Identification nameplate label markings:

1. Model number
2. Serial number
3. Maximum output torque
4. Voltage
5. Current draw (full-load running)
6. Cycle time
7. Duty cycle
8. Applicable manual
9. Certifications marking

## 1.3 SAFETY PRECAUTIONS

### WARNING

DO NOT EXCEED THE ACTUATOR PERFORMANCE LIMITATIONS!  
EXCEEDING THE TORQUE LIMITATIONS MARKED ON THE ACTUATOR IDENTIFICATION NAMEPLATE LABEL MAY CAUSE DAMAGE TO THE ACTUATOR AND/OR FINAL DRIVE ELEMENT.

### WARNING

WHENEVER WORKING INSIDE THE ACTUATOR, CARE MUST BE TAKEN TO AVOID DAMAGE TO THE MACHINED FLANGE SURFACES ON THE COVER AND BASE CASTINGS. FAILURE TO DO SO CAN VOID THE ACTUATOR'S ENVIRONMENTAL CERTIFICATION.

### WARNING

DO NOT EXCEED THE ACTUATOR ELECTRICAL LIMITATIONS!

EXCEEDING THE ELECTRICAL LIMITATIONS MARKED ON THE ACTUATOR IDENTIFICATION NAMEPLATE LABEL MAY CAUSE DAMAGE TO THE ACTUATOR AND/OR PERSONAL INJURY.

### WARNING

BEWARE OF MOVEMENT OF THE FINAL DRIVE ELEMENT AND ANY LINKAGE BETWEEN IT AND THE ACTUATOR!

KEEP HANDS, OTHER PARTS OF THE BODY, TOOLS AND OTHER OBJECTS OUT OF THE WAY OF MOVING PARTS. FAILURE TO DO THIS MAY RESULT IN DAMAGE OR PERSONAL INJURY!

# 2. TRANSPORTATION AND STORAGE

Check the actuator and any accompanying devices for any damage that may have occurred during transport.

Store the actuator carefully. Storage indoors in a dry place is recommended.

Move the actuator to its intended location just before installation.

The actuator is usually shipped in the full clockwise, (typically closed) position.

If the actuator(s) will be stored for a period longer than 90 days, follow the recommendations in IMO-S2 to maintain the actuator's integrity.

# 3. GENERAL INSTALLATION INFORMATION

## 3.1 DESCRIPTION OF ISO/ READBACK BOARD

The V-Series Iso/Readback Board is a 115/230 VAC option that provides jogging or latching control from a low voltage (12 VDC or 24 VDC) or high voltage (115 VAC or 230 VAC) control signal. It also provides:

- a 4-20 mA or 0-10 DC position "readback" signal
- isolation for the motor, so that multiple actuators may be wired in parallel
- supervisory control via a mode selector switch and on-board CW and CCW push buttons. The supervisory control mode overrides a remote signal for simple and uninterrupted system set-up.

The isolation feature solves the problem of feedback voltage interfering with PLC or DCS systems. In standard electric actuators, the motor acts as an inductive load and "steps up" the input voltage, and feeds it back via the non-powered terminals to the power supply. The Iso/Readback board isolates the motor from the control signal, preventing the feedback voltage from reaching the power supply.

**WARNING**

USE CARE WHENEVER WORKING WITH THE ACTUATOR COVER REMOVED. DAMAGE, SCRATCHES, OR DENTS ON THE MACHINED FLANGE SURFACES OF THE ENCLOSURE MAY VOID COMPLIANCE WITH NEMA, CSA, UL, AND/OR IEC SPECIFICATIONS. (SEE SECTION 3.3.3) FLAMEPROOF JOINTS ARE NOT INTENDED TO BE REPAIRED.

Position indication is available at terminals 5 and 6 on the Motor Board (for discrete end of travel indication), and at terminals D and E on the Iso/Readback Board (for analog position readback).

**NOTE:** This option will fit all V-Series 115 & 230 VAC actuators with the letter "N" preceding the voltage designator in the part number on the product nameplate.

**WARNING**

DANGEROUS VOLTAGES ARE PRESENT INSIDE THE ACTUATOR COVER UNLESS THE POWER SUPPLY TO THE ACTUATOR HAS BEEN SHUT OFF OR DISCONNECTED. USE EXTREME CAUTION WHENEVER WORKING ON THE ACTUATOR WITH THE COVER REMOVED.

**WARNING**

ACTUATORS SHOULD BE PROPERLY GROUNDED AND WIRED IN ACCORDANCE WITH LOCAL ELECTRICAL CODE; SEE IDENTIFICATION NAMEPLATE LABEL FOR MAXIMUM CURRENT DRAW.

### 3.2 OPERATION

**WARNING**

WHENEVER WORKING INSIDE THE ACTUATOR, CARE MUST BE TAKEN TO AVOID DAMAGE TO THE MACHINED FLANGE SURFACES ON THE COVER AND BASE CASTINGS. FAILURE TO DO SO CAN VOID THE ACTUATOR'S ENVIRONMENTAL CERTIFICATION.

**NOTE:** Assumes option is installed; if installing kit, see Section 3.4 of this manual.

#### HIGH OR LOW VOLTAGE CONTROL SIGNAL

The Iso/Readback Board plugs into the Valvcon™ Motor Board using standard brackets and mounting screws provided. Several selector switches are provided on the board for mode set-up. The matrix below explains the actuator's functions for each combination of switch settings:

### POSITION READBACK

The Iso/Readback Board provides either a 4-20 mA or 0-10 VDC analog signal for position indication. To initiate this function, connect to terminals D and E on the Iso/Readback Board. Then:

1. Calibrate the Zero position (4 mA or 0 VDC) by selecting the "Man" mode and use the on-board CW push button to drive to the full clockwise position. Using the 1/16" Allen wrench provided, loosen the setscrew on the larger, white nylon gear. Adjust that gear until the "Zero Calibration" LED turns on. Tighten the setscrew.

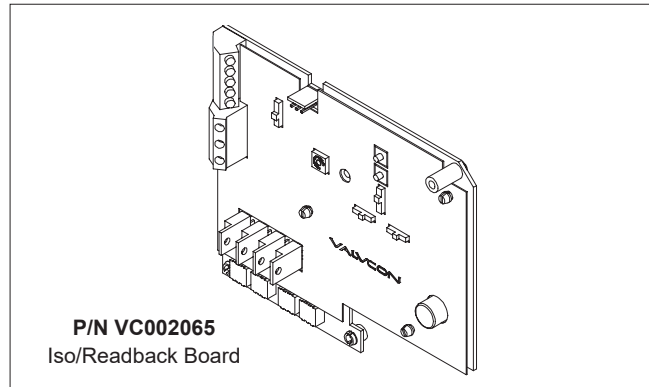

Figure 2.

2. Calibrate the Span position by using the on-board CCW push button to drive to the full counter-clockwise position. Adjust the "Set Span" potentiometer until you read the desired Span signal (20 mA or 10 VDC).
3. If you are using the Position Readback signal in conjunction with a high or low voltage control signal, return the selector switch to the "Run" mode.
- 3a. If you are using the Position Readback signal without the high or low voltage control signal, leave the selector switch in the "Man" position.

TABLE 1	
Selector Switch Modes	
Control	Running
2 Wire	<b>Jog</b> When the control signal is maintained at terminals B and C (DC voltage) or G and H (AC voltage), the actuator will drive to the full counter-clockwise position When the control signal is de-energized, the actuator will drive to the full clockwise position.
	<b>Latch</b> When 2 Wire Mode is selected, the Running Mode must be set to "Jog".
3 Wire	<b>Jog</b> When the control signal is maintained at terminals B and C (DC voltage) or G and H (AC voltage), the actuator will drive to the full counter-clockwise position When the control signal is maintained at terminals A and C (DC voltage) or F and H (AC voltage), the actuator will drive to the full clockwise position When the control signal is de-energized, the actuator will remain in position.
	<b>Latch</b> When a momentary control signal is applied to terminals B and C (DC voltage) or G and H (AC voltage), the actuator will drive to the full counter-clockwise position When a momentary control signal is applied to terminals A and C (DC voltage) or F and H (AC voltage), the actuator will drive to the full clockwise position.

## Wiring Diagram – Three Wire Mode

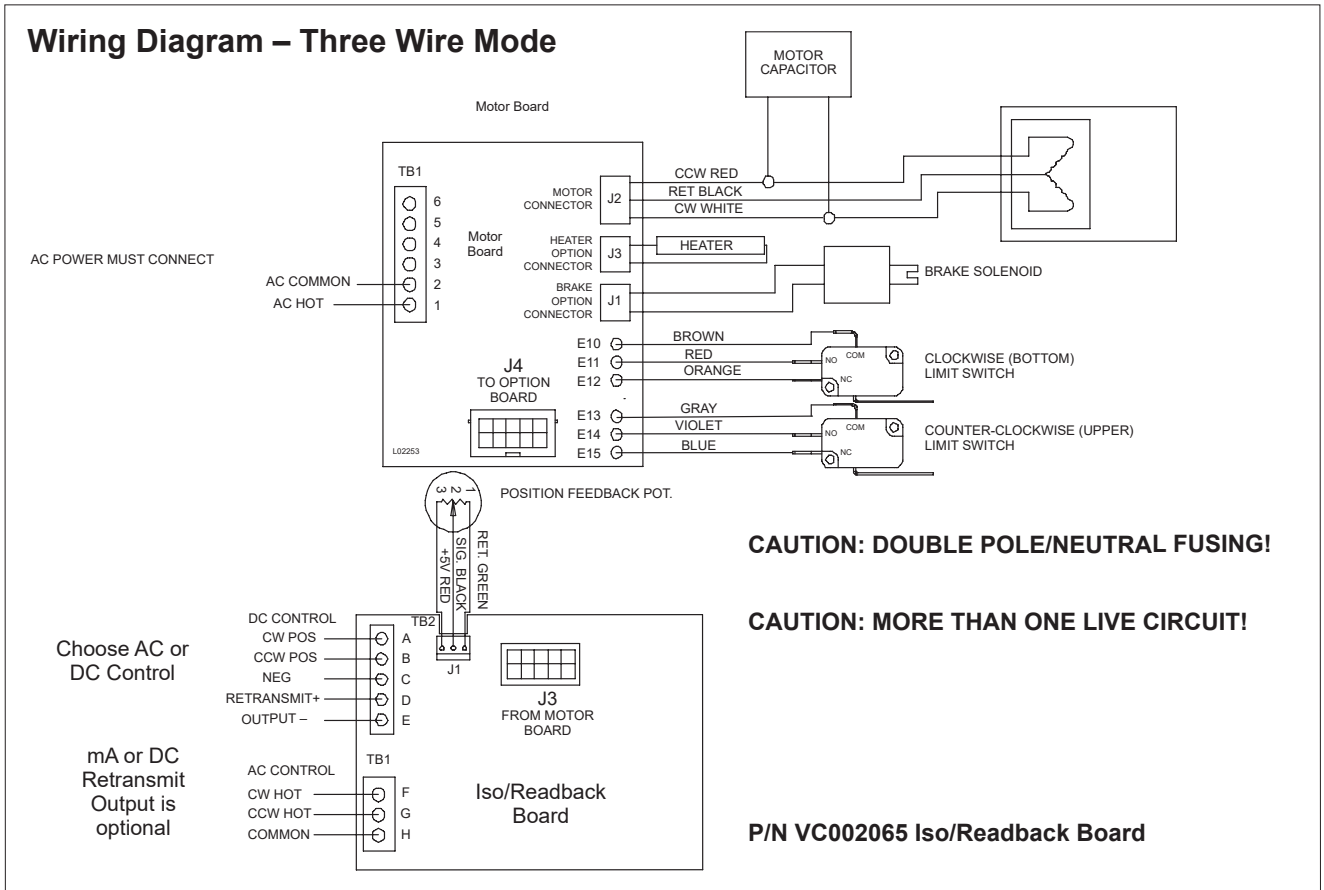

Figure 3.

## Wiring Diagram – Two Wire Mode

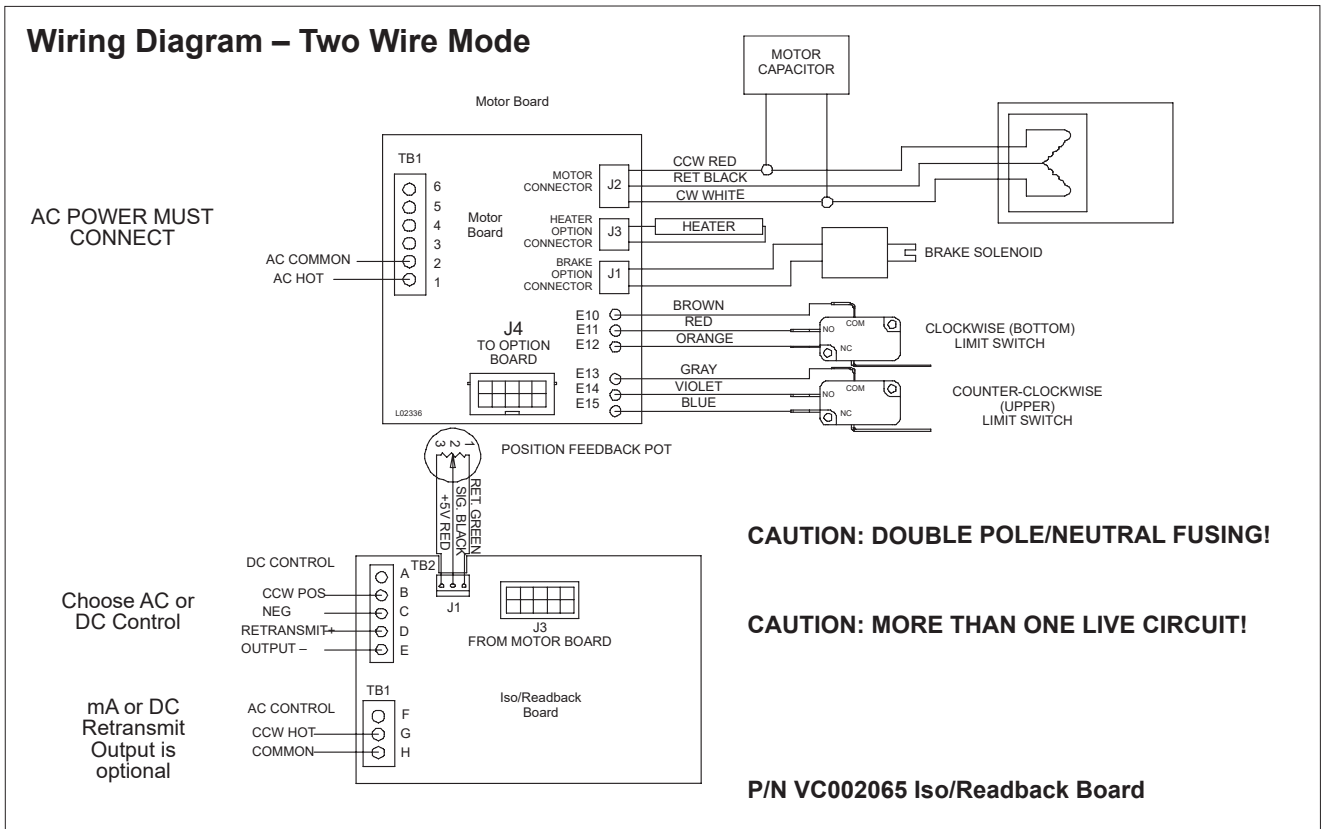

Figure 4.

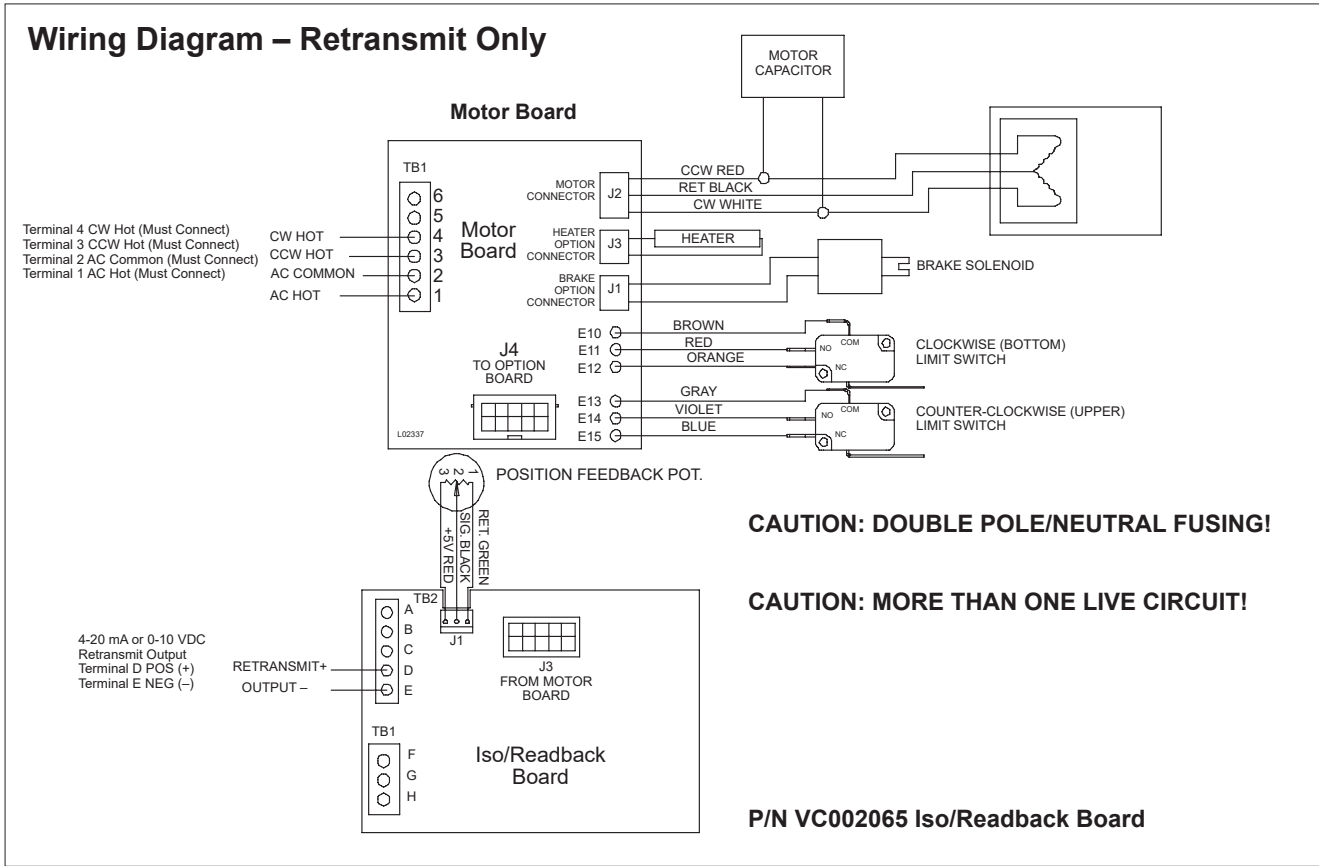

Figure 5.

### 3.3 OPERATION FOR ON/OFF OR JOGGING APPLICATIONS (MOTOR BOARD ONLY)

**WARNING**

VALVCON™ AC VOLTAGE ACTUATORS USE REVERSING INDUCTION MOTORS WHICH CAUSE HIGH VOLTAGES. **DEVICES CONNECTED TO TERMINAL 3 AND TO TERMINAL 4 MUST BE RATED FOR MINIMUM 250 VAC** (440 VAC FOR 230 VAC APPLICATIONS). DUE TO THE INDUCED FEEDBACK VOLTAGE, MULTIPLE ACTUATORS CANNOT BE WIRED IN PARALLEL. SEPARATE (ISOLATED) CONTACTS MUST BE PROVIDED FOR EACH ACTUATOR.

**WARNING**

WHENEVER WORKING INSIDE THE ACTUATOR, CARE MUST BE TAKEN TO AVOID DAMAGE TO THE MACHINED FLANGE SURFACES ON THE COVER AND BASE CASTINGS. FAILURE TO DO SO CAN VOID THE ACTUATOR'S ENVIRONMENTAL CERTIFICATION.

#### SET UP FOR OPERATION

Two limit switches operated by the cams on the output shaft determine the exact positions where the actuator will stop at each end of travel. The bottom limit switch determines the clockwise stop

position. The next limit switch up from the bottom determines the counter-clockwise stop position. The end of travel limit switches can be adjusted to provide from 5 to 320 degrees of actuator rotation.

The two standard limit switches may be used to indicate the open and closed status of the actuator. Terminals 5 (counter-clockwise) and 6 (clockwise) provide the position indication at line voltage. If dry contacts or intermediate position indication are needed, additional limit switches and cams may be installed in the actuator. When additional limit switches are installed, they can be set in any position and are wired to a separate terminal block provided with the option. See **(Section 4), V-Series Standard Options**.

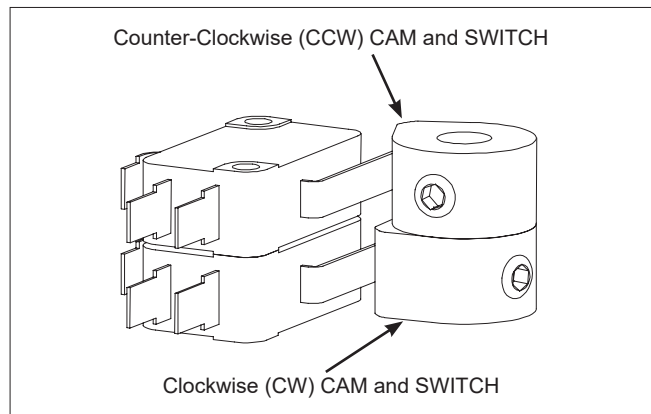

Figure 6.

## SETTING ACTUATOR STOP POSITIONS

### WARNING

DANGEROUS VOLTAGES ARE PRESENT INSIDE THE ACTUATOR COVER UNLESS THE POWER SUPPLY TO THE ACTUATOR HAS BEEN SHUT OFF OR DISCONNECTED. USE EXTREME CAUTION WHENEVER WORKING ON THE ACTUATOR WITH THE COVER REMOVED.

**NOTE:** To gain more access to cams, move the capacitor and terminal strip, if installed.

1. Loosen the set screw in the cam using a 1/16" hex wrench. The bottom cam controls the clockwise end-of-travel, and the second cam, (from the bottom) controls the counter-clockwise end-of-tavel (See Figure 3).
2. Move the actuator to the desired STOP position
3. Apply power according to desired mode of operation or use the manual override. (See Figures 4, 5 & 6)
4. Remove the power and rotate cam in the direction of travel to the exact point the switch "clicks" closed.
5. Tighten the set screw.
6. Repeat this procedure to set the opposite end of the travel limit.

**NOTE:** For actuators including hazardous location certification. Prior to installing cover, inspect machined flange surfaces for any damage, scratches, or dents. Damage, scratches, or dents that will not fit completely in a circle having a diameter of 1/64" will void hazardous location certifications. If such imperfections are present the damaged enclosure parts(s) must be replaced. See Table 2 for captive cover screw specifications. Consult the factory for replacement parts.

## PROPER ACTUATOR COVER INSTALLATION

1. Remove the override shaft from the actuator cover bushing; if the actuator is equipped with a handwheel, remove the handwheel before removing the top piece of the "two-piece" shaft form the cover bushing.
2. Install the override shaft on the square motor shaft; if the actuator is equipped with a handwheel, install the bottom piece of the "two-piece" shaft on the motor shaft and then install the top piece of the shaft onto the bottom piece of the shaft.
3. Align cover so that the override shaft will pass through the override bushing and carefully push it down so that the cover flange contacts the base flange.
4. Once the cover is properly seated, tighten the screws to secure the cover; a cross pattern is recommended for uniform distribution of load.
5. If the position indicator is not seated to the output/cam shaft, turn until it drops into place in order to ensure accurate visual position indication.

## 3.4 BOARD INSTALLATION

### WARNING

DANGEROUS VOLTAGES ARE PRESENT INSIDE THE ACTUATOR COVER UNLESS THE POWER SUPPLY TO THE ACTUATOR HAS BEEN SHUT OFF OR DISCONNECTED. USE EXTREME CAUTION WHENEVER WORKING ON THE ACTUATOR WITH THE COVER REMOVED.

## 3.5 TOOLS REQUIRED

- 1/16" Hex wrench
- #1 or #0 Philips Screwdriver
- 1/2" Wrench/Nut driver

## INSTALLATION INSTRUCTIONS !DISCONNECT POWER!

1. Remove and discard screw that secures Motor Board to the upper bracket. (See Figure 9).
2. Remove 1/2" nut and lockwasher from potentiometer (Pot) shaft and insert, "Pot shaft up" through hole in upper support bracket. Align lockwasher and nut and tighten.
3. Plug Pot connector into the 3-pin connector on the front of the Iso/Readback Board ("J1"). Plug Iso/Readback Board into Motor Board (P/N VC002015) via 10-pin connector and secure to the existing bracket with three mounting screws. (See Figure 7).

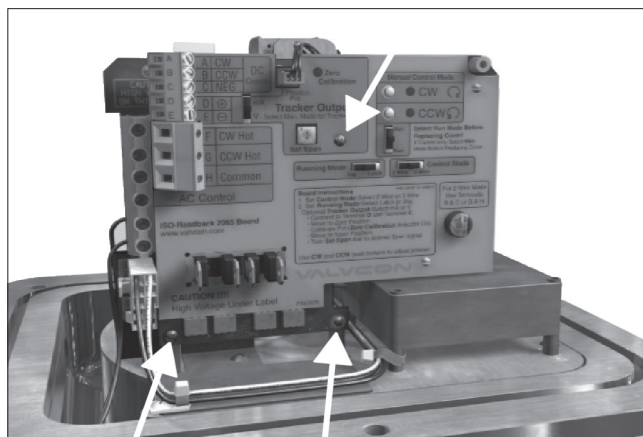

Figure 7.

4. Place small (20-tooth) gear on Pot shaft and tighten. Place spacer on Camshaft then place large (60-tooth) gear on Camshaft. Properly positioned, gears should mesh evenly. (See Figure 8).

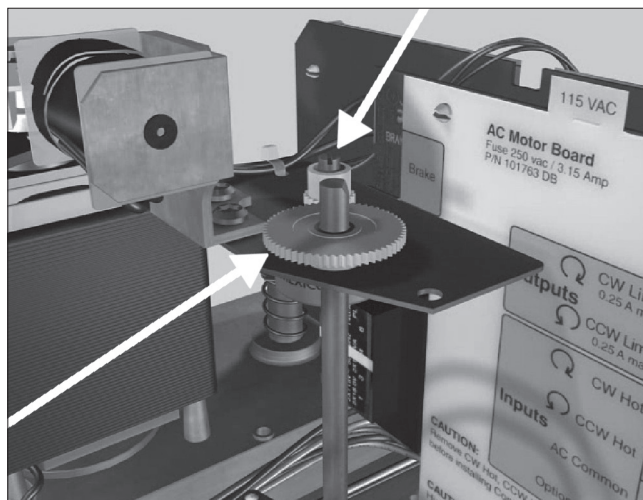

Figure 8.

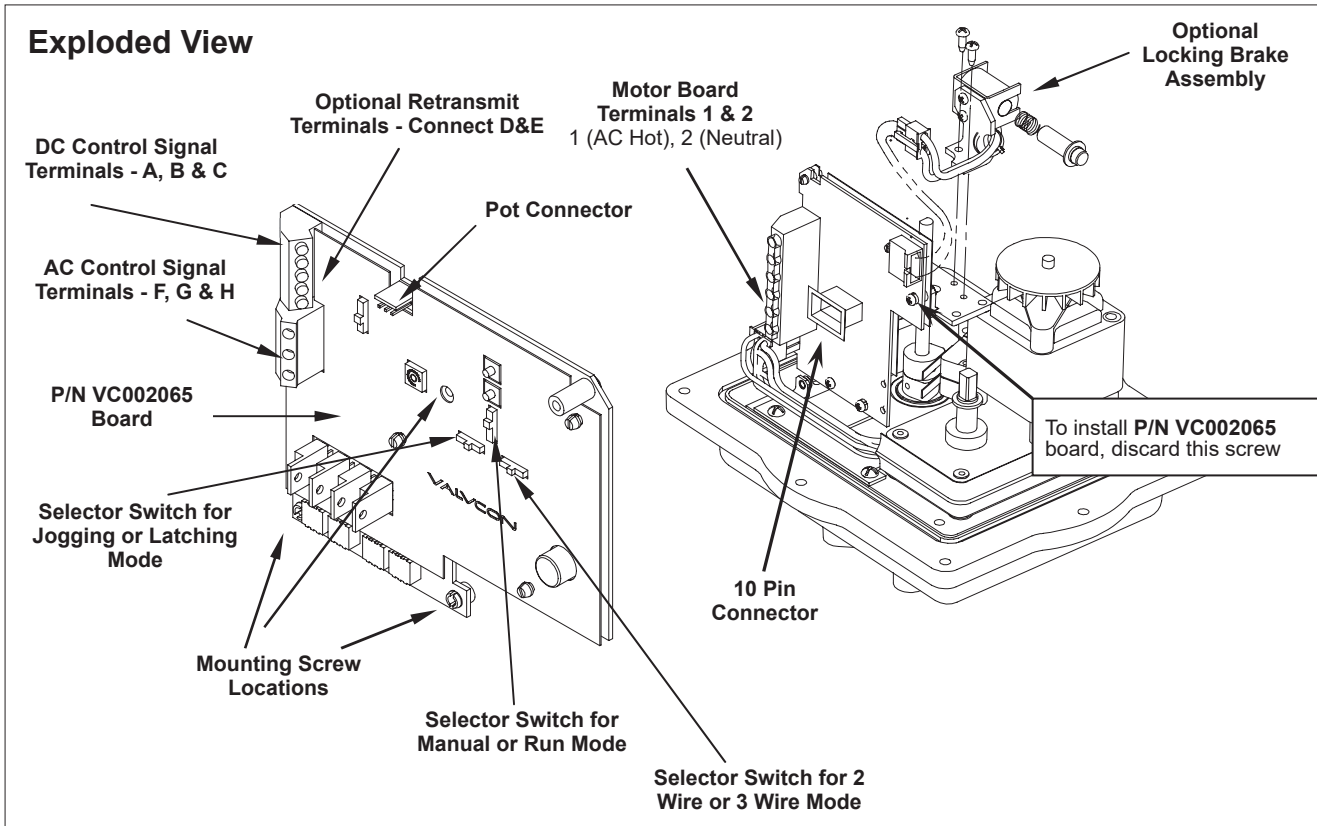

Figure 9.

5. Loosen setscrew in CW or CCW cam. (1/16 hex wrench)  
 CW = bottom cam  
 CCW = next cam up from bottom cam
6. Connect AC Power to terminal 1 (Hot) and 2 (Common) of Motor Board **P/N VC002015**. Select Manual Mode and drive to desired STOP position. Remove power.
7. Rotate cam in the direction of travel to the exact point that the switch “clicks” open. Tighten setscrew
8. Repeat procedure 5, 6 and 7 to set opposite end of travel limit.
9. Connect AC or DC Control Signals to AC or DC Control terminals to achieve desired operation, as indicated in wiring diagrams on previous pages.

## 4. V-SERIES STANDARD OPTIONS

All V-Series options are designed to be easily installed in the field. Options for all standard V-Series actuators are universal and completely interchangeable with each enclosure size. For additional V-Series Options, see **(Table 3)**. Voltage is not field changeable.

### 4.1 OPTION “H” – TROPICAL HEATER AND THERMOSTAT P/N VC099716, VC099723

The tropical heater and thermostat option is a self-adhesive, resistance heater strip which is applied to the primary gearbox. It installs with a plug-in connector and is recommended in

high-humidity applications. The tropical heater option is also recommended in installations that experience wide temperature swings in order to evaporate any condensation. Thermostat is pre-set to activate at or below 90°F (32°C) and deactivate at or above 110°F (43°C). The tropical heater draws 15 watts at 115 VAC; 40 watts at 230 VAC (see IMO-I9500 for additional reference).

#### WARNING

WHENEVER WORKING INSIDE THE ACTUATOR BE SURE TO FOLLOW ALL GUIDELINES, AND HEED ALL WARNINGS IN THIS MANUAL. IF INSTALLING AN OPTION KIT, BE SURE TO READ AND FOLLOW THE SUPPLIED INSTRUCTIONS CAREFULLY AND HEED ANY ADDITIONAL WARNINGS

This option can be installed in the field; for 115 VAC applications, order kit **P/N VC099716** and for 230 VAC applications, order kit **P/N VC099723**.

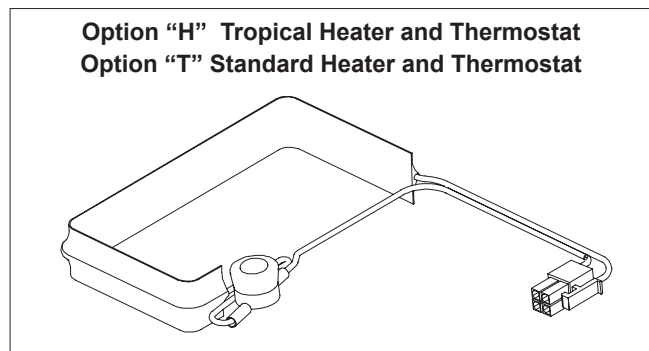

Figure 10.



## 4.2 OPTION CODES “I1”, “I2”, “I3”, AND “I4” - ISO 5211 METRIC OUTPUT

The actuator is equipped with an ISO 5211 compliant mounting configuration. The standard drive output for 150-600 lb-in models is a 3/4" female square. The standard drive output for 1000-3000 lb-in models is a 1" female square. We offer several female keyed drive output options, consult the “How to Order” section for available sizes for a given actuator model.

This option is factory installed only.

## 4.3 OPTION “K” – MECHANICAL BRAKE P/N VC099715

The brake option prevents back-driving; it is required on all butterfly valve and damper applications. It is also recommended on PVC ball valves and resilient seated valves. The brake option draws 4 watts and is universal to all standard V-Series actuators. It is simple to install with a plug-in connector and two philips head mounting screws. No additional brackets are required.

### WARNING

WHENEVER WORKING INSIDE THE ACTUATOR BE SURE TO FOLLOW ALL GUIDELINES, AND HEED ALL WARNINGS IN THIS MANUAL. IF INSTALLING AN OPTION KIT, BE SURE TO READ AND FOLLOW THE SUPPLIED INSTRUCTIONS CAREFULLY AND HEED ANY ADDITIONAL WARNINGS.

This option can be installed in the field; order kit **P/N VC099715**.

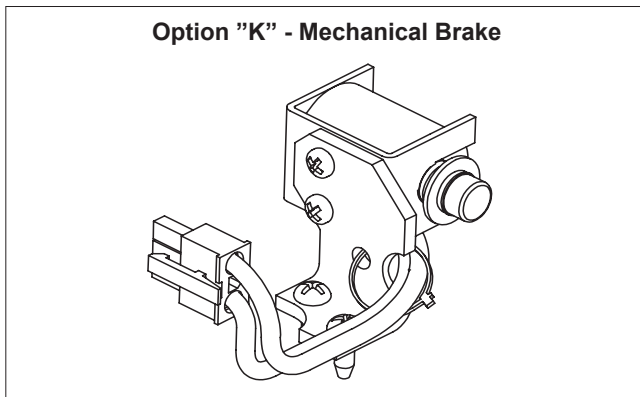

Figure 11.

## 4.4 OPTION “P” – FEEDBACK POTENTIOMETER P/N VC099200

The Feedback Potentiometer option provides 0 – 1000 Ohm resistance feedback and includes a 12-position terminal block for internal wiring (see IMO-I9200 for additional reference).

### WARNING

WHENEVER WORKING INSIDE THE ACTUATOR BE SURE TO FOLLOW ALL GUIDELINES, AND HEED ALL WARNINGS IN THIS MANUAL. IF INSTALLING AN OPTION KIT, BE SURE TO READ AND FOLLOW THE SUPPLIED INSTRUCTIONS CAREFULLY AND HEED ANY ADDITIONAL WARNINGS

This option can be installed in the field; order kit **P/N VC099200**.

## 4.5 OPTION “S2” – TWO AUXILIARY LIMIT SWITCHES P/N VC099000

The extra switches and stainless steel cams provide dry contacts and are fully adjustable to trip at any position. They are often used for position indication or to interlock other devices (such as in sequencing operations). The switches are single pole, double throw switches rated for 1/2 HP, 11 amps at 250 VAC, CSA certified. Auxiliary switch kit P/N VC099000 is universal to all standard V-Series actuators and includes “flying wiring leads” for termination inside of the actuator enclosure using the supplied 6-position terminal block.

### WARNING

WHENEVER WORKING INSIDE THE ACTUATOR BE SURE TO FOLLOW ALL GUIDELINES, AND HEED ALL WARNINGS IN THIS MANUAL. IF INSTALLING AN OPTION KIT, BE SURE TO READ AND FOLLOW THE SUPPLIED INSTRUCTIONS CAREFULLY AND HEED ANY ADDITIONAL WARNINGS.

This option can be installed in the field; order kit **P/N VC099000**.

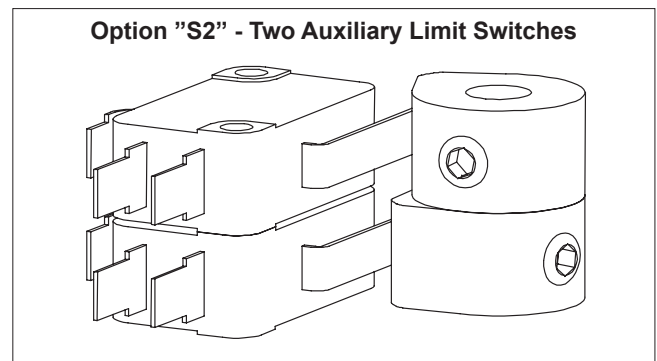

Figure 12.

## 4.6 OPTION “T” – HEATER AND THERMOSTAT P/N VC099515, P/N VC099523

The heater and thermostat option is a self-adhesive, resistance heater strip which is applied to the primary gearbox. It installs with a plug-in connector and is recommended in installations where the ambient temperatures drop below 32°F (0°C). Thermostat is pre-set to activate at or below 40°F (4°C) and deactivate at or above 60°F (15°C). The heater draws 15 watts at 115 VAC; 40 watts at 230 VAC (see IMO-I9500 for additional reference).

#### WARNING

WHENEVER WORKING INSIDE THE ACTUATOR BE SURE TO FOLLOW ALL GUIDELINES, AND HEED ALL WARNINGS IN THIS MANUAL. IF INSTALLING AN OPTION KIT, BE SURE TO READ AND FOLLOW THE SUPPLIED INSTRUCTIONS CAREFULLY AND HEED ANY ADDITIONAL WARNINGS.

This option can be installed in the field; for 115 VAC applications, order kit **P/N VC099515** and for 230 VAC applications, order kit **P/N VC099523** (see **Figure 5**).

## 4.7 OPTION CODES “Y1”, “Y2”, AND “Y3” - KEYED OUTPUT

The actuator is equipped with an ISO 5211 compliant mounting configuration. The standard drive output for 150-600 lb-in models is a 3/4” female square. The standard drive output for 1000-3000 lb-in models is a 1” female square. We offer several female keyed drive output options, consult the “How to Order” section for available sizes for a given actuator model.

This option is factory installed only.

## 4.8 OPTION “Z” – HANDWHEEL OVERRIDE P/N VC009097, P/N VC009098

All V-Series actuators are supplied with a wrench-operated manual override shaft. If the Handwheel Override option is selected the shaft is replaced by a declutchable shaft and a six-inch handwheel (see IMO-I9090 for additional reference).

#### WARNING

WHENEVER WORKING INSIDE THE ACTUATOR BE SURE TO FOLLOW ALL GUIDELINES, AND HEED ALL WARNINGS IN THIS MANUAL. IF INSTALLING AN OPTION KIT, BE SURE TO READ AND FOLLOW THE SUPPLIED INSTRUCTIONS CAREFULLY AND HEED ANY ADDITIONAL WARNINGS

This option can be installed in the field; for 150 – 600 lb•in (12 - 25 lb•ft; 17 - 68 Nm) models order kit **P/N VC009097** and for 1000 – 3000 lb•in (83 - 250 lb•ft; 113 - 339 Nm) models order kit **P/N VC009098**.

## 4.9 VOLTAGE

115 VAC or 230 VAC. V-Series actuators are rated for full torque at +/- 10% of the nominal voltage at 60 Hz. **NOTE:** operation at 50 Hz will proportionally decrease the duty cycle and increase the cycle time. V-Series actuators are rated for a minimum of 75%\* duty cycle at 60 Hz at/below 104°F (40°C).

\* 55% duty cycle for 3000 lb•in actuators.

## 5. GENERAL OPERATING INFORMATION

For enclosure specifications and dimensions, see (**Tables 1-2 and Figure 13**).

### 5.1 ENCLOSURE RATINGS AND PRODUCT CERTIFICATIONS

Neles offers two versions of V-Series actuator enclosures: the “W” enclosure is weathertight, and the “WX” enclosure which is weathertight and explosion-proof.

### 5.2 WIRING

#### WARNING

VALVCON™ AC VOLTAGE ACTUATORS USE REVERSING INDUCTION MOTORS WHICH CAUSE HIGH VOLTAGES. **DEVICES CONNECTED TO TERMINAL 3 AND TO TERMINAL 4 MUST BE RATED FOR MINIMUM 250 VAC** (440 VAC FOR 230 VAC APPLICATIONS).

CONTROLLERS WITH SOLID STATE OUTPUTS MUST BE RATED FOR MORE THAN 250 VAC. WE STRONGLY RECOMMEND THAT RELAY OUTPUTS BE USED ON CONNECTED DEVICES. DUE TO THE INDUCTION FEEDBACK VOLTAGE, MULTIPLE ACTUATORS CAN NOT BE WIRED IN PARALLEL. SEPARATE (ISOLATED CONTACTS) MUST BE PROVIDED FOR EACH ACTUATOR. IF THE ACTUATOR IS DRIVEN BY CONTACTS ON A PC OR PLC, MAKE SURE THE CONTACTS HAVE THE PROPER RATINGS.

### 5.3 DUTY CYCLE AND MOTOR PROTECTION

V-Series actuators can operate continuously for up to 15 minutes at 104°F (40°C). After 15 minutes of continuous operation they are rated for 75% duty cycle operation at 104°F and for 30 starts per minute. Duty cycles decrease at temperatures in excess of 104°F. Duty cycle is the maximum proportion of “on” time and the minimum required “off” time to prevent thermal overloading. Actuators with cycle times of 30 seconds must rest at least 10 seconds between cycles. Higher temperature applications decrease duty cycle.

AC motors contain thermal overload protection. Exceeding the rated duty cycle may cause the thermal overload switch to temporarily remove power to the motor and cause it to stall. After the motor cools, the actuator will resume normal operation. The thermal protector is a safety device, designed for infrequent use. Constant tripping of the thermal overload protector may cause premature motor failure.

### 5.4 OPERATING TEMPERATURE LIMITS

V-Series actuators are designed to operate in ambient environments between -40°F (-40°C) and 150°F (65°C). In outdoor applications where ambient temperatures exceed 80°F, actuators should be shielded from direct sunlight. In applications with high

media temperatures, insulating blankets, heat shields and/or extended mounting shafts should be used to maintain ambient temperatures at the actuator within normal operating limits.

Heaters and thermostats are recommended for all outdoor applications and may also be used to dry condensation in high humidity environments.

## 5.5 ACTUATOR MOUNTING

The actuator may be mounted in any position including upside-down. It must be firmly secured to a direct mount flange or sturdy mounting bracket. A minimum of four bolts with lock washers should be used to secure the actuator to the bracket. Flexibility in the bracket is not allowed, and backlash, or “play”, in the coupling should be minimized. The actuator output shaft must be in line (centered) with the valve shaft to avoid side-loading the shaft. See (Figure 13) for output drive dimensions and mounting hardware specifications.

### WARNING

FAILURE TO USE MANUAL OVERRIDE PROPERLY COULD RESULT IN DAMAGE TO THE ACTUATOR GEARING. ENSURE THAT THE OVERRIDE IS FULLY DISENGAGED AND DO NOT USE EXCESSIVE FORCE WHEN MANUALLY POSITIONING ACTUATOR. DO NOT DRIVE THE ACTUATOR BEYOND THE TRAVEL LIMIT SETTINGS. FAILURE TO FOLLOW THESE INSTRUCTIONS COULD RESULT IN DAMAGE TO THE ACTUATOR AND/OR FINAL DRIVE ELEMENT.

## 5.6 MANUAL OVERRIDE

To use the manual override, push the override shaft down approximately 1/4 inch to disengage the motor from the gear train. Failure to disengage motor prior to turning override will cause damage to the actuator. While holding the shaft down, turn the shaft with a wrench or handle to the desired position. **NOTE:** The override shaft on actuators below 1000 lb•in must be rotated in the opposite direction of the desired direction of the output shaft. In actuators 1000 lb•in and above, the override and the output shaft turn in the same direction.

Do not drive the actuator beyond the limit switch settings; it is possible to damage installed options such as a feedback potentiometer. The manual override shaft must be returned to its fully upward position before the motor is re-engaged. Rotate the shaft slightly to align the spur gears until the shaft “springs” back to its re-engaged position. **NOTE:** The rotation direction of the output may not be the same as the rotation of the override shaft!

## 5.7 LUBRICATION

All rotating power train components are permanently lubricated with multi-purpose Lithium grease suitable for the operating temperature range of the actuator. Additional lubrication is not required in normal operation.

## 5.8 PROBLEM PREVENTION

Most actuator problems result from improper installation.

**Incorrect Wiring and Set Up** Make certain the actuator is wired correctly and travel stops are properly set before power is applied.

**Coupling, Alignment, and Mounting** Do not add extra torque! Make certain that the mounting arrangement is sturdy, centered, properly aligned, and that all mounting hardware is secure and properly tightened.

**Moisture** Replace the cover tightly and make certain conduit entry holes are sealed properly to prevent moisture infiltration.

## 5.9 WARRANTY

All V-Series actuators are backed by a 2-year warranty that covers materials and workmanship. The warranty expires 24 months from installation or 30 months from delivery; whichever comes first.

To request a Return Authorization for an actuator within the warranty period, please consult your local Neles distributor.

## 5.10 REPAIR SERVICE/SPARE PARTS

We recommend that electric actuators be directed to our Northeast Service Center for maintenance. The Service Center is equipped to provide rapid turn-around at reasonable cost and offer new product warranty with all reconditioned electric actuators.

For electric actuators outside of the warranty period, request a Return Authorization by calling the Northeast Service Center at (508) 595-5195; or by sending an e-mail to [valvconservice@neles.com](mailto:valvconservice@neles.com).

**NOTE:** When sending electric actuators to the Service Center for repair, do not disassemble them! The actuator should be relatively clean upon return. For further information on spare parts and service or assistance, visit our Web site at [www.neles.com/products/actuators/electric-actuators/](http://www.neles.com/products/actuators/electric-actuators/).

**NOTE:** When ordering spare parts, always include the following information:

- a. Actuator model number from the product nameplate.
- b. Serial number from the product nameplate.
- c. Part number and/or description of the part required.
- d. Required quantity.

## 6. SPECIFICATIONS & TECHNICAL INFORMATION

Table 1 - Torque & VA Ratings									
Torque Output (Breakaway)	Speed (seconds per 90° rotation)	Duty Cycle (at/below 104°F/40°C)	Duty Cycle (at max temp; 150°F/66°C)	VA Rating		Max Running Current at Full Load (True RMS)		Max Effective Peak Inrush Current (= .66 x Peak rush)	
150 lb-in; 12 lb-ft; 17 Nm	8	75%; 8 sec ON, 3 sec OFF	50%; 8 sec ON, 8 sec OFF	70vA	115vA	0.6 amps	0.5 amps	1.25 amps	0.924 amps
300 lb-in; 25 lb-ft; 34 Nm	15	75%; 15 sec ON, 5 sec OFF	50%; 15 sec ON, 15 sec OFF	70vA	115vA	0.6 amps	0.5 amps	1.25 amps	0.924 amps
600 lb-in; 50 lb-ft; 68 Nm	30	75%; 30 sec ON, 10 sec OFF	50%; 30 sec ON, 30 sec OFF	70vA	115vA	0.6 amps	0.5 amps	1.25 amps	0.924 amps
1000 lb-in; 83 lb-ft; 113 Nm	25	75%; 25 sec ON, 9 sec OFF	50%; 25 sec ON, 25 sec OFF	92vA	161vA	0.8 amps	0.7 amps	1.66 amps	1.29 amps
1500 lb-in; 125 lb-ft; 169 Nm	40	75%; 40 sec ON, 14 sec OFF	50%; 40 sec ON, 40 sec OFF	92vA	161vA	0.8 amps	0.7 amps	1.66 amps	1.29 amps
2000 lb-in; 167 lb-ft; 226 Nm	55	75%; 55 sec ON, 19 sec OFF	50%; 55 sec ON, 55 sec OFF	92vA	161vA	0.8 amps	0.7 amps	1.66 amps	1.29 amps
2500 lb-in; 208 lb-ft; 282 Nm	70	75%; 70 sec ON, 24 sec OFF	35%; 70 sec ON, 130 sec OFF	92vA	161vA	0.8 amps	0.7 amps	1.66 amps	1.29 amps
3000 lb-in; 250 lb-ft; 339 Nm	75	55%; 75 sec ON, 62 sec OFF	25%; 75 sec ON, 225 sec OFF	92vA	161vA	0.8 amps	0.7 amps	1.66 amps	1.29 amps

Table 2 - Specifications	
<b>Temperature Range</b>	-40°F to 150°F (-40°C to 66°C); ATEX Temperature rating -20°C to 66°C
<b>Conduit Connections</b>	(2) 3/4" NPT all sizes (3/4" to 1/2" reducing bushings included)
<b>Output</b>	150 to 600 in-lbs: ISO 5211 F05 and F07 bolt circles, 3/4" female square; see "Dimensions" section and "How to Order " table for additional output options. 1000 to 3000 in-lbs: ISO 5211 F07 and F10 bolt circles, 1" female square; see "Dimensions" section and "How to Order " table for additional output options.
<b>Duty Cycle</b>	The actuator may run continuously at temperatures at/below 104° F for up to 15 minutes. After that 15 minutes, the actuators may run up to 75% duty cycle (between each full cycle), the actuator must rest for 1/3 of the 90 degree cycle time. <b>NOTE:</b> At 50 Hz, the duty cycle is ~60% at 104° F (40°C).
<b>Voltage</b>	115 VAC: 103.5 to 126.5 VAC, 50/60 Hz 230 VAC: 207 to 253 VAC, 50/60 Hz
<b>Limit Switches</b>	<b>(2) Single pole, double throw switches rated for 11A 1/2HP 250 VAC, CSA certified, fuse protected.</b> Two standard switches are used for end of travel control, and for pilot or position indication at terminal 5 and terminal 6. Indication outputs are protected by 0.25 AMP permanent auto reset polyfuses – reset time approximately 3 mins.
<b>Motor</b>	Split phase, capacitor driven motor with Class B or better insulation; sub-fractional horsepower
<b>Lubrication</b>	Permanently lubricated gear train and bearings
<b>Gear Train</b>	Hardened steel spur gears
<b>Approximate Weight</b>	17 lbs (8 kg) for sizes up to 600 lb•in (50 lb•ft; 68 Nm) 31 lbs (14 kg) for sizes 1000 lb•in (83 lb•ft; 113 Nm) and above
<b>Enclosure</b>	Die cast aluminum; with a baked-on, super durable polyester powder coat finish
<b>Cover Screws</b>	Captive cover screws for models starting with V are Class 12.9, M6 x 1.0 x 30 mm socket head cap screw; tighten to between 48 - 72 in•lb (for non-lubricated fasteners). Captive cover screws for models starting with LV are Class 12.9, M8 x 1.25 x 36 mm socket head cap screw; tighten to between 10 - 12 ft•lb (for non-lubricated fasteners).

# 6.1 DIMENSIONS

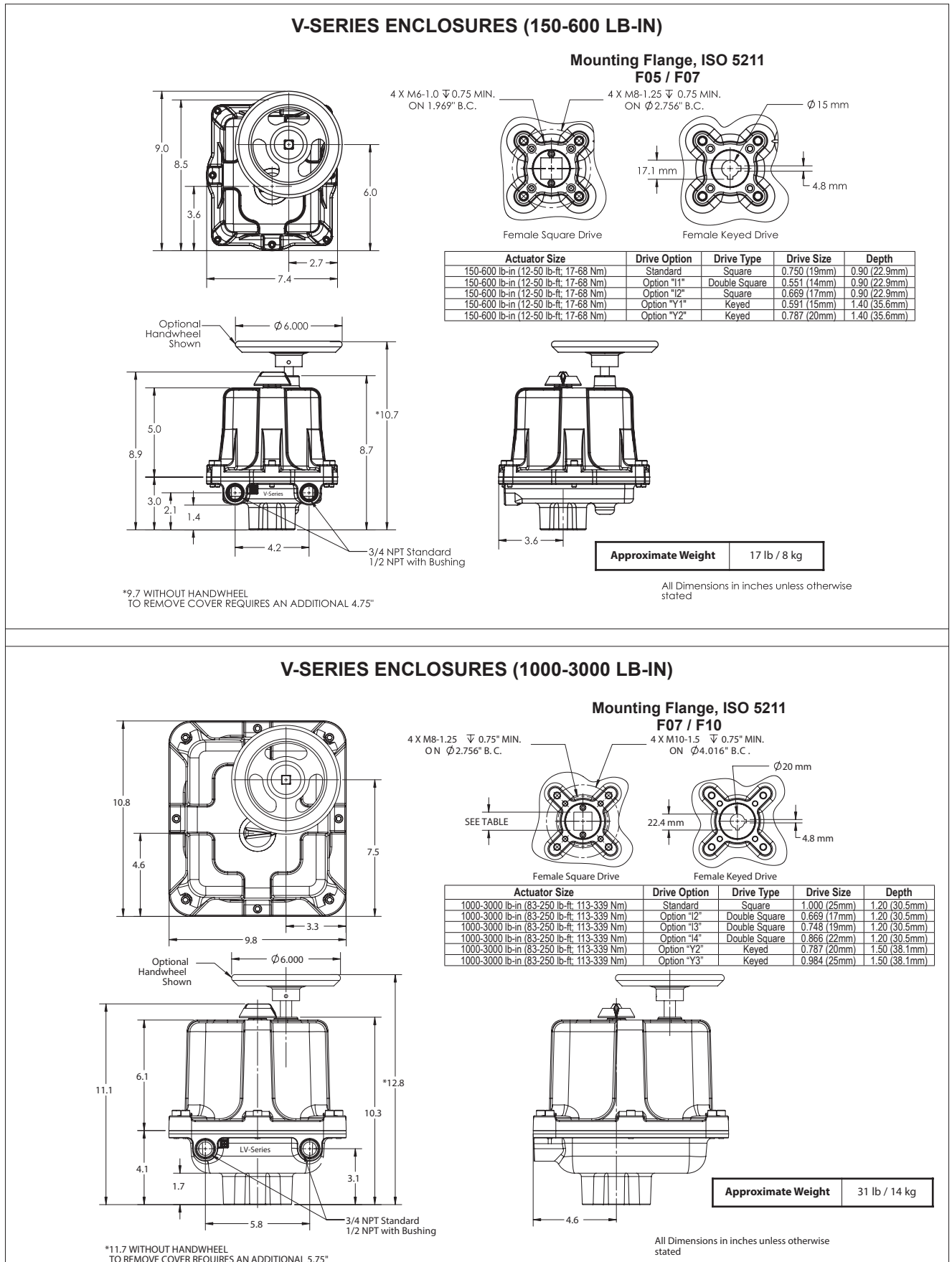
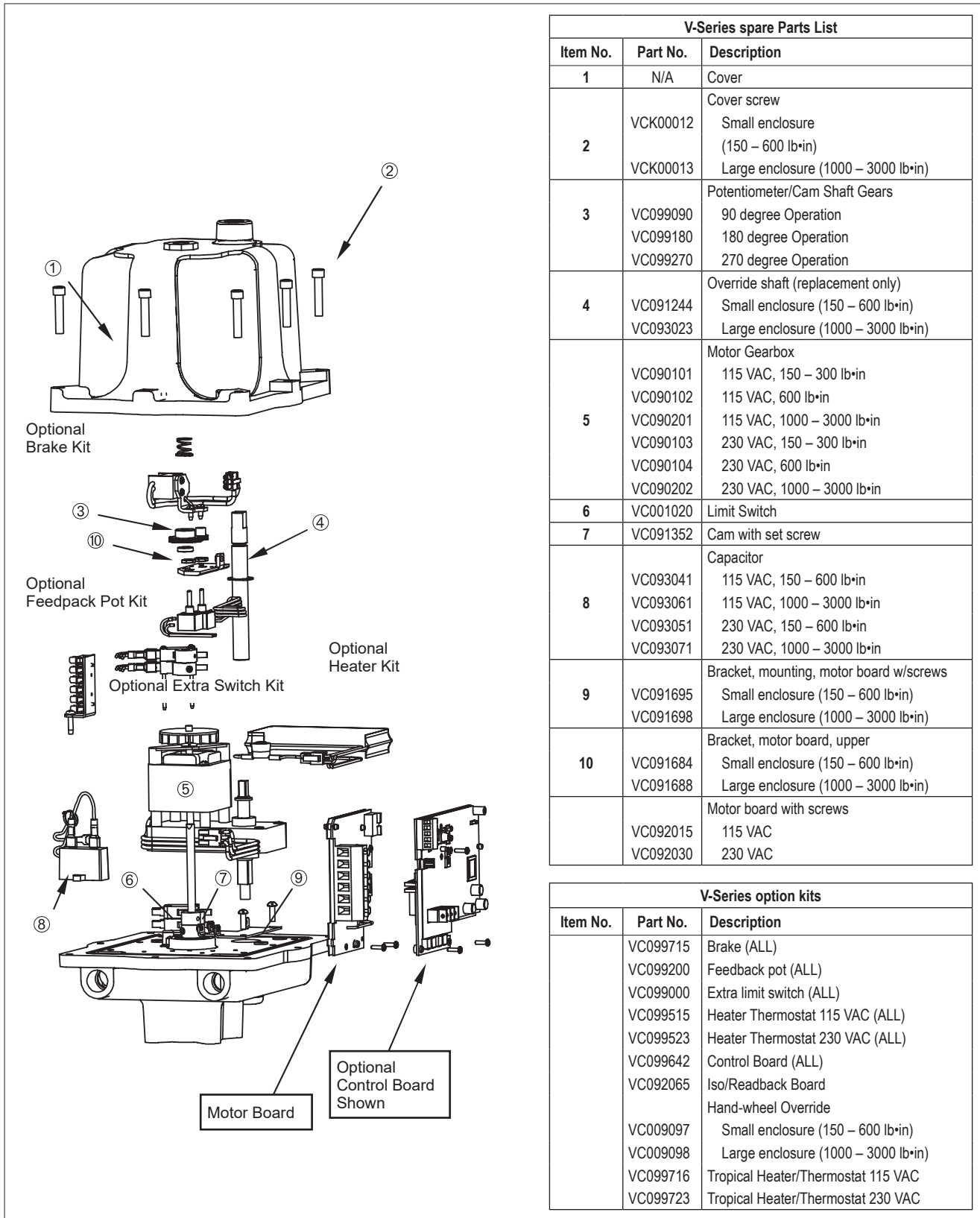

Figure 13.

## 6.2 EXPLODED VIEW



V-Series spare Parts List		
Item No.	Part No.	Description
1	N/A	Cover
2	VCK00012	Cover screw
		Small enclosure (150 – 600 lb•in)
	VCK00013	Large enclosure (1000 – 3000 lb•in)
3	VC099090	Potentiometer/Cam Shaft Gears
	VC099180	90 degree Operation
	VC099270	180 degree Operation
4	VC091244	270 degree Operation
	VC093023	Override shaft (replacement only)
5	VC090101	Small enclosure (150 – 600 lb•in)
	VC090102	Large enclosure (1000 – 3000 lb•in)
	VC090201	Motor Gearbox
	VC090103	115 VAC, 150 – 300 lb•in
	VC090104	115 VAC, 600 lb•in
	VC090202	115 VAC, 1000 – 3000 lb•in
6	VC001020	230 VAC, 150 – 300 lb•in
7	VC091352	230 VAC, 600 lb•in
8	VC093041	230 VAC, 1000 – 3000 lb•in
	VC093061	Capacitor
	VC093051	115 VAC, 150 – 600 lb•in
9	VC091695	115 VAC, 1000 – 3000 lb•in
	VC091698	230 VAC, 150 – 600 lb•in
10	VC091684	230 VAC, 1000 – 3000 lb•in
	VC091688	Bracket, mounting, motor board w/screws
	VC092015	Small enclosure (150 – 600 lb•in)
	VC092030	Large enclosure (1000 – 3000 lb•in)
		Bracket, motor board, upper
		Motor board with screws
		115 VAC
		230 VAC

V-Series option kits		
Item No.	Part No.	Description
	VC099715	Brake (ALL)
	VC099200	Feedback pot (ALL)
	VC099000	Extra limit switch (ALL)
	VC099515	Heater Thermostat 115 VAC (ALL)
	VC099523	Heater Thermostat 230 VAC (ALL)
	VC099642	Control Board (ALL)
	VC092065	Iso/Readback Board
		Hand-wheel Override
	VC009097	Small enclosure (150 – 600 lb•in)
	VC009098	Large enclosure (1000 – 3000 lb•in)
	VC099716	Tropical Heater/Thermostat 115 VAC
	VC099723	Tropical Heater/Thermostat 230 VAC

Figure 14.

## 7. V-SERIES ACTUATORS BY MODEL NUMBER

How To Order - V-Series Electric Actuators										
Actuator Series	Enclosure Type		Torque		Board Options (see note 1)		Other Options (if desired)		Operating Voltage	
	Order Code		Order Code	Description	Order Code	Description	Order Code	Description	Order Code	Description
V	W	Weathertight	150	150 in lb	C	Control Board	H (see note 2)	Tropical Heater/Thermostat	N115AC	115VAC
		NEMA 4/4X	300	300 in lb	J	Speed Control/Timer Board	I1 (see note 3)	14mm Female Square Output	N230AC	230VAC
	WX	Weathertight & Explosionproof	600	600 in lb	U	Iso/Readback Board	I2 (see note 3)	17mm Female Square Output		
NEMA 4/4X/7&9w						K	Brake			
						P	Feedback Potentiometer			
						S2	Two Auxiliary Limit Switches			
						T (see note 4)	Heater/Thermostat			
						Y1 (see note 3)	15mm Female Keyed Output			
						Y2 (see note 3)	20mm Female Keyed Output			
						Z	Handwheel			
LV	W	Weathertight	1000	1000 in lb	C	Control Board	H (see note 2)	Tropical Heater/Thermostat	N115AC	115VAC
		NEMA 4/4X	1500	1500 in lb	J	Speed Control/Timer Board	I2 (see note 3)	17mm Female Square Output	N230AC	230VAC
			2000	2000 in lb	U	Iso/Readback Board	I3 (see note 3)	19mm Female Square Output		
	WX	Weathertight & Explosionproof	2500	2500 in lb			I4 (see note 3)	22mm Female Square Output		
		NEMA 4/4X/7&9	3000	3000 in lb			K	Brake		
							P	Feedback Potentiometer		
						S2	Two Auxiliary Limit Switches			
						T (see note 4)	Heater/Thermostat			
						Y2 (see note 3)	20mm Female Keyed Output			
						Y3 (see note 3)	25mm Female Keyed Output			
						Z	Handwheel			

### NOTES:

- Select only one board option, as needed.
- This heater option activates at or below 90°F and deactivates at 110°F; it is recommended in high-humidity applications.
- The standard drive output for 150 - 600 lb-in actuators is a 3/4" female square; the standard drive output for 1000 - 3000 lb-in actuators is a 1" female square.
- This heater option activates at or below 40°F and deactivates at 60°F; it is recommended in applications where the temperature may drop below 32°F.

For enclosure specifications and dimensions see (Tables 1-2 and Figure 13).

- Enclosure "W"** (weathertight) is certified by CSA to meet specifications for NEMA 4/4X; IP 66 for weathertight and dust-tight, environments and is CE compliant. It is intended for non-hazardous locations; indoor or outdoor use.
- Enclosure "WX"** (weathertight & explosionproof) is certified by CSA to meet specifications for NEMA 7&9, hazardous locations, (Class I, Division 1, Groups C, and D; Class II, Division 1, Groups E, F, and G; Class III) as well as to meet NEMA 4/4X and IP 66 specifications. The enclosure is CE compliant, certified to ATEX directive 2014/34/EU: Ex db IIB T6 Gb, and IECEx CSA 14.0057X.

**Sample Model Code: LVW1500CHI3KS2N230AC**

Actuator Series	LV
Enclosure Type	W
Torque	1500
Board Option	C
Other Options (if applicable)	H I3 K S2
Operating Voltage	N230AC

- Torque = Breakaway Torque** Valvcon™ electric actuators are rated at breakaway torque. This is the torque required to move a full load immediately upon power-up.

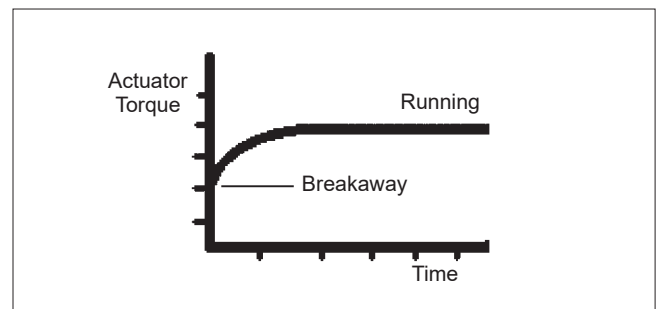

Figure 15.

# 8. DECLARATION OF CONFORMITY



**Manufacturer:**

Neles USA Inc.  
 44 Bowditch Drive  
 Shrewsbury, MA 01545 USA

This declaration of conformity is issued under the sole responsibility of the manufacturer.

**Products:**

VALVCON™ Electric Actuators – Series V, and LV

Model – Type	Certificates / Directives / Standards	Marking
Models beginning with VWX150, VWX300, VWX600, or LVWX1000, LVWX1500, LVWX2000, LVWX2500, and LVWX3000	EU Type-Examination Certificate # Sira 13ATEX1166X ATEX 2014/34/EU MD 2006/42/EC EMC 2004/108/EC EN IEC 60079-0:2018 EN 60079-1:2014  IECEx Certificate of Conformity IECEx CSA 14.0057X IEC 60079-0:2017 IEC 60079-1:2014-06	  Ex db IIB T6 Gb Sira 13ATEX1166X IECEx CSA 14.0057X
Models beginning with VW150, VW300, VW600, or LVW1000, LVW1500, LVW2000, LVW2500, and LVW3000	MD 2006/42/EC EMC 2004/108/EC	

**Specific Conditions of Use:**

- i. The maximum constructional gap (ic) is 0.038 mm which is less than that specified in Table 2 of EN 60079-1:2014.
- ii. Flameproof joints are not intended to be repaired.
- iii. Cover captive screws Class 12.9, M8 x 1.25 x 36 mm socket head shall be used on LVWX Series and Class 12.9, M6 x 1.0 x 30 mm socket head shall be used on VWX Series.

**ATEX Notified Bodies for the EU-Type Examination Certificates:**

Sira Hawarden, UK (Notified Body Number 0518)

**Quality Assurance Certificates:**

ISO 9001:2015 73538-2010-AQ-FIN-FINAS  
 ATEX 2014/34/EU Annex IV Presafe 18 ATEX 91983Q (Notified Body Number 2460)

We declare that the products, as described, are in conformity with the listed standards and directives.

Place of Issue: Shrewsbury, MA USA

Date of Issue: June 1, 2020



Matti Rousku, Quality Manager  
 Neles USA Inc.



## 9. ADDITIONAL ACTUATOR PRODUCTS AND ACCESSORIES FROM NELES

### ADC-Series

- Universal Control Board for On/Off and Modulating applications
- Up to 3000 inch pounds (250 lb•ft; 339 Nm)
- Optional Internal Battery Back-Up
- Continuous Duty Cycle
- Universal Input Power: 115VAC, 230VAC, 24VAC, 12VDC or 24VDC
- NEMA 4/4X and NEMA 4/4X/7&9 enclosures
- CSA (C US) Certified
- CE Compliant
- Certified to ATEX Directive 2014/34/EU: Ex db IIB T6 Gb, and IECEx CSA 14.0057X (“WX” models only)
- IP 66
- Standard Features: auxiliary limit switches, heater/thermostat, manual override and visual position indicator
- Available Options: metric and “keyed” female outputs, MODBUS® and handwheel override

### ESR-Series

- Up to 600 inch pounds (50 lb•ft; 68 Nm) for true “Two-Wire” On/Off applications
- 80% Duty Cycle
- 115VAC and 230VAC voltages
- NEMA 4/4X and NEMA 4/4X/7&9 enclosures
- Available Options: dynamic brake, extra limit switches, heater/thermostats and metric and “keyed” female outputs

### I-Series Network Capable

- AS-Interface
- DeviceNet™
- Foundation Fieldbus
- Other fieldbus protocols (consult factory)
- CSA Certified to Canadian and U.S. standards

### QX-Series

- Up to 3000 inch pounds (250 lb•ft; 339 Nm) for On/Off applications
- Economical NEMA 4/4X/7&9 solution
- 12VDC & 24VDC voltages
- 80% Duty Cycle
- CSA (C US) Certified
- Standard Features: auxiliary limit switches, dynamic brake, manual override and visual position indicator
- Available Options: metric and “keyed” female outputs, heater/thermostats and handwheel override

### LCR Series

- Up to 600 inch pounds (50 lb•ft; 68 Nm)
- Economical actuators for Reversing applications
- 25% duty cycle (80% on 12VDC or 24VDC models)
- NEMA 4/4X enclosure
- 115VAC, 230VAC, 24VAC, 12 VDC and 24VDC voltages
- Options include extra limit switches and heater/thermostats
- Male output (standard) or female output (optional)

### LCU Series

- Up to 600 inch pounds (50 lb•ft; 68 Nm)
- Economical actuators for Unidirectional applications
- 25% duty cycle (80% on 12VDC or 24VDC models)
- NEMA 4/4X enclosure
- 115VAC, 230VAC, 24VAC, 12 VDC and 24VDC voltages
- Options include extra limit switches and heater/thermostats
- Male output (standard) or female output (optional)

### Q6-Series for Remote Solar Applications

- 600 inch pounds (50 lb•ft; 68 Nm)
- 12VDC
- Low current draw
- 80% Duty Cycle
- NEMA 4/4X/7&9
- CSA (C US) Certified





**Valmet Flow Control Oy**

Vanha Porvoontie 229, 01380 Vantaa, Finland.

[flowcontrol@valmet.com](mailto:flowcontrol@valmet.com)

Tel. +358 10 417 5000.

[www.valmet.com/flowcontrol](http://www.valmet.com/flowcontrol)

Subject to change without prior notice.

Neles, Neles Easyflow, Jamesbury, Stonel, Valvcon and Flowrox, and certain other trademarks, are either registered trademarks or trademarks of Valmet Oyj or its subsidiaries in the United States and/or in other countries.

For more information [www.neles.com/trademarks](http://www.neles.com/trademarks)

