

INSTALLATION, USE AND MAINTENANCE MANUAL

PNEUMATIC ACTUATOR

“DA15 - DAN1920” “SR15 - SRN960”

“DD” “DAV” “SRV”







“DA” DOUBLE ACTING VERSION



“SR” SPRING RETURN VERSION

INDEX:

1) GENERAL FEATURES	pag. 3
2) WORKING CONDITIONS	pag. 3
3) OPERATION AND ROTATION DIRECTION	pag. 9
4) SAFETY INFORMATION	pag. 10
5) INSTALLATION INSTRUCTION	pag. 10
6) MATERIALS AND THEIR DURABILITY 	pag. 17
7) MAINTENANCE 	pag. 23
8) SPECIAL VERSIONS	pag. 26
9) STORAGE 	pag. 27
10) TROUBLESHOOTING	pag. 28
11) DISPOSAL OF PRODUCTS AT THE END OF THEIR LIFE CYCLE 	pag. 28
12) DECLARATION OF CONFORMITY	pag. 28
 = Environmental friendly: under the green leaf icon you can find the instructions for a correct and environmentally friendly handling of the product.	

FOREWORD

The present User's Installation and Maintenance Manual has been edited in conformity with:

2006/42/EC Directive "Machinery";

2014/34/UE Directive "Equipment and protection systems designated to be used in potentially explosive atmospheres" (ATEX).

The following standards/technical specifications also apply:

EN 15714-3:2009 Industrial valves: Actuators – Pneumatic part-turn actuators for industrial valves.

IEC 61508:2010-1/7 Functional safety of electrical/electronic/programmable electronic safety-related systems . Part 1 :7

UNI CEN/TS 764-6:2005 Pressure equipment Part 6: Operating instructions structure and contents.

Below you will find the safety instructions, the minimum information for storage / warehousing, the installation, the commissioning, the maintenance and the instructions for disposal of products at the end of their life cycle for the following pneumatic actuators:

A) DOUBLE ACTING PNEUMATIC ACUATOR: Series DA015-DA030-DA045-DA060-DA090-DA120-DA180-DA240-DA360-DA480-DA720 -DA920-DAN1440- DAN1920

B) SPRING RETURN PNEUMATIC ACTUATOR: Series SR015-SR030-SR045-SR060-SR090-SR120-SR180-SR240-SR360-SR480-SRN720-SRN960

C) TWO STAGE PNEUMATIC ACTUATOR: Series DD030-DD060-DD120-DD240-DD480

Where provided, the actuators are CE marked in accordance with the applicable European Directives

(ex. 2014/34/UE - ATEX).

OMAL S.p.A. disclaims any liability for damage caused by improper use, even if partial, respect to the information contained in this manual.

OMAL S.p.A. reserves the right to change, at any time, the features and data of its own products, to better improve the quality and the duration of said products.

OMAL S.p.A.

Headquarters: Via Ponte Nuovo, 11 - 25050 Rodengo Saiano (BS) Italy · Production Site: Via Brognolo, 12 - 25050 Passirano (BS) Italy

Ph. +39 030 8900145 · Fax +39 030 8900423 · info@omal.it · www.omal.com

1) GENERAL FEATURES

OMAL S.p.A. produces a wide range of pneumatic actuators, with "Scotch yoke" mechanism, for valve drive and remote control. Such actuators are available both in the double acting "DA" version and in the spring return "SR" version.

The use of an actuator is based on the principle of opening and closing the valve connected to it, without manual operations by means of levers or hand-wheels, but through an electro-pneumatic remote control.

The "Scotch yoke" mechanism is a mechanical system designed to transform the linear force into a torsion-type force.

OMAL S.p.A. uses this system, when producing its actuators, to transfer the linear force of the pistons to the movement of the valve shaft.

This system provides a long life for the actuator and the best performance, with the least energy consumption.

The OMAL S.p.A. Scotch yoke system has a torque curve that makes the maximum torque available right at the breakaway of the valve, the initial opening moment.

2) WORKING CONDITIONS

a. Structure

The OMAL S.p.A. actuators can be used both for indoor and outdoor installations. The technical characteristics such as: the type, the size, the maximum operating pressure, the torque supplied, the maximum operating temperature, the flange type, the serial and production number, are laser engraved on the actuator body (see drawing on page 8).

b. Supply fluid

The supply fluid must be compressed, filtered and dry air, not necessarily lubricated, or other inert gases compatible with the internal parts and lubricants used in the actuator. The supply fluid must have a dew point of at least 10°C below the minimum temperature indicated on the actuator. The dimensions of the particles, possibly contained, must not exceed 40 µm (ISO 8573-1, class 5) - EN 15174-3 points 3.4.5.2

c. Operating pressure

The maximum operating pressure is 8,4 bar (120 psi). The nominal operating pressure is that which can be found on the plate or on the actuator directly.

d. Operating temperature

The operating temperature can be found on the plate and can vary according to the types of seals that are being used.

The OMAL S.p.A. actuators work within a temperature range that goes from -20°C (-4°F) to 80°C (176°F); there are also available versions that can be used with low or high temperature (paragraph 8).

e. Stroke of the actuators

The OMAL S.p.A. actuators are produced for a standard stroke of a 91° rotation, an adjustment that reduces the stroke by 10° (in the closed valve position) is available upon request.

f. Opening and closing rates

The cycle rate depends on different factors such as the supply pressure, the capacity, the connection sizes, the characteristics of the solenoid valves, the valve torque and its characteristics and the room temperature.

The rates in the following charts relate to the actuator only and have been recorded with the help of the limit switches located on the actuator shaft. The rates are therefore exactly what is required by the actuator for a 90° rotation, counting from the instant that the movement begins until the end of the stroke.

TECHNICAL DEPARTMENT

DOUBLE ACTING ACTUATOR -OPEN CLOSED TIMING - with **SOLENOID VALVE NAMUR 5/2 1/4"**
 TEMPI DI APERT. CHIUS. - ATTUATORI DOPPIO EFFETTO - con **ELETTROVALVOLA NAMUR 5/2 1/4"**

Test conditions	Condizioni di prova
Actuators tested are representative of production	Attuatori rappresentativi della produzione
Test temperature: +18 ° C +25 ° C	Temperatura ambiente di prova: +18°C +25°C
Load: no load	Carico: nessun carico
Control fluid: compressed air at 0.56MPa / 5.6bar	Fluido di comando: aria compressa a 5.6bar
Nominal cycle: 90 ° in both directions	Ciclo nominale: 90° in entrambe le direzioni
Control	Controllo
3/2 - 5/2 solenoid valve monostable Namur	Elettrovalvola 3/2 - 5/2 monostabile NAMUR
Pneumatic connections: 1/4" gas	Conessioni pneumatiche: 1/4"gas.
Bore diameter: 1/4" - exhaust 1/4"	Diametro passaggio: 1/4" - scarico 1/4"
Flow capacity: 675 Nl/min (at Δp.1 bar)	Portata: 675 Nl/min (con Δp.1 bar)
Instruments for testing	Strumenti di misura
Digital chronometer controlled by proximity switches	Cronometro digitale e finecorsa di prossimità

A SOLENOID VALVE NAMUR 5/2 1/4" - Elettrovalvola Namur 5/2 1/4"

A+B 5/2 1/4" SOLENOID V. NAMUR+1/4" QUICK EXHAUST - Elettrov. Namur 5/2 1/4"+scar. Rapido 1/4"

time in seconds	A		A+B	
	OPEN	CLOSED	OPEN	CLOSED
	5.6 bar	5.6 bar	5.6 bar	5.6 bar
(1) DA 8	0.05	0.05	0.05	0.05
(2) DA 15	0.06	0.04	0.06	0.04
(3) DA 30	0.08	0.08	0.08	0.08
(3) DA 45	0.15	0.10	0.15	0.10
(3) DA 60	0.10	0.09	0.11	0.09
(3) DA 90	0.11	0.13	0.11	0.13
(3) DA 120	0.15	0.15	0.14	0.14
(3) DA 180	0.20	0.21	0.20	0.21
(3) DA 240	0.28	0.25	0.28	0.24
(3) DA 360	0.38	0.36	0.35	0.35
(3) DA 480	0.46	0.40	0.44	0.37
(3) DA 720	0.64	0.59	0.59	0.55
(3) DA 960	0.81	0.73	0.75	0.68
(3) DAN 1440	1.42	1.38	1.32	1.27
(3) DAN 1920	1.64	1.54	1.59	1.40

A ER8188C2 (24 DC)

B 1/4"Quick Exhaust



(1) KBN10008

(2) KBN10015

(3) KBN17030

Note: different working conditions as: air pressure, pipe connections, filters, solenoid valves could change the operating times

Nota: differenti condizioni di lavoro quali: pressione dell'aria, connessioni di raccordo, filtri, elettrovalvole possono cambiare i tempi di manovra

(1)(2)(3) Mounting with the correct plate as per NAMUR specifications

(1)(2)(3) Montaggio con basetta corretta con piano di posa conforme Namur

TECHNICAL DEPARTMENT

SPRING RETURN ACTUATOR - OPEN CLOSED TIMING - with **SOLENOID VALVE NAMUR 3/2 1/4"**
 TEMPI DI APERT. CHIUS. - ATTUATORI SEMPLICE EFFETTO - con **ELETTROVALVOLA NAMUR 3/2 1/4"**

Test conditions	Condizioni di prova
Actuators tested are representative of production	Attuatori rappresentativi della produzione
Test temperature: +18 ° C +25 ° C	Temperatura ambiente di prova: +18°C +25°C
Load: no load	Carico: nessun carico
Control fluid: compressed air at 0.56MPa / 5.6bar	Fluido di comando: aria compressa a 5.6bar
Nominal cycle: 90 ° in both directions	Ciclo nominale: 90° in entrambe le direzioni
Control	Controllo
3/2 - 5/2 solenoid valve monostable Namur	Elettrovalvola 3/2 - 5/2 monostabile NAMUR
Pneumatic connections: 1/4" gas	Connessioni pneumatiche: 1/4"gas.
Bore diameter: 1/4" - exhaust 1/4"	Diametro passaggio: 1/4" - scarico 1/4"
Flow capacity: 675 NI/min (at Δp.1 bar)	Portata: 675 NI/min (con Δp.1 bar)
Instruments for testing	Strumenti di misura
Digital chronometer controlled by proximity switches	Cronometro digitale e fincorsa di prossimità

A SOLENOID VALVE NAMUR 3/2 1/4" - Elettrovalvola Namur 3/2 1/4"

A+B 3/2 1/4" SOLENOID V. NAMUR+1/4" QUICK EXHAUST - Elettrov. Namur 3/2 1/4"+scar. Rapido 1/4"

time in seconds	A		A+B	
	OPEN	CLOSED	OPEN	CLOSED
	5.6 bar	spring	5.6 bar	spring
(1) SR 15	0.13	0.09	0.13	0.09
(1) SR 30	0.13	0.10	0.12	0.09
(1) SR 45	0.14	0.16	0.15	0.15
(1) SR 60	0.21	0.17	0.20	0.16
(1) SR 90	0.31	0.26	0.28	0.24
(1) SR 120	0.40	0.33	0.37	0.30
(1) SR 180	0.58	0.44	0.53	0.42
SR 240	0.65	0.53	0.57	0.45
SR 360	0.96	0.72	0.89	0.59
SR 480	1.16	0.90	1.03	0.83
SRN 720	2.72	1.62	2.43	1.44
SRN 960	2.74	2.15	2.55	2.00



A ER8188C2 (24 DC)



B 1/4"Quick Exhaust



(1) KBN17030



(1) Mounting with plate KBN17030 as per NAMUR specifications

(1) Montaggio con basetta KBN17030 con piano di posa conforme Namur

Note: different working conditions as: air pressure, pipe connections, filters, solenoid valves could change the operating times

Nota: differenti condizioni di lavoro quali: pressione dell'aria, connessioni di raccordo, filtri, elettrovalvole possono cambiare i tempi di manovra

TECHNICAL DEPARTMENT

SPRING RETURN ACTUATOR - OPEN CLOSED TIMING - with **SOLENOID VALVE 3/2 1/8"**
 TEMPI DI APERT. CHIUS. - ATTUATORI SEMPLICE EFFETTO - con **ELETTROVALVOLA 3/2 1/8"**

Test conditions	Condizioni di prova
Actuators tested are representative of production	Attuatori rappresentativi della produzione
Test temperature: +18 ° C +25 ° C	Temperatura ambiente di prova: +18°C +25°C
Load: no load	Carico: nessun carico
Control fluid: compressed air at 0.56MPa / 5.6bar	Fluido di comando: aria compressa a 5.6bar
Nominal cycle: 90 ° in both directions	Ciclo nominale: 90° in entrambe le direzioni
Control	Controllo
3/2 solenoid valve direct mounting coil included	Elettrovalvola 3/2 montaggio diretto con bobina
Pneumatic connections: 1/8" gas	Conessioni pneumatiche: 1/8" gas.
Bore diameter: 1,8mm - exhaust 1,8mm	Diametro passaggio: 1,8mm - scarico 1,8mm
Flow capacity: 80 NI/min	Portata: 80 NI/min
Instruments for testing	Strumenti di misura
Digital chronometer controlled by proximity switches	Cronometro digitale e finecorsa di prossimità

- A** SOLENOID VALVE 3/2 1/8"- Elettrovalvola 3/2 1/8"
- A+B** 3/2 1/8" SOLENOID VALVE+1/8" QUICK EXHAUST - Elettrovalvola 3/2 1/8"+scarico rapido1/8"
- A+C** 3/2 1/8" SOLENOID VALVE+1/4" QUICK EXHAUST - Elettrovalvola 3/2 1/8"+scarico rapido1/4"

time in seconds	A		A+B		A+C	
	OPEN	CLOSED	OPEN	CLOSED	OPEN	CLOSED
	5.6 bar	spring	5.6 bar	spring	5.6 bar	spring
SR 15	0.21	0.34	0.23	0.12		
SR 30	0.39	0.59	0.42	0.08		
SR 45	0.54	0.85	0.58	0.13		
SR 60	0.78	1.08	0.85	0.13		
SR 90	1.17	1.62	1.29	0.20		
SR 120	1.54	2.32	1.69	0.25		
SR 180	2.20	3.24	2.42	0.33		
SR 240	2.75	4.30			2.94	0.44
SR 360	4.35	6.35			4.64	0.57
SR 480	5.00	7.75			5.35	0.71
SRN 720	10.86	19.50			11.23	2.60
SR 960	15.44	23.55			16.60	2.83



A EP612024 (24 DC)



B 1/8" Quick Exhaust

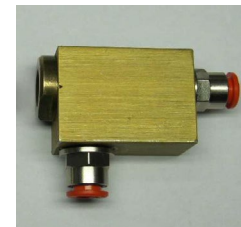

C 1/4" Quick Exhaust

Note: different working conditions as: air pressure, pipe connections, filters, solenoid valves could change the operating times
Nota: differenti condizioni di lavoro quali: pressione dell'aria, connessioni di raccordo, filtri, elettrovalvole possono cambiare i tempi di manovra

SPRING RETURN ACTUATOR - OPEN CLOSED TIMING - with MICRO SOLENOID VALVE 24Vdc
TEMPI DI APERT. CHIUS. - ATTUATORI SEMPLICE EFFETTO - con MICRO ELETTROVALVOLA 24Vdc

Test conditions	Condizioni di prova
Actuators tested are representative of production	Attuatori rappresentativi della produzione
Test temperature: +18 °C +25 °C	Temperatura ambiente di prova: +18 °C +25 °C
Load: no load	Carico: nessun carico
Control fluid: compressed air at 0.56MPa / 5.6bar	Fluido di comando: aria compressa a 5.6bar
Nominal cycle: 90 ° in both directions	Ciclo nominale: 90 ° in entrambe le direzioni
Control	Controllo
3/2 micro solenoid valve direct mounting coil included	Microelettrovalvola 3/2 montaggio diretto con bobina
Pneumatic connections: 1/8" gas	Connessioni pneumatiche: 1/8" gas.
Bore diameter: 1,3mm - exhaust 0,8mm	Diametro passaggio: 1,3mm - scarico 0,9mm
Flow capacity: 53 NI/min	Portata: 53 NI/min
Instruments for testing	Strumenti di misura
Digital chronometer controlled by proximity switches	Cronometro digitale e finecorsa di prossimità

A MICRO SOLENOID - Micro Elettrovalvola

A+B MICRO SOLENOID+1/8" QUICK EXHAUST - Micro Elettrovalvola+scarico rapido1/8"

time in seconds	A		A+B	
	OPEN	CLOSED	OPEN	CLOSED
	5.6 bar	spring	5.6 bar	spring
SR 15	0.28	0.48	0.30	0.13
SR 30	0.53	0.89	0.56	0.08
SR 45	0.78	1.29	0.82	0.13
SR 60	1.09	1.68	1.16	0.14
SR 90	1.68	2.58	1.80	0.20
SR 120	2.21	3.56	2.35	0.24

A EP412024 (24 DC)



B 1/8" quick exhaust



Note: different working conditions as: air pressure, pipe connections, filters, solenoid valves could change the operating times

Nota: differenti condizioni di lavoro quali: pressione dell'aria, connessioni di raccordo, filtri, elettrovalvole possono cambiare i tempi di manovra

g. Lubrication

The actuators are lubricated, for normal working conditions, in the company. For maintenance or reassembly operations, OMAL S.p.A. recommends the use of a lubricant such as TECNOLUBE SYNTHY POLYMER 402 or equivalent.

h. Functional Safety

The OMAL S.p.A. pneumatic actuators are also suitable for installations which require high level of functional reliability, up to SIL3, in compliance with the IEC 61508 standard.

i. Wear protection of internal components

The cylinder is electrolysis nickel plated internally, in order to reduce roughness of the surface to a minimum value and is protected with an oxidation treatment which is 20µm thick. The guides of the pistons are made of P.T.F.E.. The use of steel bushes on the Scotch yoke system reduce backlash and confer very low friction sliding during operation.

j. External protection

The actuators are suitable both for indoors and outdoors. The aluminum body is protected against corrosion by an oxidation treatment which is 20 µm thick; the caps are varnished with polyester based powder varnish; the shaft and cap screws are made of stainless steel. This generally allows to meet the C4 safety class, for applications that require it, according to the standard EN 15714-3 section 4.4.3. For applications in environments with aggressive type atmospheres that require a higher protection level than C4, the actuator must be protected with a suitable varnishing treatment.

k. Marking and classification

The bodies of the OMAL S.p.A. actuators are marked, by means of laser engraving or a label, with the manufacturer's logo and address, the code or the serial number, the size, the output torque, the working pressure and the maximum working temperature and the production date.

Marking according to EN15714-3:2009 paragraph 6.1

- a) Logo and address of the manufacturer
- b) Model and nominal torque example as figure (DA90)
- c) Production date imprinting
- d) Working pressures: nominal and maximum
- f) Standard flanging

marking instructions where the temperature is different from the standard one:

low temperature version: T. min.= -50°C T. max=60°C
 high temperature version: T. min.= -20°C T. max=150°C

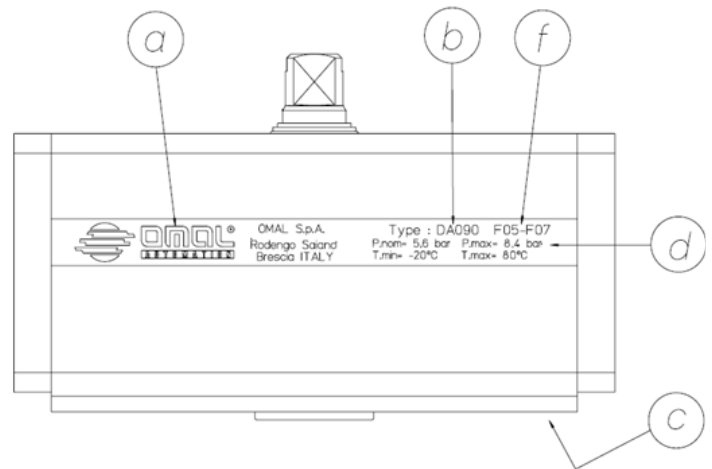

3) OPERATION AND ROTATION DIRECTION

a. Double acting

The actuator pistons are mounted as shown in the figure below. This provides the maximum torque at the beginning of valve opening, for valves that close in a clockwise direction.

Port 2 is in connection with the side chambers of the cylinder, by pressurizing such connection of a standard double-acting actuator DA, the shaft rotates counter-clockwise to open, while port 4 is connected with the intermediate chamber and when pressurized, the drive shaft rotates clockwise to close.

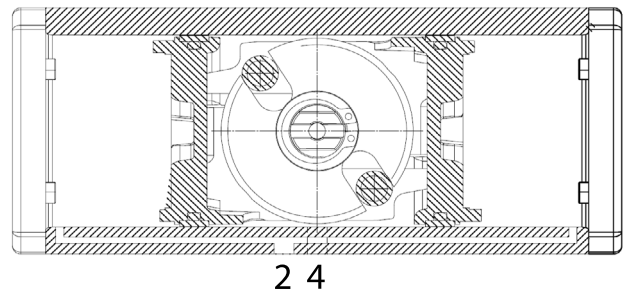

b. Spring return, normally closed

The actuator pistons are mounted as shown in the figure below. Even though the spring force tends to diminish in a linear and constant way, the precise structure of the mechanism supplies a torque increment at the end of the spring stroke. The angular position of the end of the stroke can be adjusted (see pages 14-15).

Caution. Install a filter on connection 2, in order to prevent the access of dust or dirt inside the actuator chambers, during the spring action.

Port 4 is connected to the intermediate chamber and when pressurized, the shaft rotates in a counter-clockwise direction to open, pressing the springs, while cutting the supply off the springs go into action and the drive shaft rotates in a clockwise direction to close.

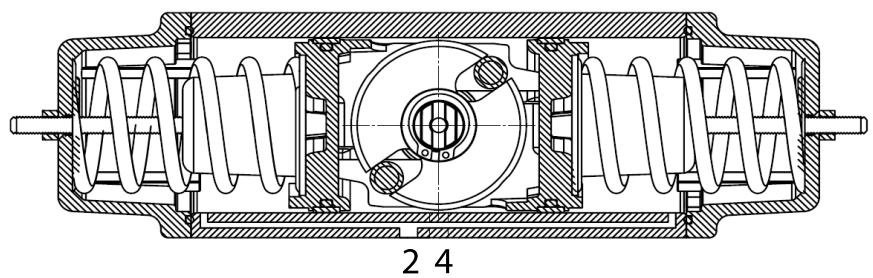

c. Double Acting (DA) actuator working cycle

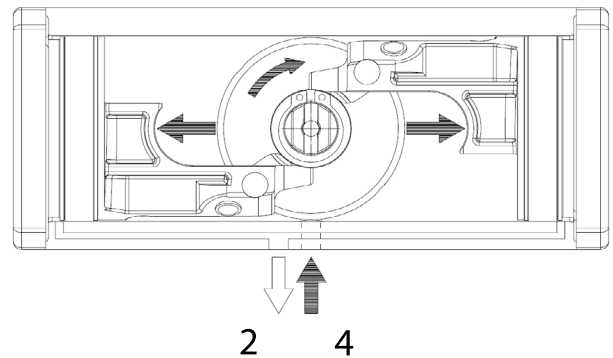
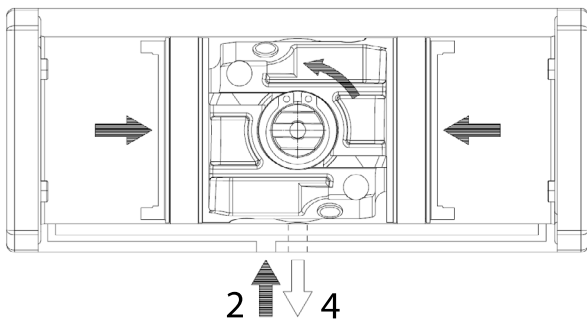

d. Spring Return (SR) actuator working cycle

The remote control functionality of the actuators must be done through a direct connection with solenoid valves and the EN15714-3 - NAMUR (VDI / VDE 3845) standard interface or with pipes screwed on the ports marked with the numbers 2 and 4.

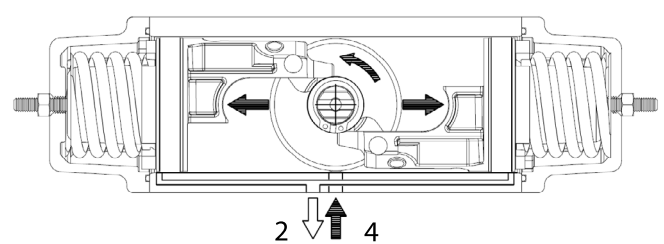
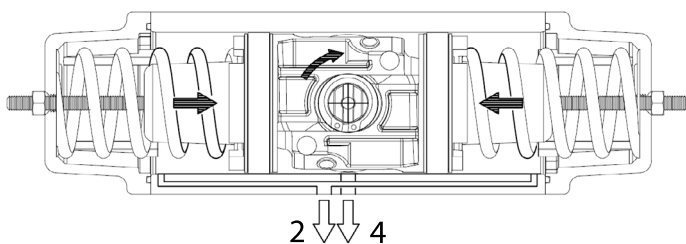

TYPICAL CONNECTION LAYOUT

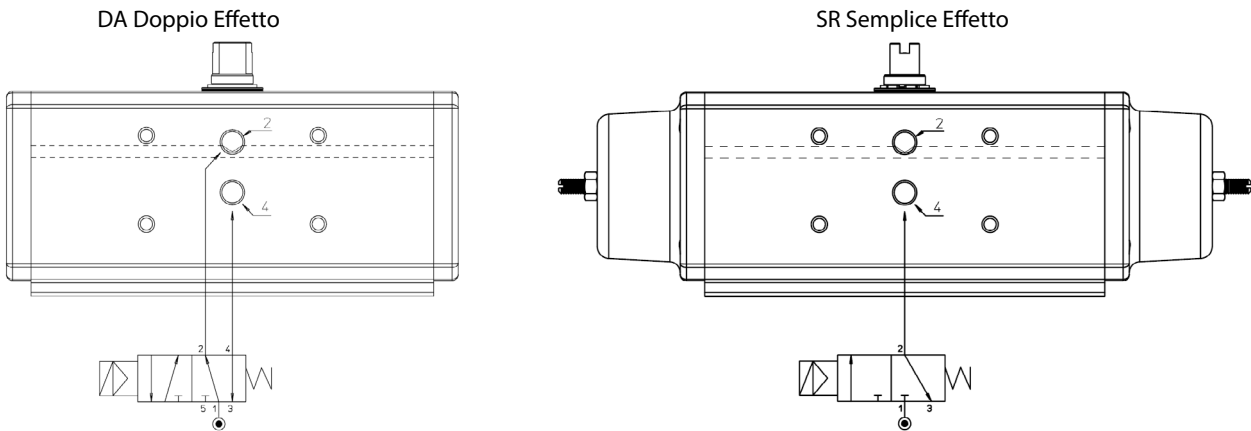

Actuator positioning and rotation direction

The positioning and the rotation direction of the actuator, to ensure a maximum opening torque, must be in conformity with the EN ISO 5211 standard.

4) SAFETY INFORMATION

- The actuator must be used within the specified pressure limits, operation beyond these limits may damage the internal parts of the actuator.
- The actuator operation out of the range of temperatures indicated could damage its internal or external parts.
- Using the actuator, without the due external protection, may damaged it in corrosive environments.
- Before the installation, repair or maintenance be sure that the actuator is not pressurized, disconnect the air lines and verify that they have vented.
- Do not remove the caps when the actuator is installed online or while it's still pressurized.
- Do not remove the spring cap, this operation may be carried out by qualified personnel only; such operation could cause personal injuries.
- Before installing the actuator on the valve be sure that the rotation of one is in phase with the rotation of the other and that the shaft slit position is correct.
- Before installing the actuated valve, carry out a few dry cycles in order to check the proper fitting between valve and actuator.
- Carry out the installation in compliance with the national local regulations and laws.
- Before installing a pneumatic actuator bearing the marking in accordance with Directive 2014/34/EU ATEX, carefully read the additional instructions, supplied together with the product, regarding the use in explosive atmospheres.

OMAL S.p.A. cannot be held responsible for any damage to people, animals or things due to an improper use of the product.

5) INSTALLATION INSTRUCTIONS

The installation of an actuator allows to open and close a valve, which is installed in a system, without manual operation, by means of an electric-pneumatic remote control.

The normal sizing of the actuators requires to consider an appropriate safety margin for the breakaway torque which is necessary for the valve to operate properly. The plant design, physical or chemical characteristics of the fluids, special environmental conditions, may require an increase of the safety factor to be applied to the sizing.

Prior to installation verify that valve and actuator comply with the safety standards described above. Utmost cleanliness is required when connecting the air supply to the actuator. All parts of the plant, reductions, joints, plates, brackets and equipment must be thoroughly cleaned. Before mounting the actuator on the valve be sure that both elements are correctly oriented, depending on the rotation direction needed.

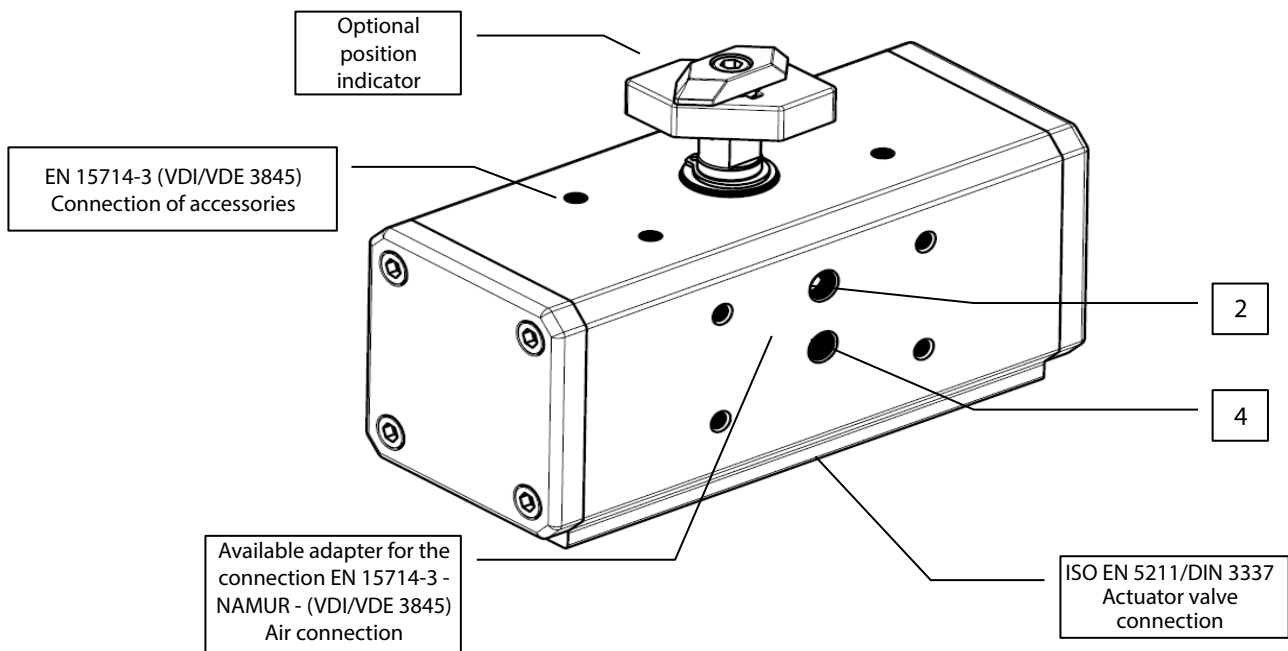

- Before installation, visually check that the conditions of the actuator are good, since it's been transported and stored.
- Verify, through the shaft slot or covers, the position of the actuator.
- Carefully read the OMAL S.p.A. instructions contained in the cardboard box.
- Verify performance and limits found on the actuator body to see whether it's suitable for the application or not.
- Remove the plastic protective covers from the ports and insert whichever filters as pointed out in paragraph 2.
- Prior to mounting the actuator on the valve, clean both from dust and dirt.
- Verify the valve position, closed or open, and the rotation direction.
- Verify the actuator position and the rotation direction based on the valve, especially for the installation of the SR version "normally closed" and "normally open".
- The SR versions "normally closed" are always supplied in the closed position.
- The SR versions "normally open" are always supplied in the open position

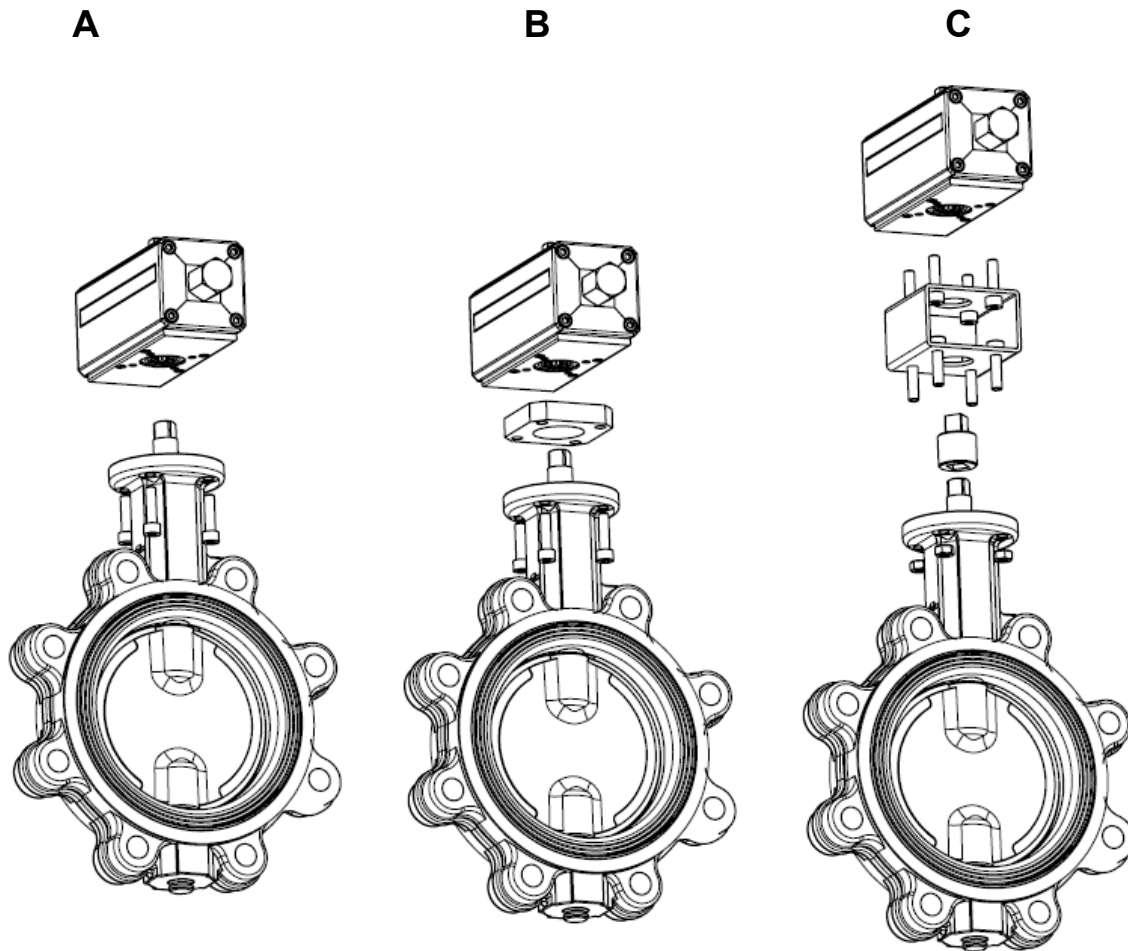

Assembly of Valve/Actuator:

A) DIRECT INSTALLATION

The direct installation of valve and actuator is the best way in order to avoid backlash between the valve stem and the actuator shaft. For direct installation, there should be the same standard flange connection both on the valve and on the actuator, and the dimensions of the valve stem should fit perfectly with those of the actuator shaft. Before installation, please check that the actuator and the valve both have ISO flanges of the same size, also check that the dimensions of the valve stem and its shape are suitable for direct mounting: use a reduction if necessary. Mount the valve stem in the housing on the actuator shaft and bolt the two ISO flanges together.

B) INSTALLATION WITH CONNECTION PLATE

In the cases where a direct installation is not possible, due to small differences between the actuator and valve flanges and/or shafts, it's possible to carry out the installation with a connection plate for easy positioning and of appropriate sizing.

C) ASSEMBLY WITH A BRACKET AND CONNECTION JOINT

Where, for technical installation reasons and due the system, a certain distance is required between the valve and actuator, or the flanges and the valve stem are not standard, or where direct installation is not possible, the right solution is given by a bracket and a connecting joint. The bracket is a steel bridge that allows to connect the valve on one side and the appropriate connection for the actuator on the opposite side, leaving a space for a steel joint. The joint allows the transmission of the torque between the actuator and the valve and is essential in the case of stem drives with keys.

Choose a joint that is appropriate for the flange and the right connections for bolting the actuator on the valve without backlash.

Tightening torque of the screws

Size	Torque Nm
M5	5-6
M6	10-11
M8	20-23
M10	45-50
M12	80-85
M14	125-135
M16	190-200
M20	370-390

Type : DA (Closed Valve)

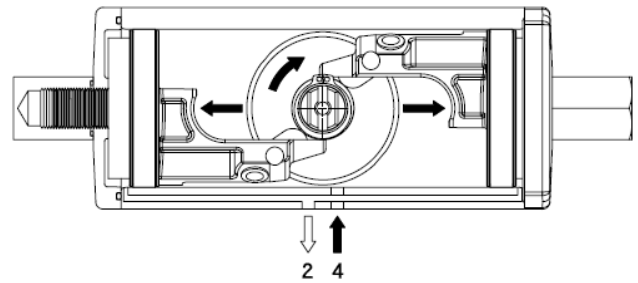
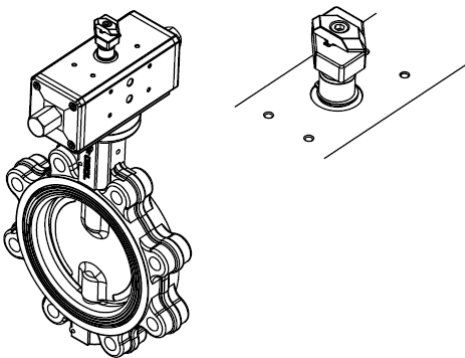

Type : DA (Open Valve)

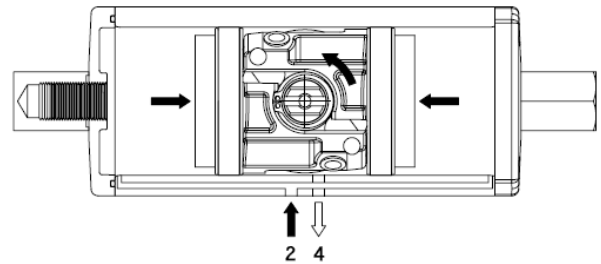
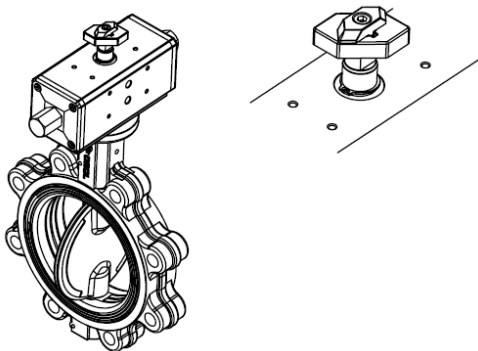

Type : SR (Closed Valve)

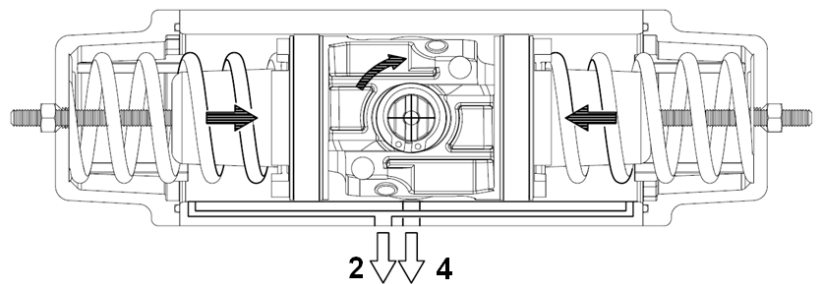
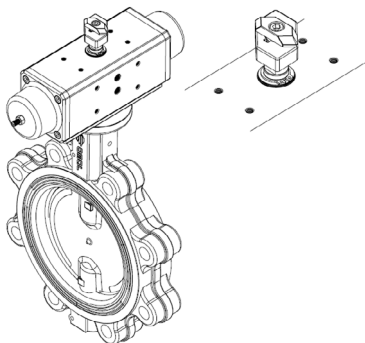

Type : SR (Open Valve)

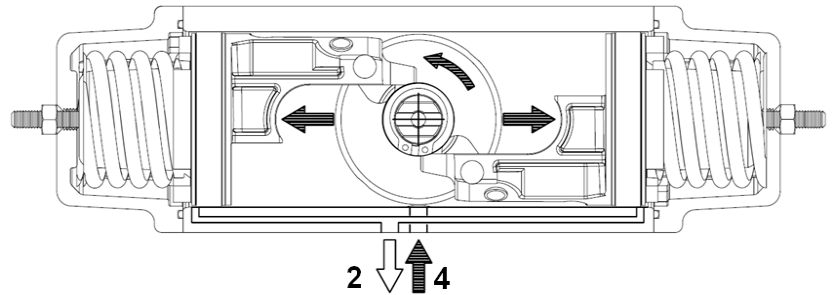
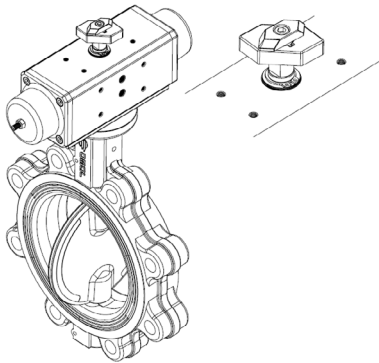

Both versions DA and SR are provided with a standard adjustment of 10°.

Stroke adjustment

a. Instructions for Double Acting DA version. Closing stroke adjustment from 0° to +10°

The stroke adjustment of the actuator, that is mounted on the valve, must be carried out with the valve free from pressure or any other frictions. Furthermore, the actuator must be disconnected from the air supply. This operation must be done when the valve / actuator is secured in the system or in a clamp.

- Apply air pressure to port 2 to open the valve, and to position the actuator pistons inward.
- Remove the cap nuts (ref.18) and the O-rings (ref.24).
- Rotate the adjustment screw in a clockwise direction (ref.28) only on one side of the actuator in order to stop the piston stroke before the 90° available, therefore identifying an early "valve closed" point.
- Apply air pressure to port 4 so to position the pistons outward, therefore resting on the adjustment screw and check the valve closing position.
- If the valve position is not correct repeat the process over again.
- On the contrary, when applying air to port 4, if the valve is not sufficiently closed, unscrew the adjusting screw in the counterclockwise direction (ref.28) until the desired position is found.
- Once the right valve position is obtained, while applying pressure to port 4 screw the adjustment screw located on the other end until it rests against the piston. This way both the adjustment screws will stop the pistons at the same time.
- Tighten the cap nuts (ref.18) with the O-rings (ref.24) in order to fasten the adjustment screws in the desired position.
- The actuator is now ready to function properly.

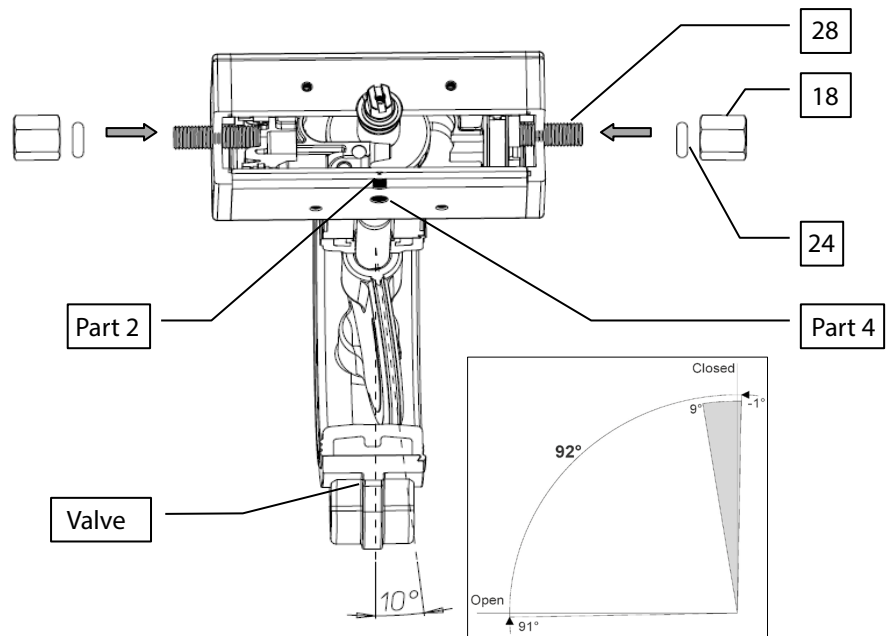

The OMAL S.p.A. standard adjustment is maximum 10°, special length screws are available upon request.

b. Instructions for normally closed Spring Return SR version. Adjustment of the opening stroke from 80° to 90°

The stroke adjustment of the actuator, that is mounted on the valve, must be carried out with the valve free from pressure or any other frictions. Furthermore, the actuator must be disconnected from the air supply. This operation must be done when the valve / actuator is secured in the system or in a clamp.

- Remove the cap nuts (ref.18) and the O-rings (ref.24).

OMAL S.p.A.

Headquarters: Via Ponte Nuovo, 11 - 25050 Rodengo Saiano (BS) Italy · Production Site: Via Brognolo, 12 - 25050 Passirano (BS) Italy
 Ph. +39 030 8900145 · Fax +39 030 8900423 · info@omal.it · www.omal.com

- Rotate the adjustment screw in a clockwise direction (ref.21) only on one side of the actuator.
- Apply air pressure to port 4 so to position the pistons outward, up to the limits determined by the adjustment screw located on the piston head.
- Check the valve open position, if it's too open repeat the process over again.
- On the contrary, when applying air to port 4, if the valve is not sufficiently open, unscrew the adjusting screw in the counterclockwise direction (ref.21) until the desired position is found.
- Once the right valve position is obtained, while applying pressure to port 4 screw the adjustment screw located on the other end until it rests against the piston. This way both the adjustment screws will stop the pistons at the same time.
- Still while air supply under pressure, tighten the cap nuts (ref.18) with the O-rings (ref.24) in order to fasten the adjustment screws in the desired position. The actuator is now ready to function properly.

The OMAL S.p.A. standard adjustment is maximum 10°, special length screws are available upon request.

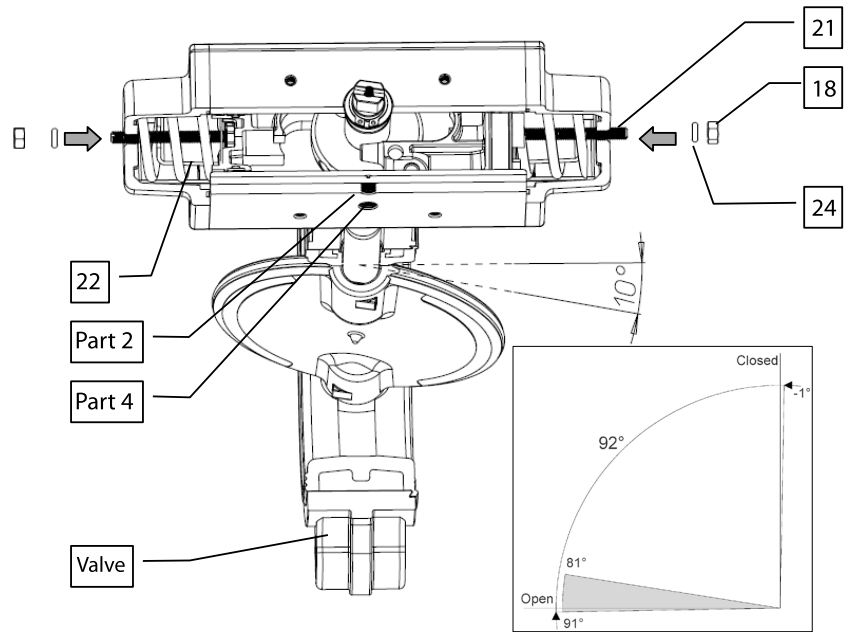

c. Instructions for normally closed Spring Return SR version. Adjustment of the opening stroke from 0° to 10°

The stroke adjustment of the actuator, that is mounted on the valve, must be carried out with the valve free from pressure or any other frictions. Furthermore, the actuator must be disconnected from the air supply. This operation must be done when the valve / actuator is secured in the system or in a clamp.

Remove the cap nuts (ref.18) and the O-rings (ref.24). Apply air pressure to port 4 so to position the pistons outward.

Unscrew, both screws (ref.21), in a counter clockwise direction and by the same amount.

Remove pressure from port 4, thanks to the action of the springs, the pistons will move towards the center up to the limit set by the adjustment screws on the spring caps (ref.22).

***Warning.

Check the valve closing position, if it's not suitable, repeat the operation from the beginning to obtain the desired closed position.

On the contrary, when applying air to port 4, if the valve is too open, unscrew the adjusting screw in the clockwise direction inwards (ref.21) by the same amount.

Without air pressure supply, tighten the cap nuts (ref.18) with the O-rings (ref.24) in order to fasten the adjustment screws in the desired position.

The actuator is now ready to function properly.

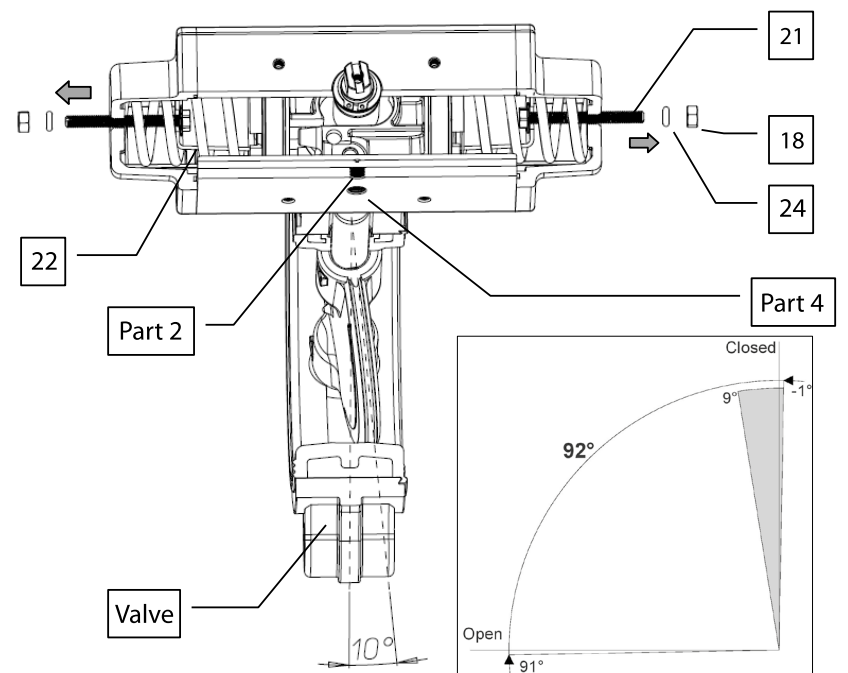

*** Warning: the spring return is not a mechanical phenomenon that acts on the piston stroke or on the stem rotation, the screws limit the strokes of the springs and of the piston. Under these conditions the shaft is not stopped and could theoretically also move up to the fully closed position.

The OMAL S.p.A. standard adjustment is maximum 10°, special length screws are available upon request.

WARNING

- Adjust the screws very unevenly between them;
 - Manually adjust the actuator shaft to bring the valve to complete closure;
 - apply pressure to the chamber of the springs;
- each of these actions may result in loss of contact between the piston and spring container (held in place by the screw if adjusted for a partial stroke) and affect proper operation of the actuator.

Adjustment table

This table represents the mean angular variation α for each complete screw adjustment revolution β .
 For each 1° variation for $\alpha 1$ the adjustment screw is to be rotated as $\beta 1$.

ACTUATOR SIZE	ADJUSTMENT SCREW ROTATION ANGLE	SHAFT VARIATION ANGLE AFTER ADJUSTMENT	ADJUSTMENT SCREW ROTATION ANGLE	SHAFT VARIATION ANGLE AFTER ADJUSTMENT
	β	α	$\beta 1$	$\alpha 1$
DA15	360°	3°34'	120°	1°
DA30	360°	2°54'	120°	1°
SR15	360°	3°7'	120°	1°
DA60	360°	2°18'	144°	1°
SR30	360°	2°26'	144°	1°
DA120	360°	1°55'	180°	1°
SR60	360°	2°	180°	1°
DA180	360°	2°14'	144°	1°
SR90	360°	2°14'	144°	1°
DA240	360°	2°	180°	1°
SR120	360°	1°54'	180°	1°
DA360	360°	1°45'	216°	1°
SR180	360°	1°40'	216°	1°
DA480	360°	1°49'	180°	1°
SR240	360°	1°54'	180°	1°
DA720	360°	1°37'	230°	1°
SR360	360°	1°45'	205°	1°
DA960	360°	1°28'	270°	1°
SR480	360°	1°57'	180°	1°
DAN1440	360°	1°31'	220°	1°
SRN720	360°	1°40'	200°	1°
DAN1920	360°	1°28'	270°	1°
SRN960	360°	1°33'	216°	1°

* The table data refers only to the standard stroke adjustment (10°).
 For longer adjustment screws please contact our Technical Sales Department.

6) MATERIALS AND THEIR DURABILITY

The OMAL S.p.A. actuators are designed to have minimal maintenance-free resistance, in accordance with EN 15714-3, as shown in the following table

Nominal torque (a) Nm	Minimum Cycles intended for pistons and cylinder (b)	Cycle minimum time, 0-90° in seconds "s"
≤125	500 000 (c)	3
≤1 000	500 000	5
≤2 000	250 000	8
≤8 000	100 000	15
≤32 000	25 000	20
≤63 000	10 000	30
≤125 000	5 000	45
≤250 000	2 500	60

a) Based on EN ISO 5211.

b) One cycle consists of nominal 90° angular travel in both directions (i.e. 90° to open + 90° to close). For angular travel other than 90°, the endurance shall be agreed between the purchaser and the manufacturer/supplier.

c) For thermoplastic actuators the minimum number of cycles shall be 250 000.

Note: Values based on a load of at least 60% of the stroke torque at 0,55 MPa \cong 5,5 bar supply and according to the test procedure described in attachment A of the EN 15714-3 standard.

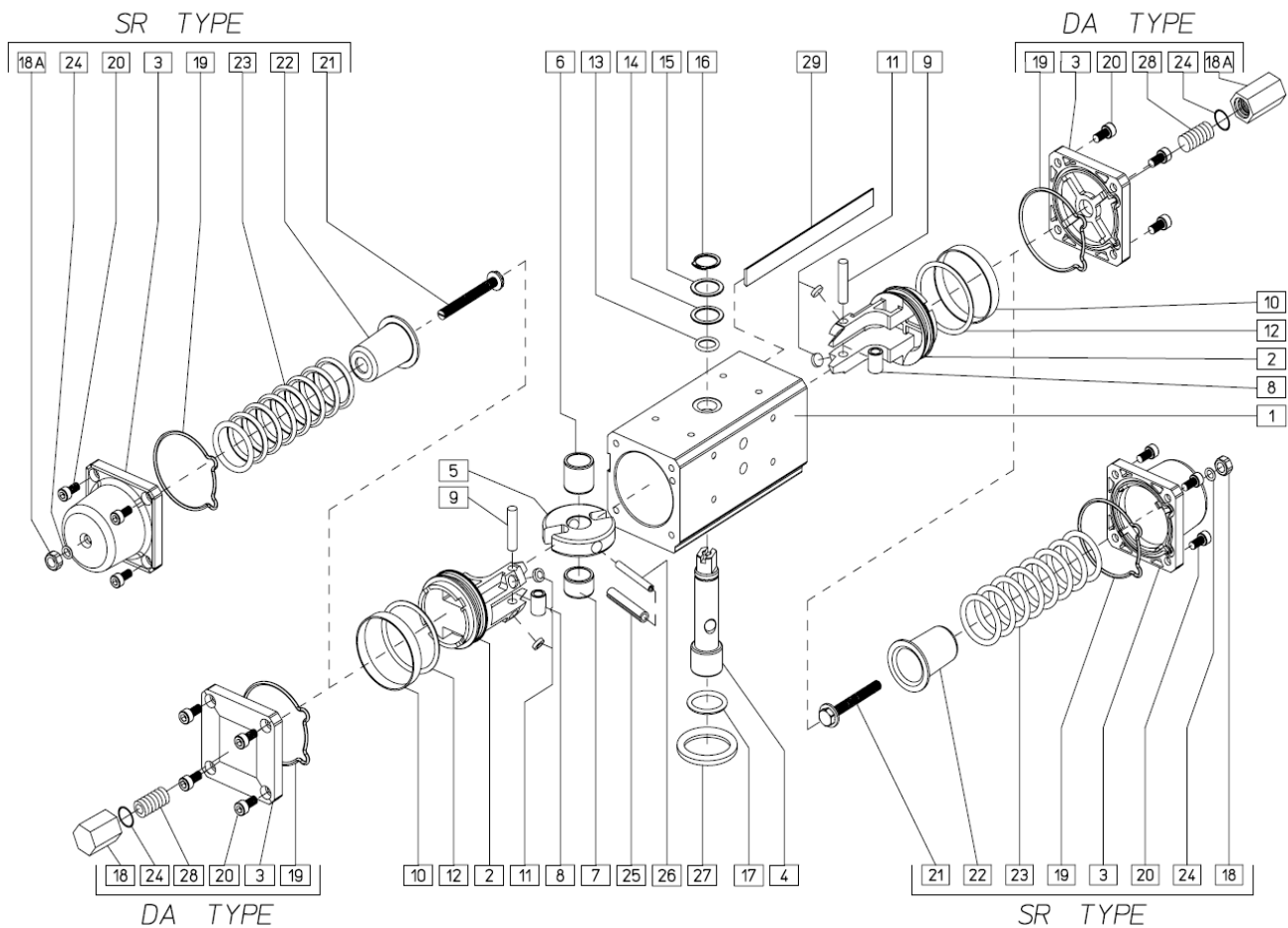
LIST OF COMPONENTS DOUBLE ACTING AND SPRING RETURN ALUMINUM ACTUATOR

POS	Particular
1	Cylinder
2	Piston
3	Cap
4	Shaft
5	Scotch yoke
6	Shaft Bearing
7	Shaft Bearing
8	Bearing
9	Stud
10*	Piston seal ring
11*	Support disk
12*	Piston O-ring
13*	Upper shaft O-ring
14	External support ring

* Parts included in the spare parts kit

POS	Particular
15	Washer
16	Seeger
17*	Lower shaft O-ring
18	Nut
19*	O-ring cap
20	Screw
21	Spring pre-load screw
22	Spring cap
23	Spring
24*	O-ring
25	External elastic pin
26	Internal elastic pin
27	Centering ring
28	Adjustment screw

LIST OF COMPONENTS SPRING RETURN AND DOUBLE ACTING ACTUATOR WITH HANDWHEEL

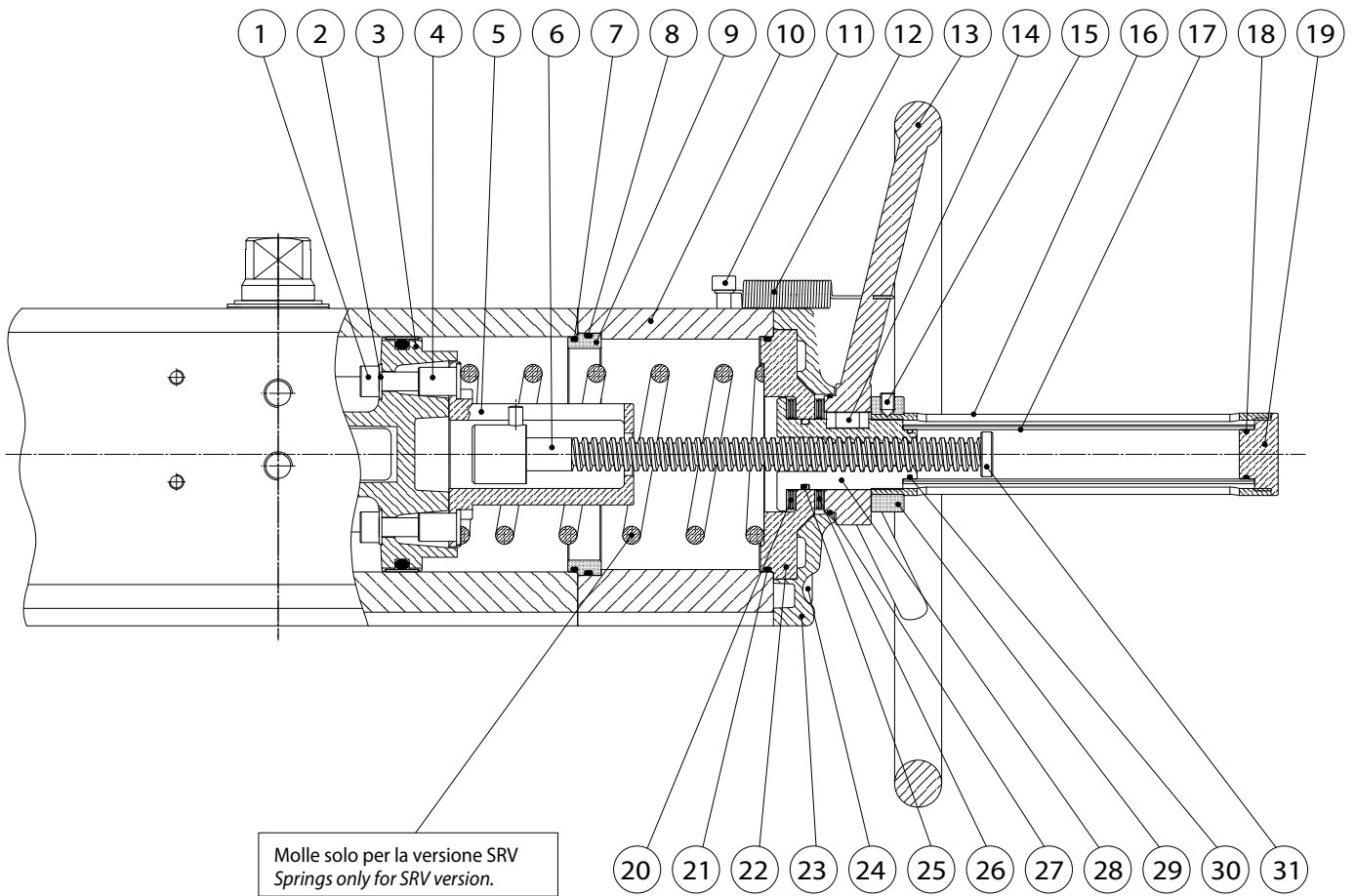

POS	Particolare
1	Screw
2	Gasket
3	Piston (modified)
4	Threaded bushing (only for DAV480-SRV240)
5	Special spring cap
6	Maneuver Screw
7	O-Ring
8	O-Ring
9	Centering ring
10	Shim cylinder
11	Screw
12	Spring (SRV versions only)
13	Handwheel
14	Flap
15	Screw
16	Protection pipe

POS	Particolare
17	Transparent pipe
18	O-Ring
19	Protection cap
20	Roller bearing
21	O-Ring
22	Flange
23	Cap(modified)
24	Screw
25	O-Ring
26	Roller bearing
27	O-Ring
28	Maneuver Nut
29	Protection ring
30	O-Ring
31	Indicator

LIST of COMPONENTS PRECISION CASTING SPRING RETURN AND DOUBLE ACTING ACTUATOR

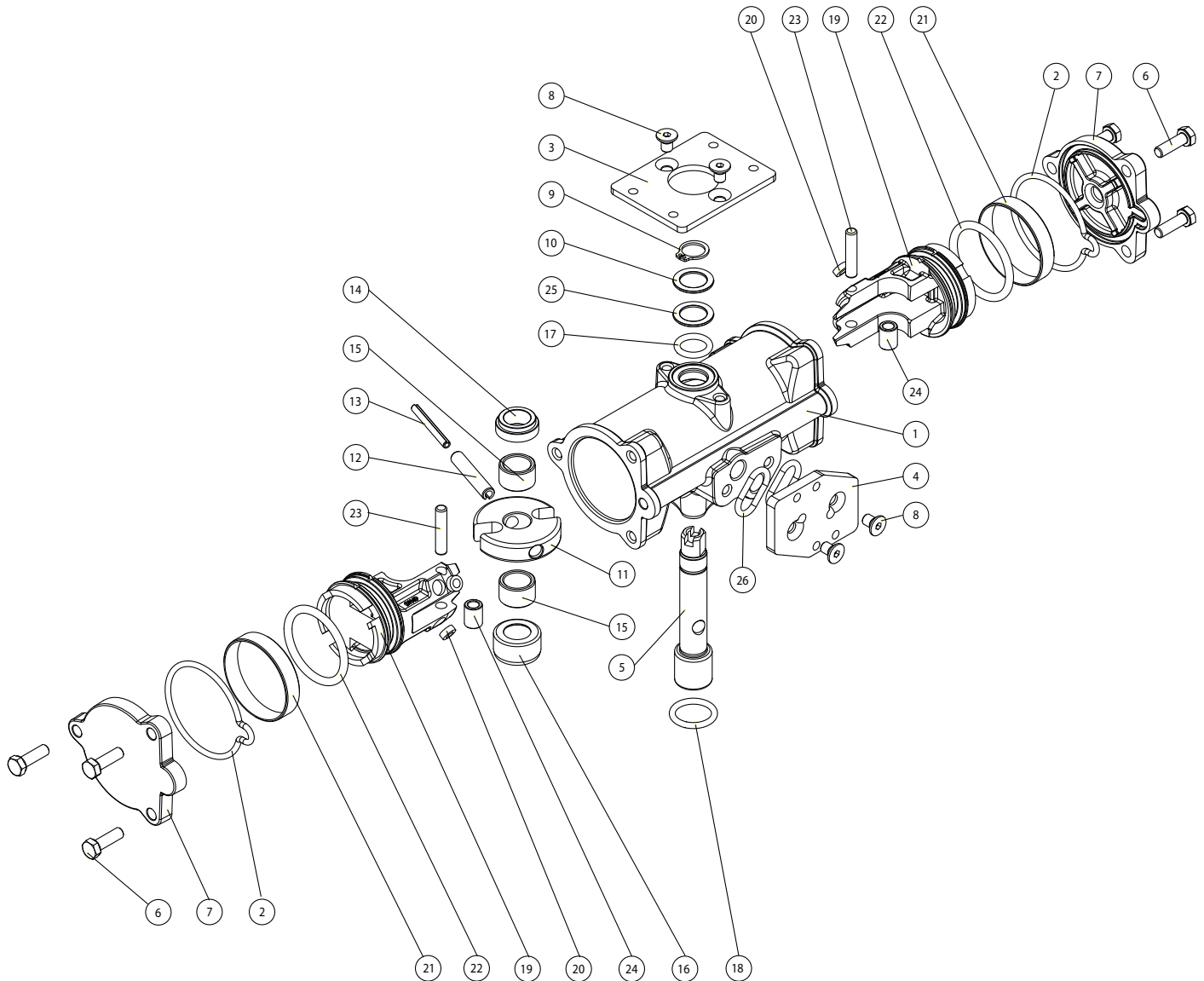

Pos	Particular
1	Cylinder
2	O-ring Cap
3	VDI/VDE 3845 Socket
4	NAMUR Socket
5	Shaft
6	Screws
7	Cap
8	Screws
9	Seeger
10	Shimming Washer
11	Scotch yoke
12	External elastic pin
13	Internal elastic pin
14	Upper supper ring
15	Shaft bearing
16	Shaft bearing/support
17	Shaft upper O-ring

Pos	Particular
18	Shaft lower O-ring
19	Piston
20	Support disk
21	Sealing ring
22	Piston O-ring
23	Stud
24	Steel bush
25	External support ring
26	O-ring (optional)
27	Spring pre-load screws
28	Spring cap
29	Spring
30	Adjustment O-ring
31	Locknut

OMAL S.p.A.

 Headquarters: Via Ponte Nuovo, 11 - 25050 Rodengo Saiano (BS) Italy · Production Site: Via Brognolo, 12 - 25050 Passirano (BS) Italy
 Ph. +39 030 8900145 · Fax +39 030 8900423 · info@omal.it · www.omal.com

**LIST of COMPONENTS STAINELSS STEEL
 SPRING RETURN AND DOUBLE ACTING ACTUATOR FROM BAR**

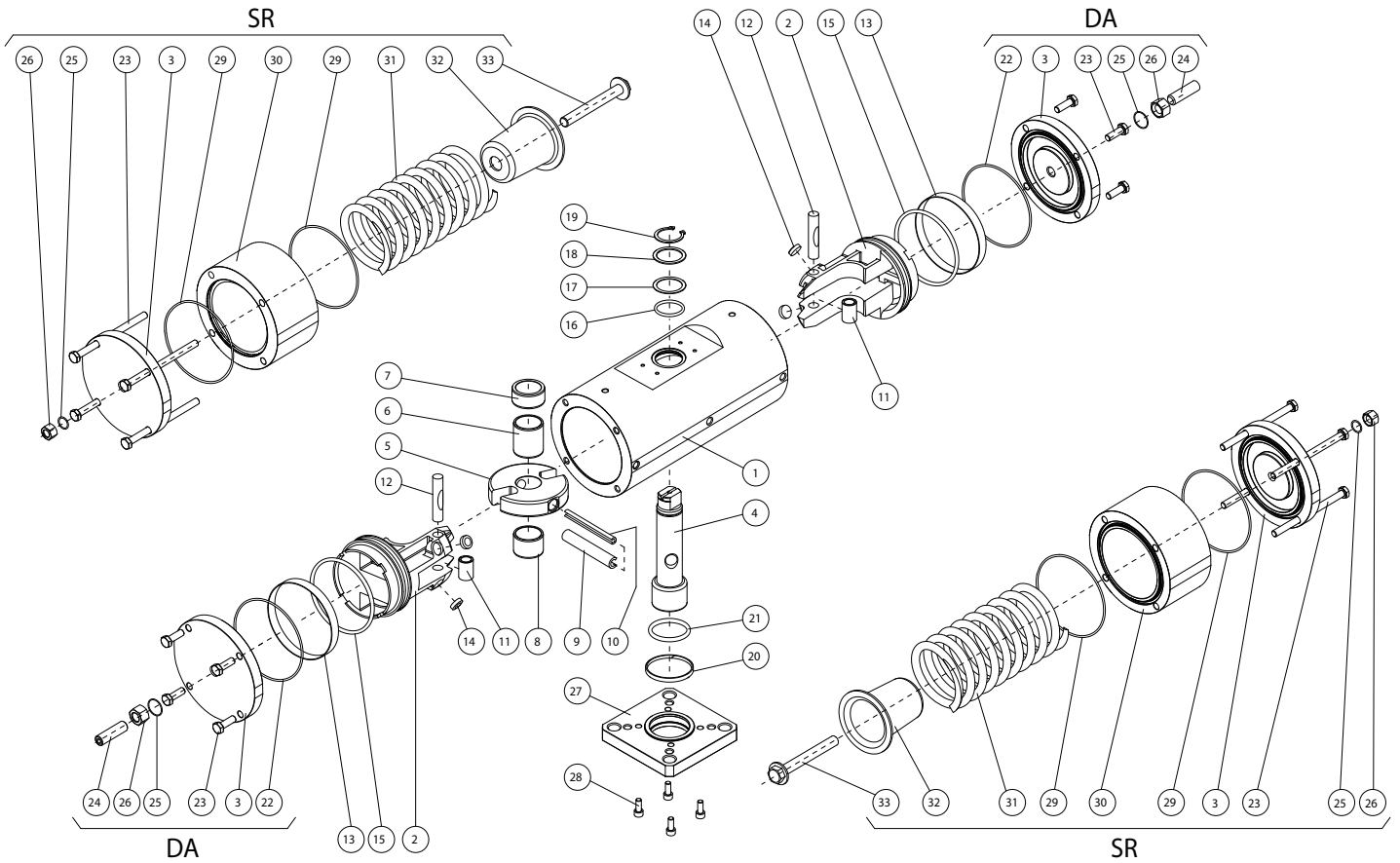

Pos	Particular
1	Cylinder
2	Piston
3	Cap
4	Shaft
5	Scotch yoke
6	Shaft bearing /support
7	Upper support ring
8	Shaft bearing
9	External elastic pin
10	Internal elastic pin
11	Steel bush
12	Stud
13	Sealing ring
14	Support disk
15	Piston O-ring
16	Shaft upper O-ring
17	External support ring

Pos	Particular
18	Shimming Washer
19	Seeger
20	Lower support clamp
21	Shaft lower O-ring
22	O-ring Cap DA
23	Screws
24	Adjustment screw
25	adjustment O-ring
26	Locknut
27	Fixing flange
28	Screws
29	O-ring Cap SR
30	Cylinder shim
31	Spring
32	Spring cap
33	Spring pre-load screws

LIST of COMPONENTS TWO STAGE PNEUMATIC ACTUATOR

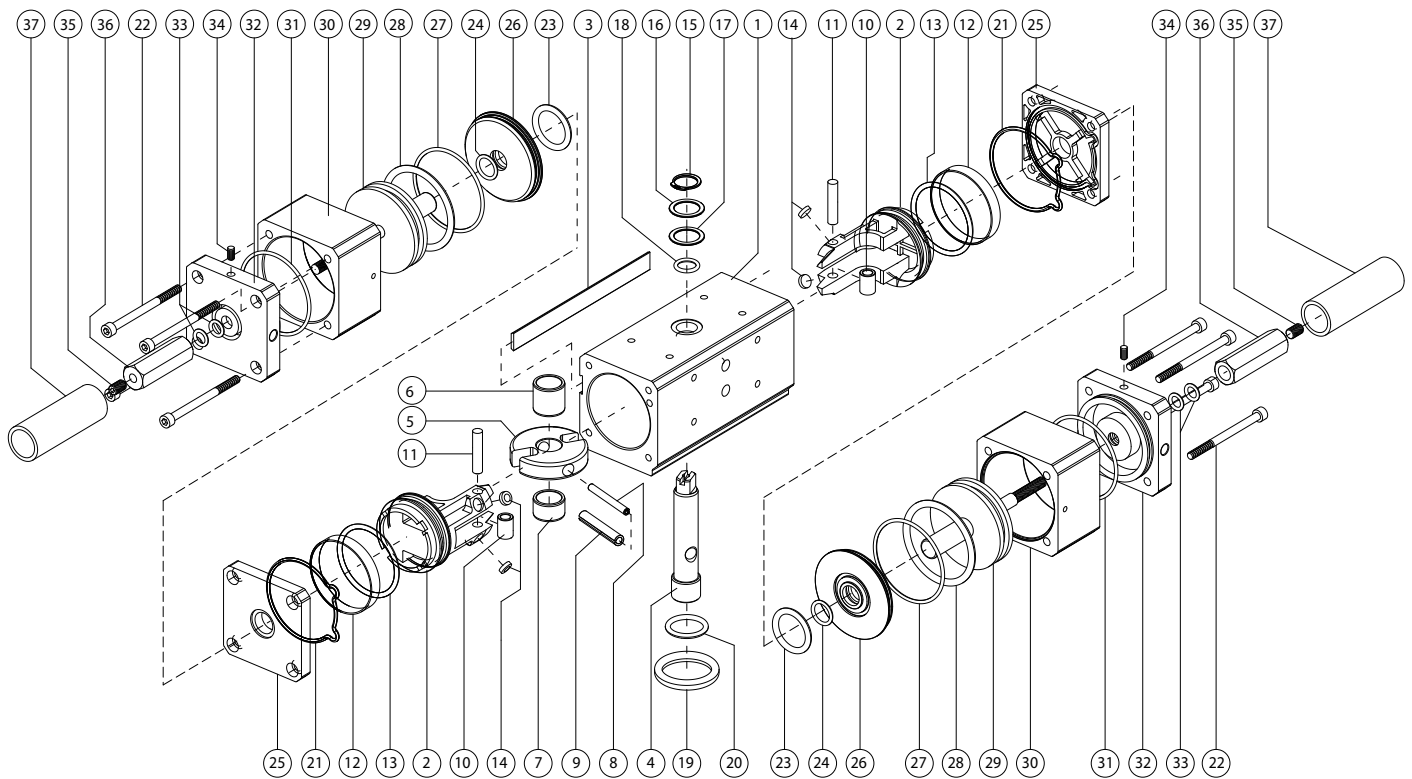

Pos	Particular
1	Cylinder
2	Piston
3	Rod
4	Shaft
5	Scotch yoke
6	Shaft bearing
7	Shaft bearing
8	Internal elastic pin
9	External elastic pin
10	Steel bush
11	Stud
12	Sealing ring
13	Piston O-ring
14	Support disk
15	Seeger
16	Shimming Washer
17	External support ring
18	Shaft upper O-ring
19	Centering ring

Pos	Particular
20	Shaft lower O-ring
21	Cap seal O-ring
22	Screws
23	Ring nut side O-ring
24	Internal ring nut O-ring
25	Intermediate cap
26	Ring nut
27	External ring nut O-ring
28	Auxiliary piston O-ring
29	Auxiliary Piston
30	Auxiliary cylinder
31	O-ring end cap
32	End cap
33	Internal O-ring end cap
34	Grub screw
35	Grub screw
36	Adjustment Locknut
37	Protection

7) MAINTENANCE

The OMAL SpA actuator, when installed and used properly, does not require maintenance, under normal use, as it's provided with sufficient lubrication for standard duration.

Send the actuator directly to OMAL S.p.A. for inspection or extraordinary maintenance

If the cap or piston seals need to be replaced, OMAL SpA can supply a kit containing spare parts.

WARNING: The seals must be replaced by qualified personnel and with the appropriate tools

OMAL S.p.A. declines all responsibility for products that are repaired by third parties

Replacing the seals

a) Disassembly

The dismantling operations must be carried out when the actuator is disconnected from all electrical and pneumatic connections and removed from the valve.

Verify that the actuator is not pressurized and in the spring return versions, that the springs are completely in the rest position. Check that ports 2 and 4 are free.

Use appropriate tools only.

a. Unscrew the screws (ref.20) crosswise to remove the caps (ref.3), if the operation seems to be difficult, this means that the actuator is still pressurized or that the springs are not at rest. Check and depressurize the actuator or release the springs before continuing. Remove the caps (rif.03 and 20) and replace the seal (ref.19).

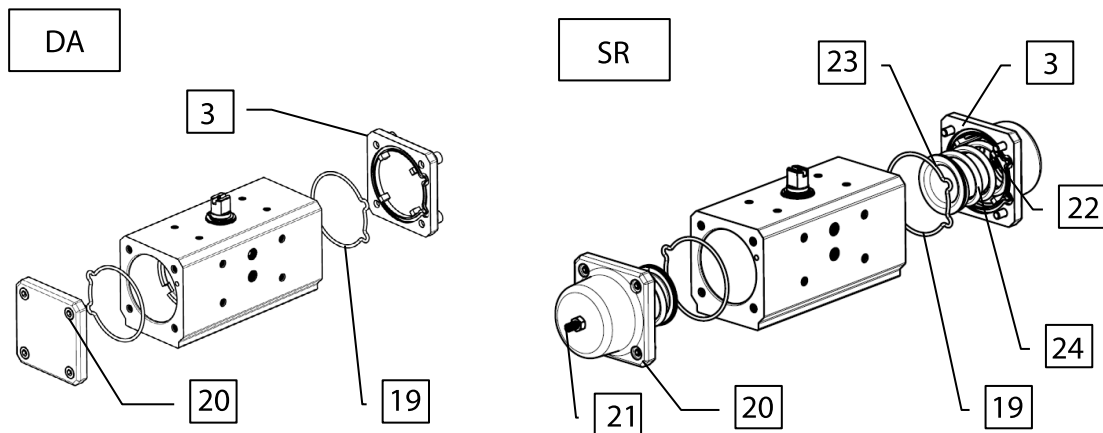

Attention.

The spring cap (ref.3+18+24+19+23+22+21) is a safety device: **DO NOT** loosen the screw (ref.21) to remove the spring from its seat. This operation must be carried by qualified personnel only.

b. Keep the actuator locked with a clamp while turning the stem until the pistons (ref 2) are not released from the grooved seat on the shaft (ref.5), then remove the piston from the cylinder (ref 1). Do not use compressed air to remove the piston from the cylinder for it may cause injuries.

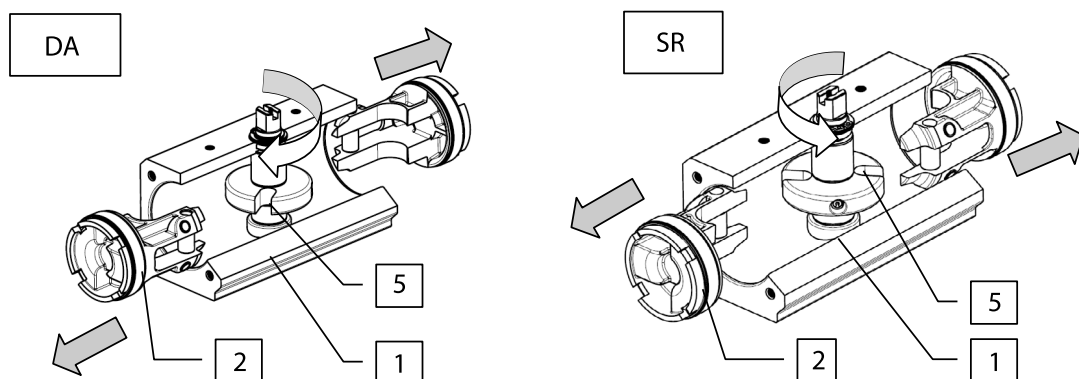

c. The piston band (ref.10), the O-ring (ref.12) and the sliding pads (ref.11) are to be checked before replacing them. Do not use sharp tools to remove the bands, the O-ring or the pads from the piston because they may get scratched or damaged.

d. The components that have been removed must be carefully cleaned and checked before being greased and reassembled. If the seals are worn out, they need to be replaced with new parts from the kit.

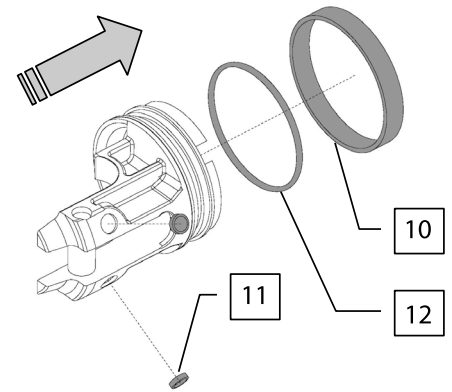

b) Assembly

a. The O-ring (ref.12) and band (ref.10) must be mounted on the piston by using a conical tool that allows to easily slip them into their seat (see drawing) without damaging them.

b. Push the pads (ref.11) in P.T.F.E. into their seat on the piston.

c. Grease the piston (ref.2) on the replaced parts (ref.10+11+12), and the sliding bush (ref.8)

d. Grease the cylinder inner surface (ref 1).

e. Position the shaft (ref.5) so that its grooves are in the right position to receive the pistons so that it could have the correct rotation direction.

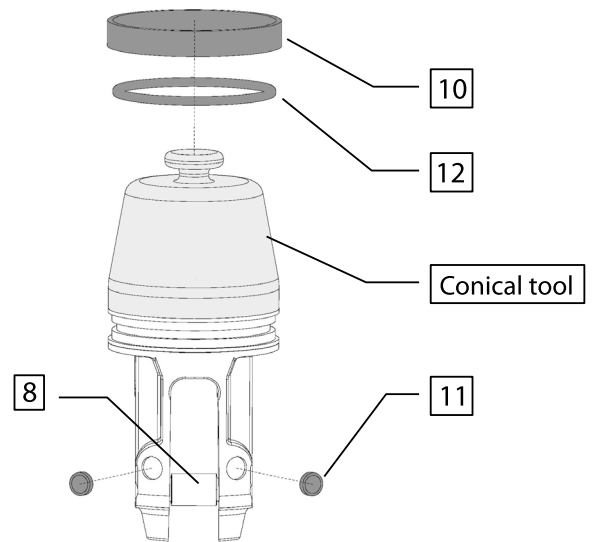

f. . Insert the pistons (ref.2) in the grooves (ref.5) and push them, simultaneously, inside the cylinder (ref.1). The OMAL S.p.A. Scotch yoke system will prevent the misalignment of the pistons.

g. Replace the seals (ref.19) in the seats on the caps (ref.3) and grease them. Fasten the caps to the body by tightening the screws crosswise (ref.20).

h. Apply, to the screws, the tightening torque indicated in paragraph 5 of page 13.

While holding the actuator in a clamp, rotate the shaft to check the rotation direction and its correct movement.

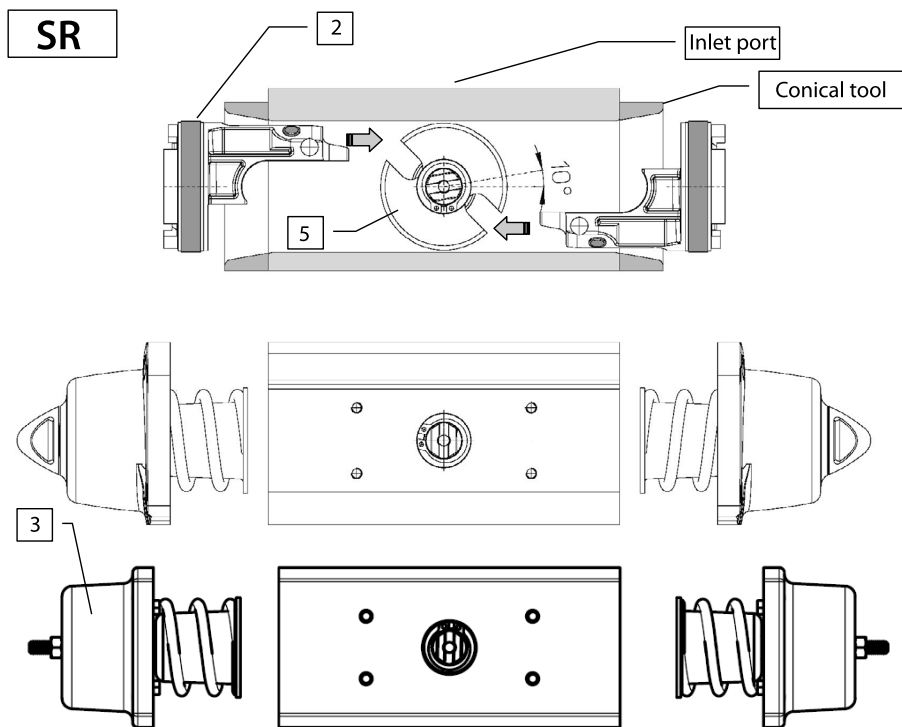
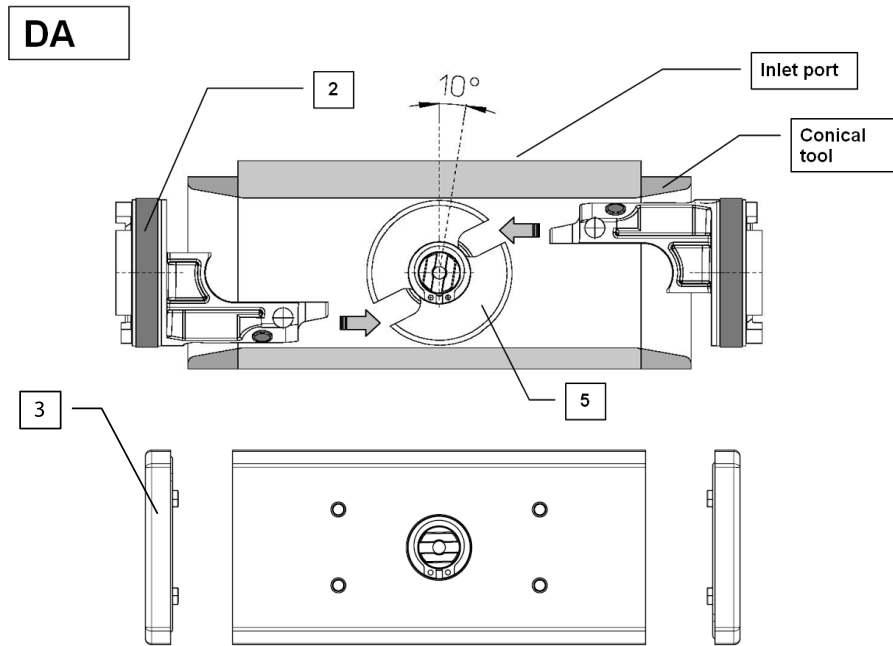

8) SPECIAL VERSION

OMAL S.p.A. produces and supplies also special versions of its actuators, for applications in low temperature conditions (-50°C) and high temperature (+150°C), for the use in explosive atmosphere environments (II 2 GD TX X) and for other specific uses.

a. External protection

All versions can be supplied with a different external protection according to the environmental conditions of the system (for the choice, consult the OMAL S.p.A. catalogue or contact the commercial department).

b. Stainless steel version

For plants of the food industry or chemical sector, OMAL SpA produces a stainless steel version. The body and all external parts are made of stainless steel AISI316.

c. Normally open spring return version

The normally open spring return version is required in the cases where if there should be a pressure or power failure, the valve must absolutely remain open. In this version the pistons are inserted in the cylinder like the ones for the double acting version, the strength of the springs makes the actuator normally open.

ATTENTION

The performance of the normally open Spring Return version, compared to the normally closed Spring Return one, are very different due to the production differences. For the sizing and choice please contact the OMAL S.p.A. technical department.

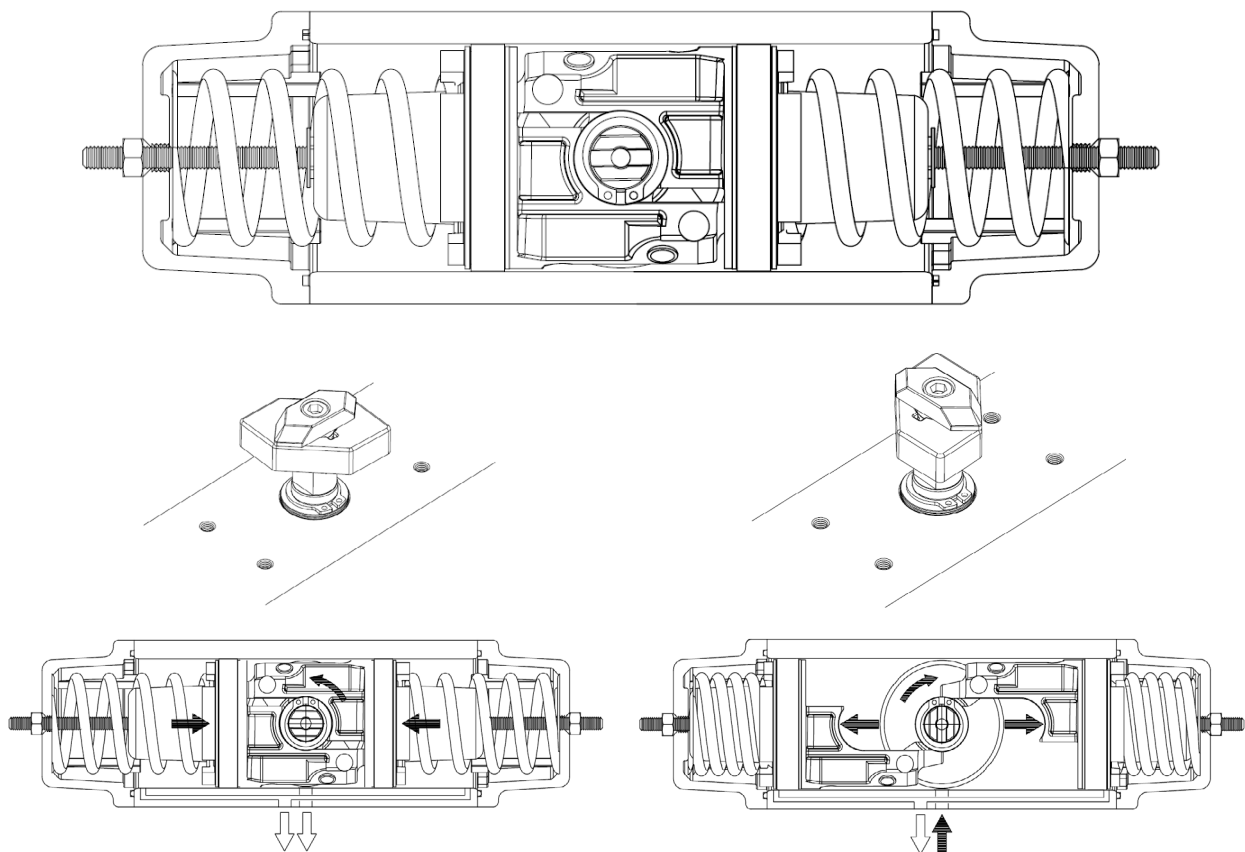

OMAL S.p.A.

Headquarters: Via Ponte Nuovo, 11 - 25050 Rodengo Saiano (BS) Italy · Production Site: Via Brognolo, 12 - 25050 Passirano (BS) Italy
 Ph. +39 030 8900145 · Fax +39 030 8900423 · info@omal.it · www.omal.com

d. Double Acting Special Version

This DA Double Acting version with rotating pistons and extra long regulating screws, limits the valve and actuator stroke in the open position, with a 45% limit over the total ability.

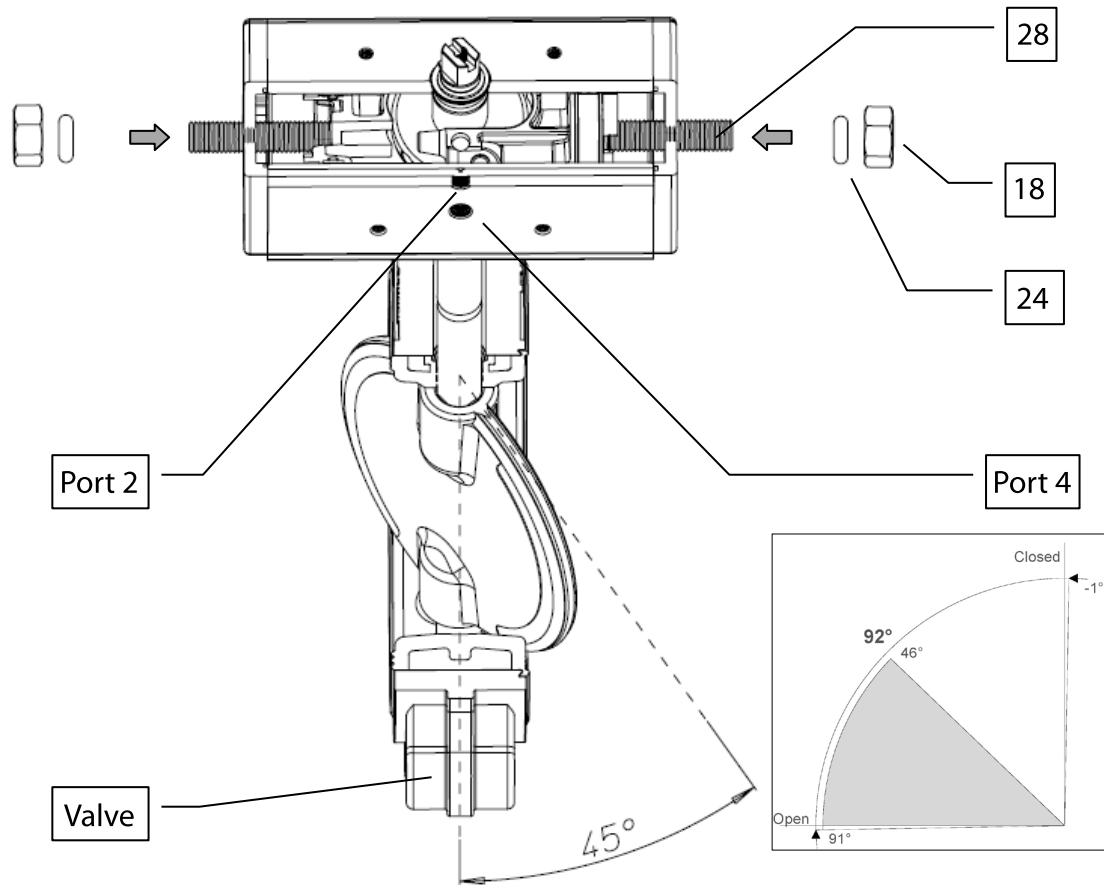

9) STORAGE

The OMAL S.p.A. actuators are properly packaged for protection during the dispatch, but they could still get damaged accidentally during transportation. Before storing them verify that they have not been damaged during the transportation. Keep actuators in the package when storing.

Choose clean sites for storage, not excessively humid and with temperatures between -10 and $+60^{\circ}\text{C}$. If the products are to be stored for long periods of time, it is best not to remove them from their protective packaging.

The actuators have two air ports, plugged with plastic caps, in order to avoid that liquids or other may enter through during the storage.

If the items will be in storage for a long period of time before installation, it is recommended to maneuver them periodically in order to avoid that the seals get damaged.

Store the actuators indoors to protect them from dust and moisture.

10) TROUBLESHOOTING

POTENTIAL EFFECT OF FAILURE	POTENTIAL CAUSE OF FAILURE	SOLUTION
Loss or reduction of the supplied torque	Lack of supply	Verify that the actuator has been connected to the pneumatic line correctly
	Air supply not enough to produce the required torque	Verify that the supply pressure value corresponds to the functioning requirements (See actuator data plate).
	Air leakage from the seals	Verify that the screws are completely tightened
Leaks from the stem upper or lower seals	Stem O-ring seal damaged	Contact OMAL S.p.A. for repair
	Damages on the body	
	Shaft damaged	
Leakage from cylinder caps	Seals damaged	Replace the seals (see "Maintenance" chapter)
Leakage from the ports after maneuver	Piston sealing damaged	Replace the piston seals (see "Maintenance" chapter)
	Cylinder body damaged	Contact OMAL S.p.A. for repair
Insufficient rotation angle	Increase of valve maneuver torque	Verify the valve release torque and possibly replace with a new one
	Air supply not enough to produce the required torque	Increase the air supply
	Mechanical stop (if there) not duly adjusted	Adjust the stops by increasing the stroke
	Wrong connection between the actuator and the valve stem	Check the connection elements between the valve and the actuator

11) DISPOSAL OF PRODUCTS AT THE END OF THEIR LIFE CYCLE

The OMAL products are designed so that when they are at the end of their life cycle they can be completely disassembled, separating the different materials for the proper disposal and/or recovery. All materials have been selected in order to ensure minimal environmental impact, health and safety of personnel during their installation and maintenance, provided that, during use, they are not contaminated by hazardous substances.

The personnel in charge of the product disposal/recovery, must be qualified and equipped with appropriate personal protective equipment (PPE), according to the product size and the type of service for which the device was intended. The management of waste generated during the installation, maintenance or due to the product disposal, is governed by the rules in force in the country where the product is installed, in any case, the following are general guidelines:

- The metal components (aluminum/steel) can be restored as raw material;
- Seals/sealing elements (PTFE, PEEK, NBR, EPDM, FKM ...), as contaminated by fluids from other materials and lubrication, must be disposed of.
- The packaging materials that come with the product, should be transferred to the differentiated collection system available in the country.

12) STATEMENT OF CONFORMITY

The OMAL S.p.A. actuators have been designed, manufactured and tested to meet the requirements of the following European standards and are marked, where provided, with the relative CE conformity marking:

- 2006/42/EC Directive "Machinery";
- 2014/34/EU Directive "Equipment and protective systems intended for use in potentially explosive atmospheres" (ATEX).
- Regulation (EC) No 1907/2006 and successive Concerning the Registration, Evaluation, Authorization and Restriction of Chemicals (REACH)