

WHEN PERFORMANCE MATTERS MOST™

Clamp On 120v Circuit Breaker Lockout

TDS No. LOTO-14
Effective Date: 20-Nov-2012

Description:

- Design**
- Extremely versatile device, works on a wide range of single-pole breakers
 - Made of rugged polypropylene and impact modified nylon
 - Use thumbscrew to clamp lockout securely onto switch tongue, then pull cover over thumbscrew and lock in place to prevent clamp from being loosened
 - Blade design provides tighter grip with less torque on thumbscrew
 - Accepts lock shackles up to 9/32" in diameter, and comes with detachable cleats to expand the range of applicable breakers



- Material**
- Outer Housing: Polypropylene
 - Color: Red (PMS 1805C)
 - Steel Clamp: molded Glass-filled Nylon
 - Steel Screw: molded Glass-filled Nylon thumbscrew.
 - Color: Black
 - UL Rating: UL 94 – HB (Plastic Components Only)

Chemical	°C	Chemical	°C
Acetone	25	Petroleum	25
Acetone	60	Turpentine oil	25
Chlorine, chlorine water	25	Turpentine substitute (white spirit)	25
Fuel, engine: Gasoline (normal & premium grade)	85	Trichloroethane 1,1,1	45
Lubrication oil: gear oil	< 120	Lubricating oil: HD engine oils, hydraulic oils, transformer oils	< 120
Fuel, engine: M15 mixture (15% methanol)	70	Water (including seawater)	25
Methanol	25	Water (including seawater), chlorinated (<0,5 mg/l)	80

- Temperature Range**
- Polypropylene Housing: : -20° to 80°C (0° to 175°F)
 - Glass-filled Nylon: -20° to 120°C (0° to 250°F)

Chemical Resistance
All approved chemicals listed are based on the manufactures specified chemical resistance chart for plastic material only.

Dimensions

"A"	-	2.205" [56mm]
"B"	-	0.950" [24.1mm]
"C"	-	0.650" [16.5mm]
"D"	-	0.445" [11.3mm]
"E"	-	1.000" [25.4mm]
"F"	-	0.281" [7.1mm]

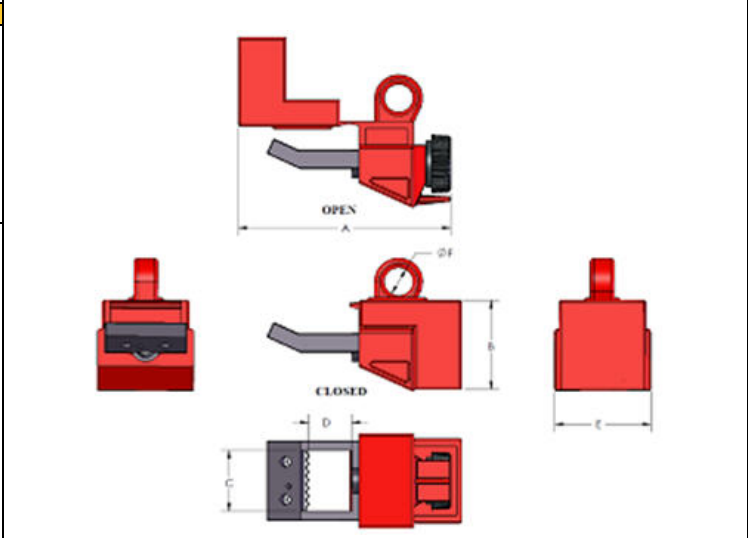

Warranty
Note: All values shown are averages and should not be used for specification purposes. Test data and test results contained in this document are for general information only and shall not be relied upon by Brady customers for designs and specifications, or be relied on as meeting specified performance criteria. Customers desiring to develop specifications or performance criteria for specific product applications should

contact Brady for further information.

Product compliance information is based upon information provided by suppliers of the raw materials used by Brady to manufacture this product or based on results of testing using recognized analytical methods performed by a third party, independent laboratory. As such, Brady makes no independent representations or warranties expressed or implied, and assumes no liability in connection with the use of this information.

Circuit Breaker Cross Reference Guide

Circuit Breaker Manufacture	Breaker Type	# of Poles	Circuit Breaker Manufacture	Breaker Type	# of Poles	Circuit Breaker Manufacture	Breaker Type	# of Poles	Circuit Breaker Manufacture	Breaker Type	# of Poles
American Ckt. Bkr.	NEF	3	Cutler Hammer	QHCW	1	General Electric	TQD	2-3	Square D	KA	2-3
American Switch	C	1	Cutler Hammer	QHCX	1	General Electric	TQL-A	1	Square D	KAL	2-3
Bryant	BR	1	Cutler Hammer	QHPW	1	General Electric	TQL-S	1	Square D	KC	2-3
Challenger	C	1	Cutler Hammer	QHPX	1	Heinemann	LB	1	Square D	KCL	2-3
Challenger	LM	1	Cutler Hammer	QPGF	1	Heinemann	LF	1	Square D	KH	2-3
Challenger	NEJ	1-2	Cutler Hammer	QPGFEP	1	Heinemann	LJ	1	Square D	KHL	3
Cutler Hammer	BA	1	Cutler Hammer	QPHGF	1	Lemag	SD62	1	Square D	KI	2-3
Cutler Hammer	BAB	1	Cutler Hammer	QPHGFEP	2	Merlin Gerin	CE104N	3	Square D	KIL	2-3
Cutler Hammer	BD	1	Cutler Hammer	QPHW	1	Siemens ITE	BL	1	Square D	Q1B	2-3
Cutler Hammer	BR	1	Fed. Pacific Elec	BAB	1	Siemens ITE	BLH	1	Square D	Q1L	2-3
Cutler Hammer	BRH	1	Fed. Pacific Elec	NB	1	Siemens ITE	BQ	1	Square D	Q2	2-3
Cutler Hammer	CC	3	Fed. Pacific Elec	NB GFI	1	Siemens ITE	BQCH	1-3	Square D	Q2H	2-3
Cutler Hammer	CH	1	Fed. Pacific Elec	NE/NEF	1-3	Siemens ITE	BQD	1-3	Square D	Q2L	2-3
Cutler Hammer	CHH	3	Fed. Pacific Elec	NEJ	1-3	Siemens ITE	BQH	1	Square D	Q2MT	2-3
Cutler Hammer	CHB	1	Fed. Pacific Elec	NFJ	1-3	Siemens ITE	CEDE6	2-3	Square D	QO	2-3
Cutler Hammer	CHP	1	Fed. Pacific Elec	NP-single	1	Siemens ITE	CQD	1-3	Square D	QOB	2-3
Cutler Hammer	CL	1	Frank Adams	P	1	Siemens ITE	E2	1-3	Square D	QOB-VH	1
Cutler Hammer	CSR	1	FUJI Electric	EA53B	3	Siemens ITE	E4	1-3	Square D	QOM1-VH	2
Cutler Hammer	E125B	1-4	FUJI Electric	EA203B	3	Siemens ITE	ED	1-3	Square D	QOM2-VH	2
Cutler Hammer	E125E	1-4	FUJI Electric	BU-ESB	3	Siemens ITE	ED4	1-3	Square D	QO-SWN	2-3
Cutler Hammer	E125H	1-4	FUJI Electric	BU-ESA	3	Siemens ITE	ED6	1-3	Square D	QOU	2-3
Cutler Hammer	E125S	1-4	FUJI Electric	BU-F5B	3	Siemens ITE	ED6-ETI	3	Square D	QO-VH	2-3
Cutler Hammer	ED	2-4	General Electric	HQC	3	Siemens ITE	EE3	3	Thomas & Betts	F Frame	1-3
Cutler Hammer	EDC	2-4	General Electric	SED	2-3	Siemens ITE	EH3	3	Toshiba	E225B	3
Cutler Hammer	EDH	2-4	General Electric	SEH	2-3	Siemens ITE	ET	3	Westinghouse	BA	1-3
Cutler Hammer	EFH	1-4	General Electric	SEL	2-3	Siemens ITE	FJ2-B	2-3	Westinghouse	BAB	1-3
Cutler Hammer	EGB	1-4	General Electric	SEP	2-3	Siemens ITE	GF	1	Westinghouse	BR	1-3
Cutler Hammer	EGE	1-4	General Electric	SFH	2-3	Siemens ITE	HBL	1	Westinghouse	CA	
Cutler Hammer	EGS	1-4	General Electric	SFL	2-3	Siemens ITE	HBO	1	Westinghouse	EB	1-3
Cutler Hammer	EHC	1-4	General Electric	SFP	2-3	Siemens ITE	HE4	1-3	Westinghouse	ED	
Cutler Hammer	EHD	1-4	General Electric	TB	2	Siemens ITE	HED4	1-3	Westinghouse	EH	1-3
Cutler Hammer	FB	2-3	General Electric	TBC	2	Siemens ITE	HED6	2-3	Westinghouse	EBH	1-3
Cutler Hammer	FC	1-4	General Electric	TE	1-3	Siemens ITE	HHED6	2-3	Westinghouse	EHD	1-3
Cutler Hammer	FD	1-4	General Electric	TEB	1-3	Siemens ITE	HQJ2-H	3	Westinghouse	FA	3
Cutler Hammer	FDB	2-4	General Electric	TED	1-3	Siemens ITE	HQP	1	Westinghouse	FB	2-3
Cutler Hammer	FDC	2-4	General Electric	TEF	1-3	Siemens ITE	HQPP	1	Westinghouse	FD	1-4
Cutler Hammer	FS	2-3	General Electric	TEL	3	Siemens ITE	QJ2	2-3	Westinghouse	FDB	2-4
Cutler Hammer	GB	1-3	General Electric	TEML	3	Siemens ITE	QJ2-H	2-3	Westinghouse	FDC	2-4
Cutler Hammer	GC	1-3	General Electric	TEY	1-3	Siemens ITE	QJH2	2-3	Westinghouse	GB	1-3
Cutler Hammer	GD	1-3	General Electric	TF	1-3	Siemens ITE	QP	1	Westinghouse	GBH	1-3
Cutler Hammer	GDB	1-3	General Electric	TFC	3	Siemens ITE	QP1	1	Westinghouse	GHB	1-3
Cutler Hammer	GHB	1-3	General Electric	THED	1-3	Siemens ITE	QPH	1	Westinghouse	HBAW	1
Cutler Hammer	GHBGFEP	1	General Electric	THEF	1-3	Siemens ITE	QPP	1	Westinghouse	HBAW	1
Cutler Hammer	GHC	1-3	General Electric	THHQB-A	1	Siemens ITE	QPPH	1	Westinghouse	HCA	3
Cutler Hammer	GHCGFEP	1	General Electric	THHQB-S	1	Siemens ITE	3VF3	3	Westinghouse	HFB	1-3
Cutler Hammer	HBAW	1	General Electric	THHQC-A	1	Square D	EDB	1-3	Westinghouse	HFD	1-4
Cutler Hammer	HBAW	1	General Electric	THHQC-S	1	Square D	EQB	1-3	Westinghouse	HMCP	
Cutler Hammer	HFD	1-4	General Electric	THHQL-A	1	Square D	EH4	1-3	Westinghouse	HONP	3
Cutler Hammer	HGHB	1	General Electric	THHQL-S	1	Square D	EHB	1-3	Westinghouse	HQP	1
Cutler Hammer	HGHC	1	General Electric	THLC1	3	Square D	EJ6	1-3	Westinghouse	MCPO	3
Cutler Hammer	HMCP	2-3	General Electric	THQB-A	1	Square D	FA	1-3	Westinghouse	P	3
Cutler Hammer	HQP	1	General Electric	THQB-S	1	Square D	FAL	1-3	Westinghouse	QBHW	1
Cutler Hammer	QBGF	1	General Electric	THQC-A	1	Square D	FC	3	Westinghouse	QC	1
Cutler Hammer	QBGFEP	1	General Electric	THQC-S	1	Square D	FCL	2-3	Westinghouse	QCHQ	1
Cutler Hammer	QBHG	1	General Electric	THQD	2-3	Square D	FDA		Westinghouse	QHCW	1
Cutler Hammer	QBHGFEF	1	General Electric	THQL-A	1	Square D	FH	1-3	Westinghouse	QHCX	1
Cutler Hammer	QBHW	1	General Electric	THQL-S	1	Square D	FHL	1-3	Westinghouse	QHPW	1
Cutler Hammer	QC	1	General Electric	TJC	2-3	Square D	FHL-DC	3	Westinghouse	QPHW	1
Cutler Hammer	QCD	1	General Electric	TKC	3	Square D	FHP	3	Westinghouse	Quicktag P	
Cutler Hammer	QCGF	1	General Electric	TQB-A	1	Square D	FI	3	Westinghouse	RE	
Cutler Hammer	QCGFEF	1	General Electric	TQB-S	1	Square D	FIL	3	Westinghouse	WPHX	1
Cutler Hammer	QCHGF	1	General Electric	TQC-A	1	Square D	FY	1	Zinsco	HQB	6
Cutler Hammer	QCHGFEP	1	General Electric	TQC-S	1	Square D	GJL	3	Zinsco	QB	1
Cutler Hammer	QCHW	1									

Details:

MSDS Information

1. HAZARDS IDENTIFICATION

This product is NOT DANGEROUS and contains no hazardous ingredients.

2. FIRST AID MEASURES HEALTH INFORMATION PROTECTION

Eye Contact:	Not applicable, product is inert
Ingestion:	Not applicable, first aid is not normally required.
Inhalation:	Not applicable
Skin Contact:	Not applicable, product is inert, except if product is melted use gloves. For hot melted product, immerse in or flush affected area with water to dissipate heat, then obtain medical attention.
Exposure Limits:	None
Threshold Limits	None
Personal Protection:	None (ambient conditions)
NPCA-HMIS Rating:	Health: 0; Flammability: 1; Reactivity: 0
NFPA-704 Rating:	Health: 0; Flammability: 1; Reactivity: 0

3. FIRE-FIGHTING MEASURES

<ul style="list-style-type: none">Be cautious of hot melted NylonIsolate product from fireExtinguish fire with water spray	<ul style="list-style-type: none">Use water spray to cool fire, exposed surfaces, and to protect personnelRespiratory and eye protection is required for fire fighting personnelDecomposition products under fire conditions: Oxygen-lean conditions may cause monoxide and irritating smoke
--	--

4. ACCIDENTAL RELEASE MEASURES

Land	Recover material and place in suitable container for reuse or for disposal in conformance with local regulations.
Water	Recover material and place in suitable container for reuse or for disposal in conformance with local regulations.

5. HANDLING AND STORAGE

5.1 Handling	5.2 Storage
No precautions noted-see local regulation if needed	Storage pressure: Atmospheric
	Storage temperature: Ambient, no direct sunlight

6. EXPOSURE CONTROLS PERSONAL PROTECTION

6.1 Exposure limit values	6.2 Exposure Controls
None	6.2.1 Occupational Exposure Controls
	6.2.1.1 Respiratory Protection: Not applicable
	6.2.1.2 Hand Protection: Not applicable
	6.2.1.3 Eye Protection: Not applicable
	6.2.1.4 Skin Protection: Not applicable
	6.2.2 Environmental Exposure Controls: No data available

7. PHYSICAL AND CHEMICAL PROPERTIES

General Information	
Other Information	

8. STABILITY AND REACTIVITY

8.1 Conditions to Avoid
Higher Temperatures and direct sunlight (chemical resistance is excellent)
Highly stable, but temperatures over 480 F may cause degradation
8.2 Materials to Avoid
No data available
8.3 Hazardous Decomposition Products
Under fire and oxygen-lean conditions may cause monoxide and irritating smoke

9. ECOLOGICAL INFORMATION

9.1 Ecotoxicity	No data available
9.2 Mobility	No data available
9.3 Persistence and Degradability	No data available
9.4 Bioaccumulative Potential	No data available
9.5 Other Adverse Effects	No data available

10. DISPOSAL CONSIDERATIONS

None of the materials in this product are Recyclable, dispose of all materials in accordance with an applicable federal, state, and local law.
--

11. TRANSPORT INFORMATION

No data available

12. REGULATORY INFORMATION

This product has been tested and validated to the Regulatory Requirements listed below:	
<ul style="list-style-type: none">OSHA 29 CFR 1910.147 @ (4)(ii)(A)(1)(c)(X)(ii)(C)(1)	<ul style="list-style-type: none">ANSI Standard Z244

13. OTHER INFORMATION

No data available

Trademarks:

Note: All values shown are averages and should not be used for specification purposes.

Test data and test results contained in this document are for general information only and shall not be relied upon by Brady customers for designs and specifications, or be relied on as meeting specified performance criteria. Customers desiring to develop specifications or performance criteria for specific product applications should contact Brady for further information.

Product compliance information is based upon information provided by suppliers of the raw materials used by Brady to manufacture this product or based on results of testing using recognized analytical methods performed by a third party, independent laboratory. As such, Brady makes no independent representations or warranties, express or implied, and assumes no liability in connection with the use of this information.

WARRANTY

Brady products are sold with the understanding that the buyers will test them in actual use and determine for themselves their adaptability to their intended uses. Brady warrants to the buyers that its products are free from defects in material and workmanship, but limits its obligation under this warranty to replacement of the product shown to Brady's satisfaction to have been defective at the time Brady sold it. This warranty does not extend to any persons obtaining the product from the buyers. This warranty is in lieu of any other warranty, express or implied, including, but not limited to, any implied warranty of merchantability or fitness for a particular purpose, and of any other obligations or liability on Brady's part. Under no circumstances will Brady be liable for any loss, damage, expense, or consequential damages of any kind arising in connection with the use, or inability to use, Brady's products.

Copyright 2015 Brady Worldwide, Inc. | All Rights Reserved
Material may not be reproduced or distributed in any form without written permission.