

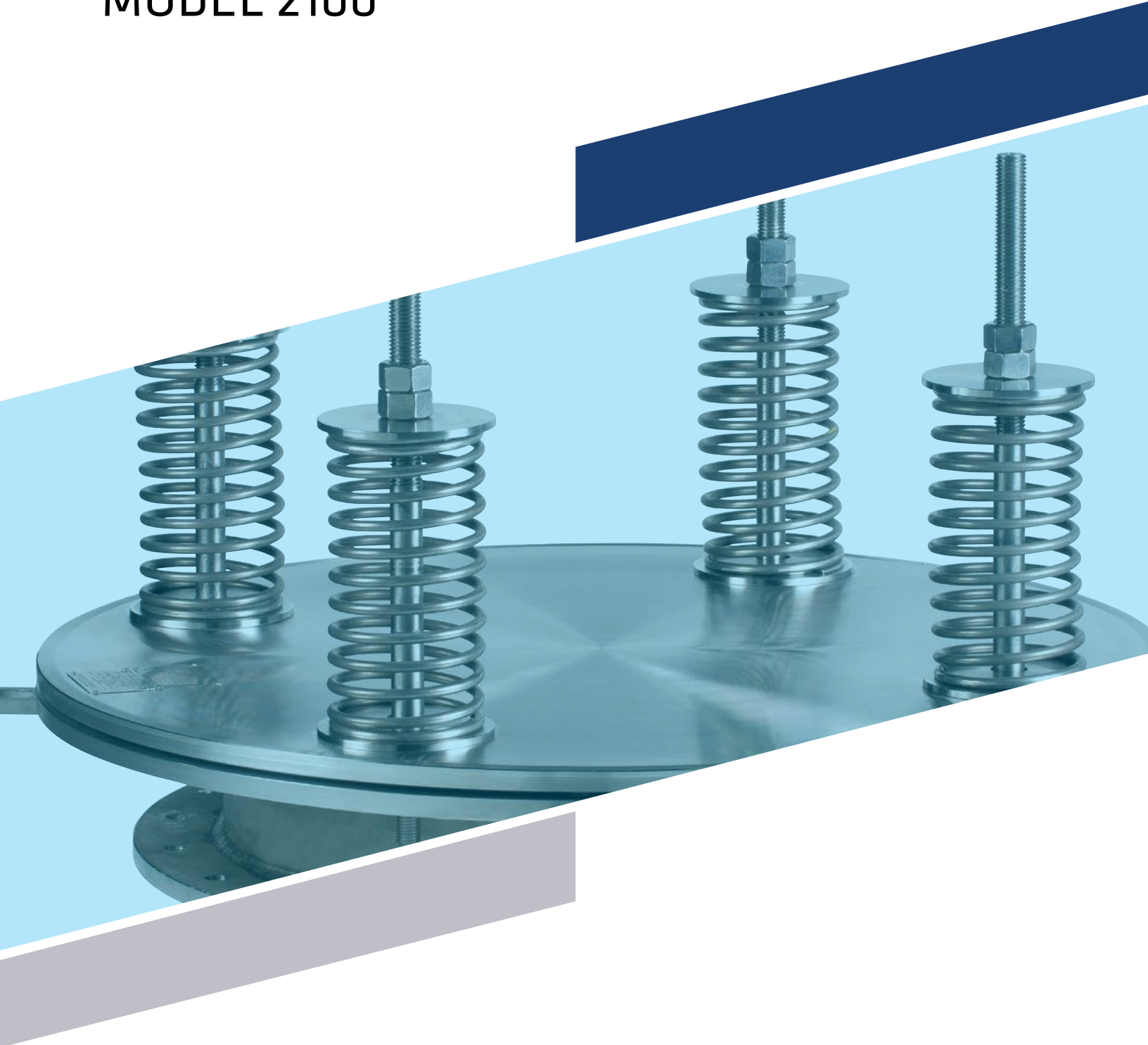

EMERGENCY RELIEF VENT

MODEL 2100



MODEL 2100

The Groth Model 2100 is designed to provide emergency relief capacity beyond that furnished by the normal operating pressure relief valve on the tank. The valve protects the tank against rupture or explosion that could result from excessive internal pressure. Model 2100 relieves, then reseats when the overpressure event has been dissipated.

Technical Details

- Sizes: 16" (DN 400) , 20" (DN 500) and 24" (DN 600)
- Pressure Settings: 1 to 15 psig (68.9 mbarg to 1.03 barg)
- Materials: Carbon Steel, Stainless Steel, special materials upon request
- ATEX Approved

Features

- Easy access manway combined with emergency relief
- Independently adjustable springs keep the valve tightly sealed
- FKM seating ensures a tight seal

Options

- Steam Jacket
- Buna-N, Fluoropolymer, FKM
- ANSI 150# and API 650 drilling classes
- Vacuum port available on some configurations, please consult factory



SPECIFICATIONS

Size* Flange In (mm)	Minimum Setting Pressure Spring Loaded psig (mbar)	Maximum Setting Pressure Spring Loaded psig (mbar)	A Width In (mm)	B Height† In (mm)	Approx. Ship Weight Lbs (kg)	
					At min. set	At max. set
16 (406)	1 (69)	15 (1.03)	36.75 (933)	23 (584)	310 (141)	490 (223)
20 (508)	1 (69)	15 (1.03)	36.75 (933)	23 (584)	335 (152)	500 (227)
24 (610)	1 (69)	15 (1.03)	40.75 (1035)	27 (686)	420 (190)	670 (304)

* 150# ANSI, drilling compatibility, or API 650 drilled flange option

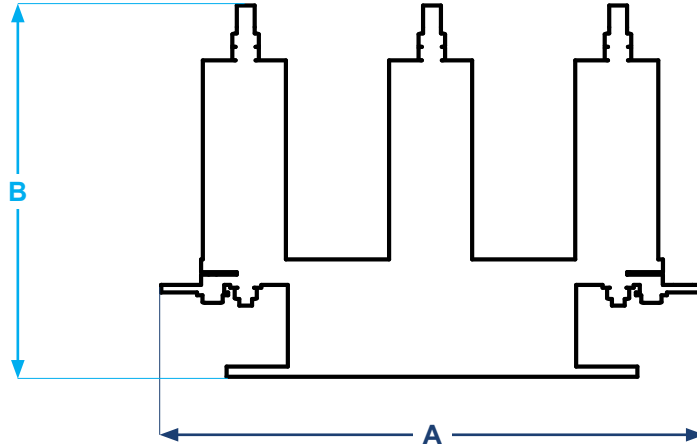

PRESSURE RELIEF CAPACITY

Air Flow Capacity at 100% Overpressure (Double Set Pressure)
1000 Standard Cubic Feet per Hour at 60° F

Set Pressure (P _s)	Size In (mm)		
	16 (406)	20 (508)	24 (610)
psig			
1.00	609	952	1371
2.00	857	1340	1930
3.00	1045	1633	2352
4.00	1201	1877	2704
5.00	1337	2089	3009
6.00	1458	2278	3282
7.00	1568	2450	3529
8.00	1669	2608	3757
9.00	1763	2755	3969
10.0	1851	2893	4167
11.0	1934	3022	4353
12.0	2012	3145	4530
13.0	2087	3261	4697
14.0	2158	3372	4857
15.0	2226	3478	5010

Flow Capacity Calculation

Flow capacity values listed above are based on full open valves at 100% overpressure. Read the flow capacity at 100% overpressure directly from the table above. Use linear interpolation if the set pressure is not listed. If the allowable overpressure is less than 100%, modify the flow capacity using the appropriate "C" factor from the table. If allowable overpressure is more than 100%, consult your Groth Representative.

Calculate the percentage overpressure by the following formula. Note that all pressures are gauge pressure expressed in the same units of measure.

P_f = Flowing pressure

P_s = Set pressure

$$\% \text{ OP} = [(P_f - P_s) / P_s] \times 100$$

Calculate flow capacity at less than 100% overpressure according to the following example.

Example Flow Capacity Calculation

20" Model 2100

4 psig Set Pressure [P_s]

7 psig Flowing Pressure [P_f]

1. Read flow capacity at set pressure from table Flow = 1,877,000 SCFH

2. Calculate overpressure

$$\% \text{ OP} = [(7 - 4) / 4] \times 100 = 75\%$$

3. Read "C" factor from table

$$"C" = 0.83$$

4. Calculate flow capacity

$$\text{Flow} = 0.83 \times 1,877,000 = 1,557,910 \text{ SCFH}$$

"C" Factor Table

%OP	0	1	2	3	4	5	6	7	8	9
10	*** Consult Factory***									
20	0.27	0.29	0.30	0.32	0.33	0.35	0.36	0.38	0.39	0.40
30	0.42	0.43	0.44	0.45	0.47	0.48	0.49	0.50	0.51	0.52
40	0.53	0.54	0.55	0.56	0.57	0.58	0.59	0.60	0.61	0.62
50	0.63	0.64	0.65	0.66	0.67	0.67	0.68	0.69	0.70	0.71
60	0.72	0.72	0.73	0.74	0.75	0.76	0.76	0.77	0.78	0.79
70	0.80	0.80	0.81	0.82	0.82	0.83	0.84	0.85	0.85	0.86
80	0.87	0.87	0.88	0.89	0.90	0.90	0.91	0.92	0.92	0.93
90	0.94	0.94	0.95	0.96	0.96	0.97	0.97	0.98	0.99	1.00

Example to find "C" factor from table:

Read "C" factor for 75% overpressure at intersection of row 70 and column 5

"C" factor at 75% OP = 0.83

PRESSURE RELIEF CAPACITY

Air Flow Capacity at 100% Overpressure (Double Set Pressure)
1000 Normal Cubic Meters per Hour at 0°C

Set Pressure (P _s)	Size In (mm)		
	16" (406 mm)	20" (508 mm)	24" (610 mm)
barg			
0.07	17.8	27.8	39.9
0.10	21.2	33.1	47.6
0.15	25.8	40.4	58.1
0.20	29.7	46.5	66.8
0.25	33.1	51.8	74.5
0.30	36.2	56.6	81.3
0.35	38.9	60.9	87.5
0.40	41.5	64.9	93.3
0.45	43.9	68.6	98.6
0.50	46.1	72.1	104
0.55	48.2	75.4	108
0.60	50.2	78.5	113
0.70	53.9	84.3	121
0.80	57.3	89.6	129
0.90	60.5	94.6	136
1.00	63.4	99.2	143

Flow Capacity Calculation

Flow capacity values listed above are based on full open valves at 100% overpressure. Read the flow capacity at 100% overpressure directly from the table above. Use linear interpolation if the set pressure is not listed. If the allowable overpressure is less than 100%, modify the flow capacity using the appropriate "C" factor from the table. If allowable overpressure is more than 100%, consult your Groth Representative.

Calculate the percentage overpressure by the following formula. Note that all pressures are gauge pressure expressed in the same units of measure.

$$\begin{aligned} P_f &= \text{Flowing pressure} \\ P_s &= \text{Set pressure} \\ \% \text{ OP} &= [(P_f - P_s) / P_s] \times 100 \end{aligned}$$

Calculate flow capacity at less than 100% overpressure according to the following example.

Example Flow Capacity Calculation

20" Model 2100

0.4 barg Set Pressure [P_s]

0.7 barg Flowing Pressure [P_f]

1. Read flow capacity at set pressure from table Flow = 64,900 NCMH
2. Calculate overpressure % OP = [(0.7 - 0.4) / 0.4] x 100 = 75%
3. Read "C" factor from table "C" = 0.83
4. Calculate flow capacity Flow = 0.83 x 64,900 = 53,867 NCMH

"C" Factor Table										
%OP	0	1	2	3	4	5	6	7	8	9
10	*** Consult Factory***									
20	0.27	0.29	0.30	0.32	0.33	0.35	0.36	0.38	0.39	0.40
30	0.42	0.43	0.44	0.45	0.47	0.48	0.49	0.50	0.51	0.52
40	0.53	0.54	0.55	0.56	0.57	0.58	0.59	0.60	0.61	0.62
50	0.63	0.64	0.65	0.66	0.67	0.67	0.68	0.69	0.70	0.71
60	0.72	0.72	0.73	0.74	0.75	0.76	0.76	0.77	0.78	0.79
70	0.80	0.80	0.81	0.82	0.82	0.83	0.84	0.85	0.85	0.86
80	0.87	0.87	0.88	0.89	0.90	0.90	0.91	0.92	0.92	0.93
90	0.94	0.94	0.95	0.96	0.96	0.97	0.97	0.98	0.99	1.00

Example to find "C" factor from table:

Read "C" factor for 75% overpressure at intersection of row 70 and column 5

"C" factor at 75% OP = 0.83

HOW TO ORDER

For easy ordering, select proper model numbers

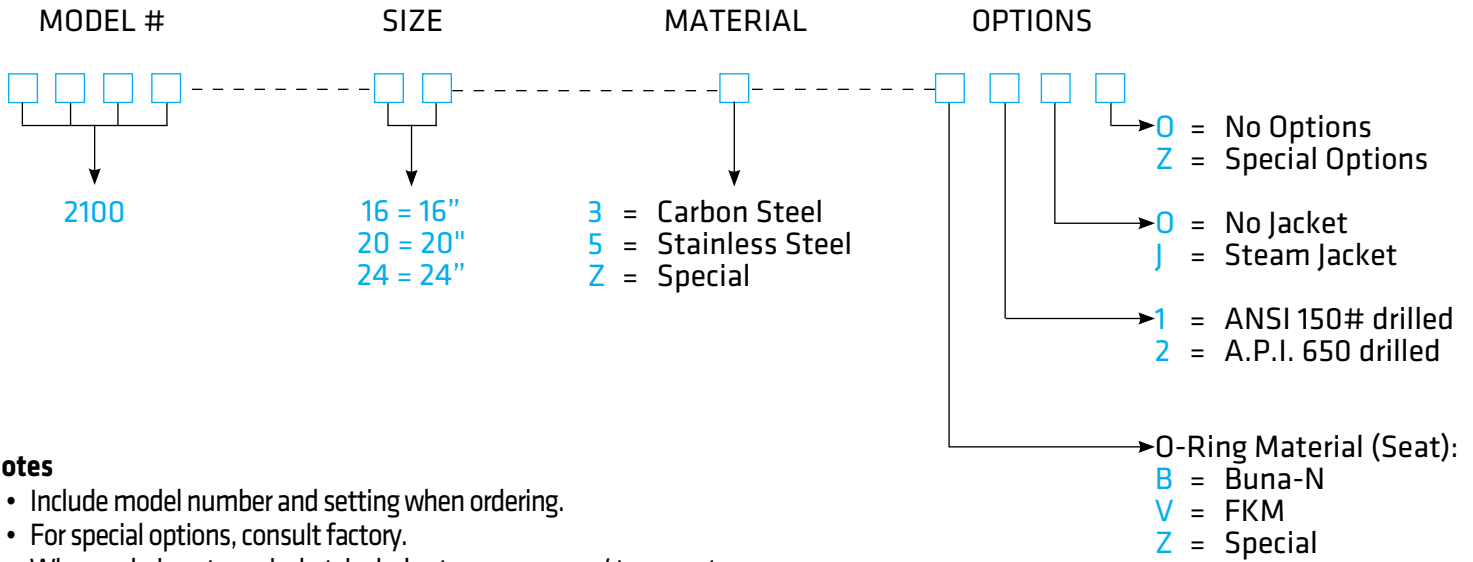

Notes

- Include model number and setting when ordering.
- For special options, consult factory.
- When ordering steam jacket, include steam pressure / temperature.
- * Seat material on carbon steel base is Stainless Steel weld overlay.
- ** Fluoropolymer O-Ring not available

Example

2 1 0 0 - 2 0 - 5 - V 1 J 0

Indicates a 20" Model 2000A with Stainless Steel Body, FKM Seat O-Ring, ANSI 150# drilled, Steam Jacket and no other options.

GROTH

CORPORATION





GROTHCORP.COM